

OPERATOR'S MANUAL  
AND  
SET-UP INSTRUCTIONS  
FOR THE

**WDL-2070**  
REAR-FOLD TRANSPORT  
CART & HARROW SECTIONS

VERSION: 10-12  
starting at serial number 16844

TO THE OWNER AND OPERATORS

Before assembling or operating this unit, READ THIS MANUAL THOROUGHLY. To obtain the best performance of the unit, familiarize yourself with each component and adjustment. Store this manual where it can be readily available for future reference. In the event that the harrow or any part of the unit should be sold, be sure that the new owner receives a copy of this manual for their reference.

1330 DALLAS STREET, P.O. BOX 100  
SAUK CITY, WISCONSIN 53583  
PHONE: (608) 643-3321  
TOLL FREE: (800) 627-8569 FAX: (608) 643-3976

## TABLE OF CONTENTS

INTRODUCTION .....	3
LIMITED WARRANTY .....	3
SAFETY .....	4
CONTACT INFORMATION.....	5
LIGHTING AND MARKING.....	6
SAFETY SIGN CARE .....	7
TIRE SAFETY.....	7 - 8
BEFORE OPERATION.....	7 - 8
DURING OPERATION .....	8 - 9
FOLLOWING OPERATION .....	9
HIGHWAY AND TRANSPORT OPERATIONS .....	9 - 10
PERFORMING MAINTENANCE .....	10
MAINTENANCE AND SERVICE SCHEDULE .....	11
OPERATING SUGGESTIONS.....	11
ASSEMBLY SUGGESTIONS .....	12
ASSEMBLY INSTRUCTIONS .....	13 - 34
FINAL ADJUSTMENTS .....	34
TROUBLESHOOTING.....	35
BOLT TORQUE SPECIFICATIONS .....	APPENDIX A
PARTS DIAGRAMS AND LISTS .....	APPENDIX B
LAYOUT DIAGRAMS.....	APPENDIX C
WARRANTY REGISTRATION FORM .....	LAST PAGE

## **INTRODUCTION**

Thank you for purchasing your new McFarlane transport cart and harrow sections. We know that you will get many years of dependable service from this modernly designed unit.

You may have had a particular application in mind when you purchased this unit. There are actually many uses for the McFarlane harrow including incorporation of herbicides and pesticides, leveling and smoothing tilled soil, and covering of broadcast seeds. Contact your dealer if you would like more information or have questions concerning these or other applications.

## **LIMITED WARRANTY**

### **FULL ONE - YEAR WARRANTY OF WDL-2000 Model**

If within one year from the date of purchase, this transport cart and/or its accompanying harrow sections fail due to defect in material or workmanship, McFarlane Mfg. Co., Inc. will repair it, free of charge.

Warranty service is available by simply contacting the nearest McFarlane dealership throughout the United States or Canada.

This warranty applies only while this product is used in the United States or Canada.

This warranty gives you specific legal rights, and you may have other rights which vary from state to state.

McFarlane Mfg. Co., Inc., Sauk City, Wisconsin 53583

## **SAFETY**

TAKE NOTE! THIS SAFETY ALERT SYMBOL FOUND THROUGHOUT THIS MANUAL IS USED TO CALL ATTENTION TO INSTRUCTIONS INVOLVING YOUR PERSONAL SAFETY AND THE SAFETY OF OTHERS. FAILURE TO FOLLOW THESE INSTRUCTIONS CAN RESULT IN INJURY OR DEATH.



THIS SYMBOL MEANS

- **ATTENTION!**
- **BECOME ALERT!**
- **YOUR SAFETY IS INVOLVED!**

### **SIGNAL WORDS:**

Note the use of the signal words DANGER, WARNING, and CAUTION with the safety messages. The appropriate signal word for each has been selected using the following guidelines:

**DANGER:** Indicates an imminently hazardous situation that, if not avoided, will result in death or serious injury.

**WARNING:** Indicates a potentially hazardous situation that, if not avoided, could result in death or serious injury.

**CAUTION:** Indicates a potentially hazardous situation that, if not avoided, may result in minor or moderate injury.

## CONTACT INFORMATION

If you have questions not answered in this manual, require additional copies, or the manual is damaged, please contact your local dealer or:

McFarlane Mfg. Co., Inc.  
1330 Dallas Street  
P.O. Box 100  
Sauk City, WI 53583

PHONE: (608) 643-3321  
TOLL FREE: (800) 627-8569  
FAX: (608) 643-3976



## SAFETY FIRST!



### Equipment Safety Guidelines

Safety of the operator is one of the main concerns in designing and developing a new piece of equipment. Designers and manufacturers build in as many safety features as possible. However, every year many accidents occur which could have been avoided by a few seconds of thought and a more careful approach to handling equipment. You, the operator, can avoid many accidents by observing the following precautions. To avoid personal injury, study the following precautions and insist that those working with you, or for you, follow them.

Replace any CAUTION, WARNING, DANGER, or instruction safety decal that is not readable or missing.

Do not attempt to operate this equipment under the influence of drugs or alcohol.

Review the safety instructions with all users annually.

This equipment is dangerous to children and persons unfamiliar with its operation. The operator should be a responsible adult familiar with farm machinery and trained in this equipment's operations. **Do not allow persons to operate or assemble this unit until they have read this manual and have developed a thorough understanding of the safety precautions and of how it works.**

To prevent injury, use a tractor equipped with a Roll Over Protective System (ROPS). Do not paint over, remove, or deface any safety signs or warning decals on your equipment. Observe all safety signs and practice the instructions on them.

Never exceed the limits of the transport cart or the harrows. If their ability to do a job, or to do so safely, is in question - **DO NOT TRY IT.**



### Lighting and Marking

It is the responsibility of the customer to know the lighting and marking requirements of the local highway authorities and to install and maintain the equipment to provide compliance with the regulations. Add extra lights when transporting at night or during periods of limited visibility.

Lighting kits are available from your dealer.



### Safety Sign Care

- Keep safety signs clean and legible at all times.
- Replace safety signs that are missing or have become illegible.
- Replacement parts that display a safety sign should display the same sign.
- Safety signs are available from your Distributor, Dealer Parts Department, or the factory.

How to Install Safety Signs:

- Be sure that the installation area is clean and dry.
- Decide on the exact position before you remove the backing paper.



### **Tire Safety**

- Failure to follow proper procedures when mounting a tire on a wheel or rim can produce an explosion which may result in serious injury or death.
- Do not attempt to mount tires unless you have the proper equipment and experience to do the job.
- Inflating or servicing tires can be dangerous. Whenever possible, trained personnel should be called to service and/or mount tires.
- Always order and install tires and wheels with appropriate capacity to meet or exceed the weight of the unit. Be sure to inflate tires to tire manufacturer's specifications
- Tires that are provided by the manufacturer are designed for speeds LESS THAN 20mph. Do Not exceed or tire failure will occur.



### **Remember:**

**Your best assurance against accidents is a careful and responsible operator. If there is any portion of this manual or function you do not understand, contact your local authorized dealer or the manufacturer.**



### **Before Operation:**

- Carefully study and understand this manual.
- Do not wear loose fitting clothing which may catch in moving parts.
- Always wear protective clothing and substantial shoes.
- It is recommended that suitable protective hearing and (eye protection) sight protectors be worn.
- Keep wheel lug nuts or bolts tightened.
- Assure that the tires are inflated evenly.
- Give the unit a visual inspection for any loose bolts, worn parts, or cracked welds, and make necessary repairs. Follow the maintenance safety instructions included in this manual.
- Before using the hydraulics on the cart, be sure all fittings and connections are tight.
- Be sure that there are no tools lying on the unit.
- Make sure that the area is clear of children, animals, and other obstacles before using.
- Don't hurry the learning process or take the unit for granted. Ease into it and become familiar with your new equipment. Practice operation of your new unit. Completely familiarize yourself and other operators with its operation before using.

- Securely attach to towing unit. Use a high strength, appropriately sized hitch pin with a mechanical retainer and attach safety chain.
- Do not allow anyone to stand between the tongue or hitch and the towing vehicle when backing up to the equipment.



### **During Operation:**

- **SAFETY CHAIN** - If equipment is going to be transported on a public highway, a safety chain should be obtained and installed. Always follow state and local regulations regarding a safety chain when towing farm equipment on a public highway. Be sure to check with local law enforcement agencies for your own particular regulations. Only a safety chain (not an elastic or nylon/plastic tow strap) should be used to retain the connection between the towing and towed machines in the event of separation of the primary attaching system.
- Install the safety chain by crossing the chains under the tongue and secure to the draw bar cage or hitch or bumper frame.
- Beware of bystanders, **particularly children!** Always look around to make sure that it is safe to start the engine of the towing vehicle or move the unit. This is particularly important with higher noise levels and quiet cabs, as you may not hear people shouting.
- **NO PASSENGERS ALLOWED** - Do not carry passengers anywhere on, or in, the tractor or equipment, except as required for operation.
- Keep hands and clothing clear of moving parts.
- Do not clean, lubricate, or adjust your equipment while it is moving.
- When altering operation, even periodically, set the tractor or towing vehicle brakes, shut off the engine, and **remove the ignition key.**
- Do not operate the hydraulic cylinders without the flow restrictors installed; the free falling harrow sections may cause serious injury.
- Pick the levellest possible route when transporting across fields. Avoid the edges of ditches or gullies and steep hillsides.
- Periodically clear the equipment of brush, twigs, or other materials to prevent buildup of dry combustible materials.
- Maneuver the tractor or towing vehicle at safe speeds.
- Avoid overhead wires or other obstacles. Contact with overhead lines could cause serious injury or death.
- Allow for unit length when making turns.
- Do not walk or work under raised wings unless securely positioned in wing rests.
- Keep all bystanders, pets, and livestock clear of the work area, particularly when raising or lowering harrow sections.
- Operate the towing vehicle from the operator's seat only.
- As a precaution, always recheck the hardware on equipment periodically. Correct all problems. Follow the maintenance safety procedures.





### **Following Operation:**

- When disconnecting, stop the tractor or towing vehicle, set the brakes, lock the wings together with the tie-bar (see Transformation Instructions), relieve hydraulic fluid pressure, shut off the engine and **remove the ignition keys**. Make sure all jack and support stands are in place before removing hitch pins.
- Store the unit in an area away from human activity on a hard level surface.
- Do not park equipment where it will be exposed to livestock for long periods of time. Damage and livestock injury could result.
- Do not permit children to play on or around the stored unit.



### **Highway and Transport Operations:**

- Make sure all transport lock provisions are in place and jack/parking stands are in their storage position before transporting the unit. Also, lock the wings together with the tie-bar (see Transformation Instructions).
- Adopt safe driving practices:
  - Keep the brake pedals latched together at all times. **NEVER USE INDEPENDENT BRAKING WITH MACHINE IN TOW AS LOSS OF CONTROL AND/OR UPSET OF UNIT MAY RESULT.**
  - Always drive at a safe speed relative to local conditions and ensure that your speed is low enough for an emergency stop to be safe and secure. Keep speed to a minimum.
  - Reduce speed prior to turns to avoid the risk of overturning.
  - Avoid sudden uphill turns on steep slopes.
  - Always keep the tractor or towing vehicle in gear to provide engine braking when going downhill. Do not coast.
  - Do not drink and drive!
- Comply with state and local laws governing highway safety and movement of farm machinery on public roads.
- Use approved accessory lighting flags and necessary warning devices to protect operators of other vehicles on the highway during daylight and nighttime transport. Various safety lights and devices are available from your dealer.
- The use of flashing amber lights is acceptable in most localities. However, some localities prohibit their use. Local laws should be checked for all highway lighting and marking requirements.
- When driving the tractor and equipment on the road or highway under 20 mph at night or driving during the day, use flashing amber warning lights and a slow moving vehicle (SMV) identification emblem.
- Remember, tires supplied by the manufacturer are designed to operate LESS THAN 20mph. Do Not exceed or tire failure will occur.

- Be a safe and courteous driver. Always yield to oncoming traffic in all situations, including narrow bridges, intersections, etc. Plan your route to avoid heavy traffic.
- Be observant of bridge loading ratings. Do not cross bridges rated lower than the gross weight at which you are operating.
- Watch for obstructions overhead and to the side while transporting.
- Always operate equipment in a position to provide maximum visibility at all times. Make allowances for increased length and weight of the equipment when making turns, stopping, etc.



### **Performing Maintenance:**

- Good maintenance is your responsibility. Poor maintenance is an invitation to trouble.
- Before working on this machine, stop the tractor or towing vehicle, set the brakes, lower into field position, relieve the hydraulic fluid pressure, shut off the engine and **remove the ignition keys**.
- **Always** use safety support and block the wheels. When performing maintenance, never use a jack to support the machine. Assist the jack with blocks or other adequate support.
- Use extreme caution when making adjustments.
- When disconnecting hydraulic lines, shut off hydraulic supply and relieve all pressure.
- Never use hands to locate a hydraulic leak on attachments. Use a piece of cardboard or wood. Hydraulic fluid escaping under pressure can penetrate the skin.
- Openings in the skin and minor cuts are susceptible to infection from hydraulic fluid. **If injured by escaping hydraulic fluid, see a doctor at once. Gangrene can result. Without immediate medical treatment, serious infection and reactions can occur.**
- When installing, replacing, or repairing hydraulic system cylinders or parts, make sure that the entire system is charged and free of air before resuming operations. Failure to bleed the system of all air can result in improper machine operation, causing severe injury.
- After servicing, be sure all tools, parts, and service equipment are removed.
- Never replace hex bolts with less than grade five bolts unless otherwise specified.
- Where replacement parts are necessary for periodic maintenance and servicing, genuine factory replacement parts must be used to restore your equipment to original specifications. The manufacturer will not claim responsibility for damages as a result of the use of unapproved parts and/or accessories.
- If equipment has been altered in any way from original design, the manufacturer does not accept any liability for injury or warranty.

## MAINTENANCE AND SERVICE SCHEDULE

- Prior to each use, check for loose bolts and replace lost or worn parts.
- Grease hinge pins before each use when necessary.  
Note: Clean grease fittings and replace those that are broken or missing.
- Inspect and repack wheel bearings at the beginning of each year.
- Remove dirt and debris from the harrow sections before storage.
- Parts diagrams and listings for service and repair references may be found in appendix B.

## OPERATING SUGGESTIONS

- To maximize the harrow's performance, it should be towed at speeds ranging from six to nine (6 - 9) mph. This keeps the field debris moving through the harrow sections and avoids clogging. The best results will be obtained after the paint has been scoured from the teeth.
- Choose the angle of attack of the harrow teeth based on field conditions. For more information see the section titled Angle of Attack.
- Getting the unit ready for field use includes the following steps (refer to figure 1):
  1. Rotate the cylinder lock bars forward.
  2. Disconnect the tie-bar on the left side and swing it forward and pin it to the stow bracket.
  3. Slowly back up until the wings are slightly ahead of the center bar. As you back up, be sure the wings open evenly.
  4. Secure the wing cables to the cable brackets on the front of the A-frame.
  5. Drive forward until the cables are tight and lower into the field position
  6. Check that the wings are in line with the center bar. If necessary, adjust the wing cable brackets to ensure that the wings are pulled evenly.

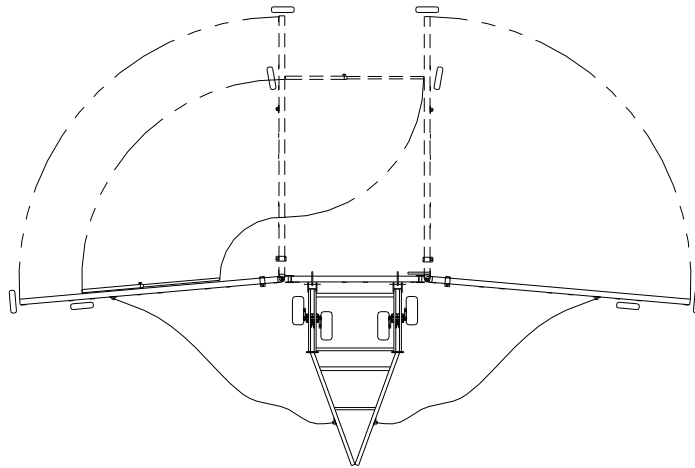
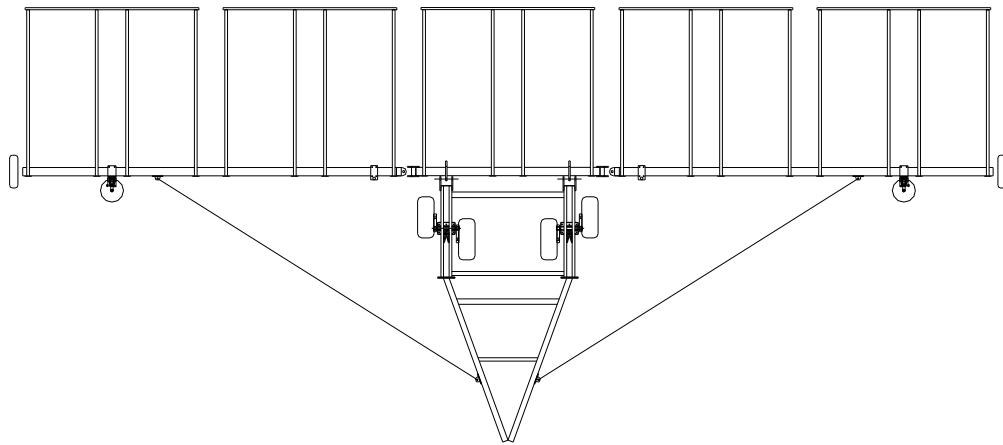


Figure 1A

- Getting the unit ready for transport includes the following steps (refer to figure 1):
  1. Rotate the harrows to the upright position.
  2. Slowly back up until the wing cables are slack and disconnect the cables from the A-frame.
  3. Store the wing cables by wrapping them around the lift arms and then hooking them over cable stow brackets. (Make sure they are off of the ground and clear for transport.)



**Figure 1B**

4. Rotate the cylinder lock bars back into the lock position.
5. Slowly drive forward until the wings are straight back behind the unit.

Note: If this unit has any of the add-on options, refer to those manuals for operation instructions.

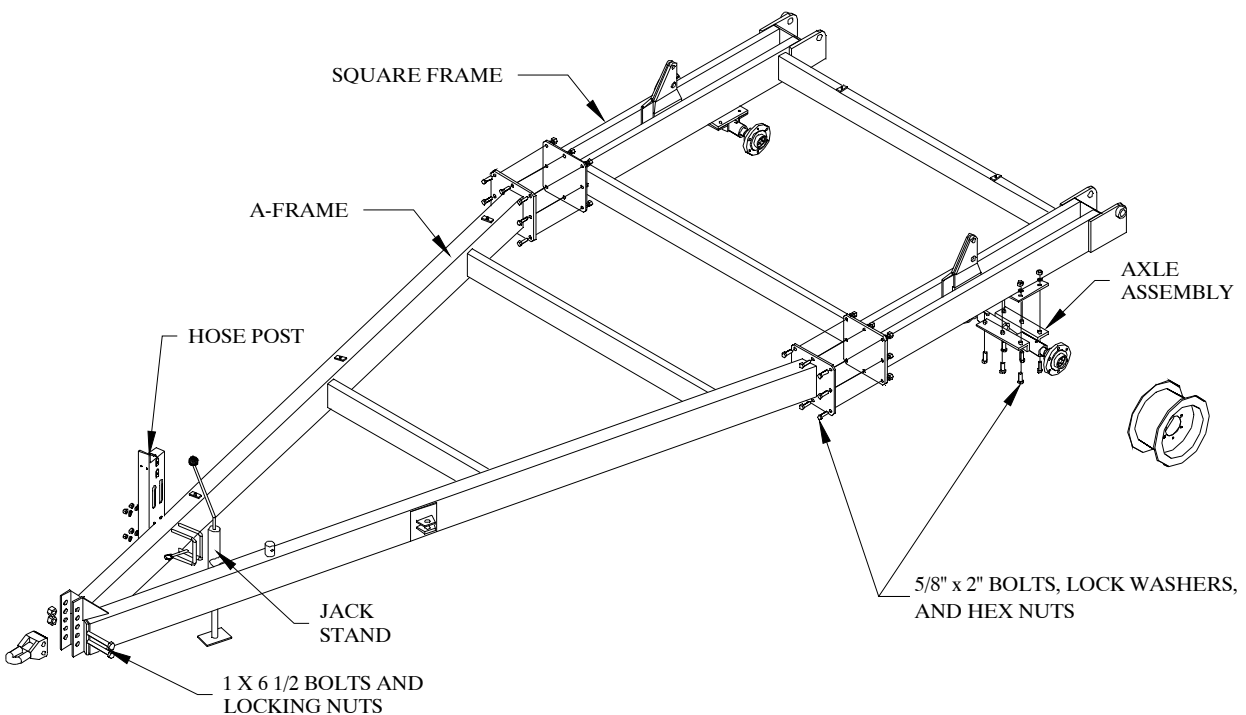
### **ASSEMBLY SUGGESTIONS**

- You will find the machine is easier to assemble if the set-up instructions are followed in the order given in the manual.
- Before beginning, sort the various bolt bags, hardware bags and hydraulic bags according to what part of the unit that is being setup. Refer to the end of the parts listing in appendix B. Only open the bag or bags that are required as the setup instructions are followed.
- Whenever the terms “left” and “right” are used, it should be understood to mean when standing behind and facing the unit. This is also known as the “driver’s left” and the “driver’s right.”
- The term “field position” refers to the position the harrows are in when the unit is being used in the field - that is, with the wings out and the harrow sections down.
- The term “transport position” refers to the position the harrows would be in when the unit is being transported from place to place - that is, with the harrows up and the wings folded and secured with the tie-bar.
- When assembling, make sure the parts are securely held before proceeding to the next step.
- Bolt torque specifications are given in appendix A.
- The hydraulic cylinder and hose requirements are listed in the parts listing in appendix B. It is not recommended that other size cylinders or hoses be substituted. Hoses are marked with the part number near the ends. The last three digits indicate the hose length in inches. Fittings with a restrictor are marked with an ‘R’.
- A dual acting hydraulics supply is required. The unit is designed for the standard ASAE pressure of 1500 psi.
- Tire requirements are also listed in the parts listing in appendix B.
- Layout diagrams for each unit may be found in appendix C. Mark the page with the diagram that refers to your unit, it will be referred to periodically throughout the manual.

## STEP - BY - STEP ASSEMBLY INSTRUCTIONS

### Main Frame Assembly

1. Bolt the square frame to the A-frame. Refer to Figure 2. Use sixteen 5/8" x 2" bolts, lock washers, and hex nuts.
2. Bolt the main frame axle assemblies to the frame. Use twelve 5/8" x 2" bolts, lock washers, and hex nuts.
3. Mount the wheels with 11L x 15 tires on the main frame axle assemblies.
4. Attach the 10" jack to the A-frame. Attach the hose post using the 1/2 x 8 x 5 u-bolts, lock washers and hex nuts.

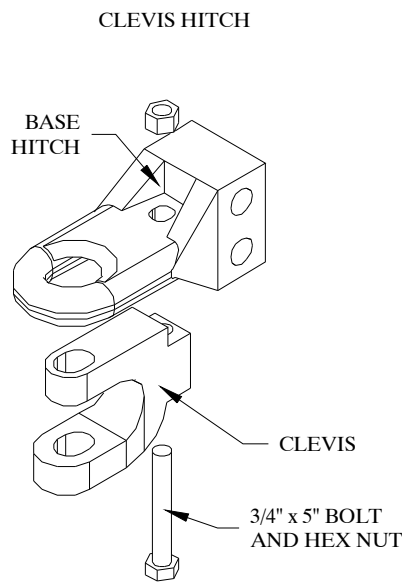


**Figure 2**

5. Assemble either a clevis hitch (Figure 3) or a pintle hitch (Figure 4) as required by the tractor or towing vehicle. Note the opposite orientation of the base hitch for each hitch type. Attach the hitch assembly to the A-frame with two 1" x 6 1/2" bolts and locking nuts.

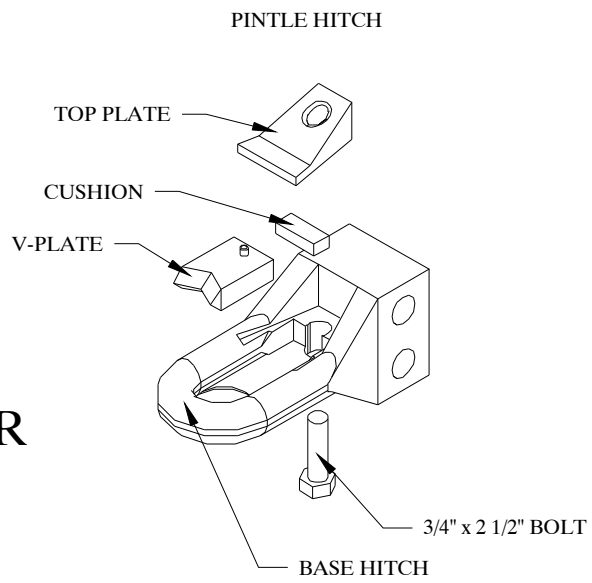
Parts have been provided to assemble a clevis hitch or a pintle hitch. Not all the included parts will be needed to assemble either type of hitch. Be sure to store the extra parts in a safe place; they will be needed if one requires the use of the other hitch type.

Note: For clarity purposes, the rest of the diagrams will be shown with out the main axles and rims.



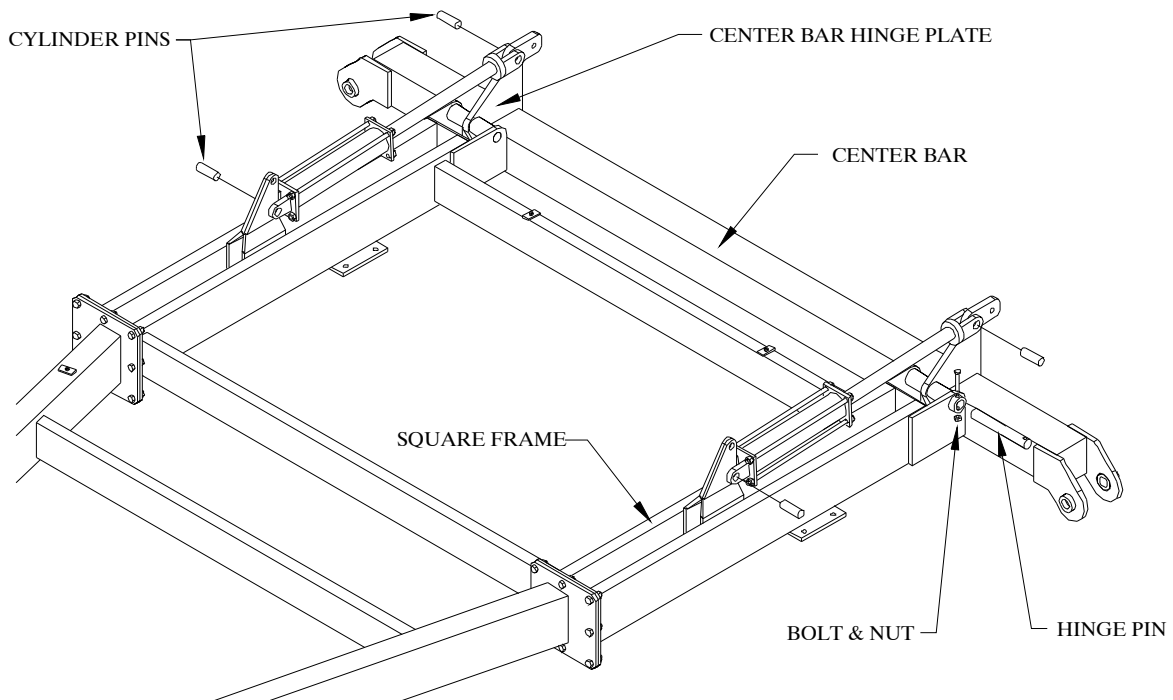
**Figure 3**

OR



**Figure 4**

**Attach the Center Bar to the Square Frame**

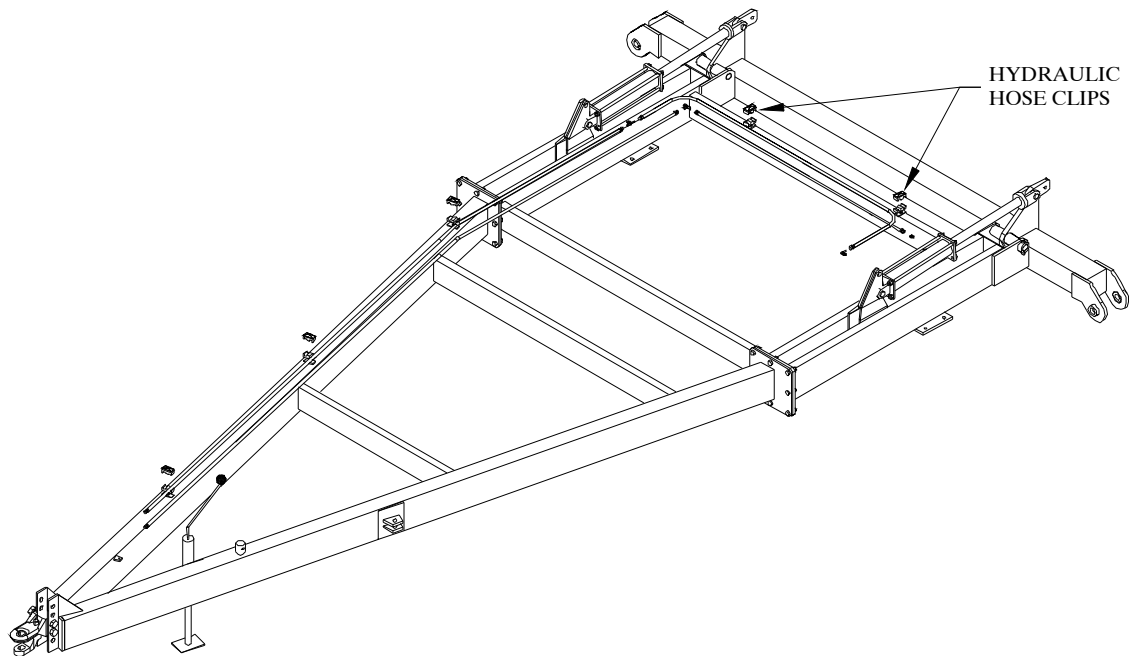


**Figure 5**

1. Attach the center bar to the square frame. Refer to Figure 5. Use the 1 1/2" x 11 1/16" hinge pins, 1/2" x 3" grade 8 bolts, and locking hex nuts.
2. Without using the hydraulics, attach the ASAE 5" x 16" cylinders to the cylinder posts on the square frame and to the center bar hinge plate. Note the locations of the ports and the direction of travel. Use the 1 1/4" x 6 3/4" cylinder pins with 3 holes. The extra portion of the pin should be position to the outside of the unit.

## **Install the Main Frame Hydraulics**

Refer to Figure 6 and the hydraulic system diagram in appendix B for more details.



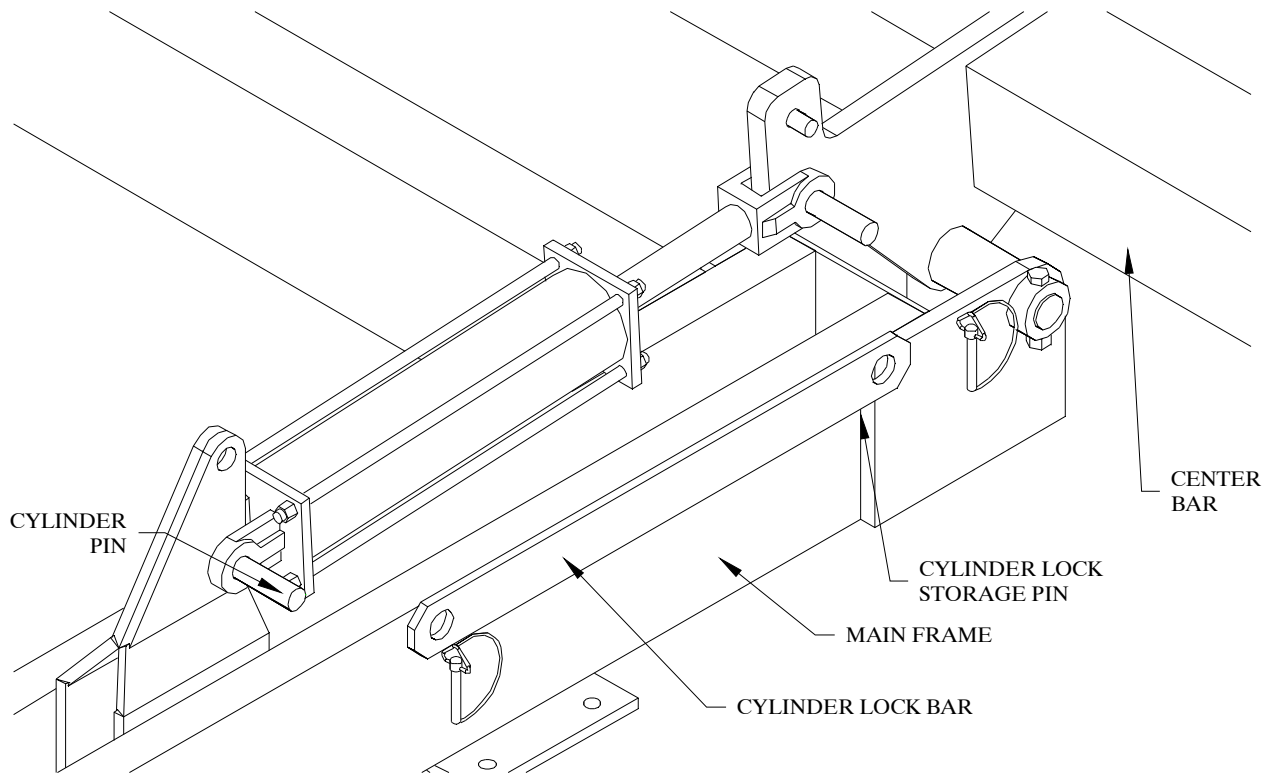
**Figure 6**

1. Insert all fittings into each of the ports on the cylinders. For proper placement of fittings, refer to the diagram and listing in appendix B. Do *not* over tighten.
2. Connect all hoses as shown above and in appendix B.
3. Attach the hoses to the frame by bolting the dual hose clips to the weld plates on the frame.

Before further assembly, the hydraulic system must be filled with oil. Attach the unit to a tractor and connect the hydraulic lines. Using hydraulic controls rotate the center bar and wings several times to fill the cylinders and hoses with oil.

### **Attach the Cylinder Lock Bars**

Bolt the cylinder lock bars to the cylinder posts on the main square frame. Refer to Figure 7. Use the lynch pins provided to secure into place. Note the location of the storage pin for the cylinder lock bar when the unit is in the field position. Use the bridge pin provided.



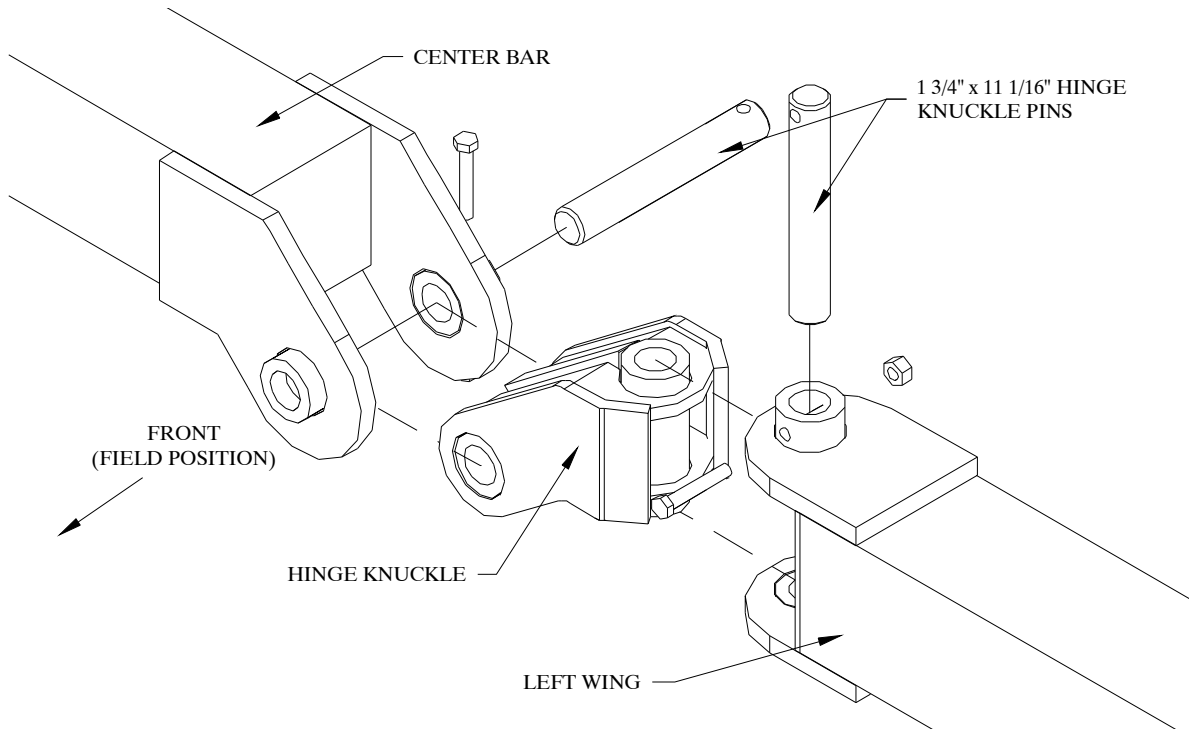
**Figure 7**

### **Attach the Wings to the Center Bar**

1. Attach the hinge knuckles to the center bar. Use 1 3/4" x 11 1/16" hinge knuckle pins, 5/8" x 4 1/2" grade 8 bolts, and locking hex nuts. Refer to Figure 8.
2. Attach the wings to the hinge knuckles using the remaining 1 3/4" x 11 1/16" hinge knuckle pins, 5/8" x 4" grade 8 bolts, and locking hex nuts. The wing axle end plate should be offset towards the front of the unit as shown in figure 9.

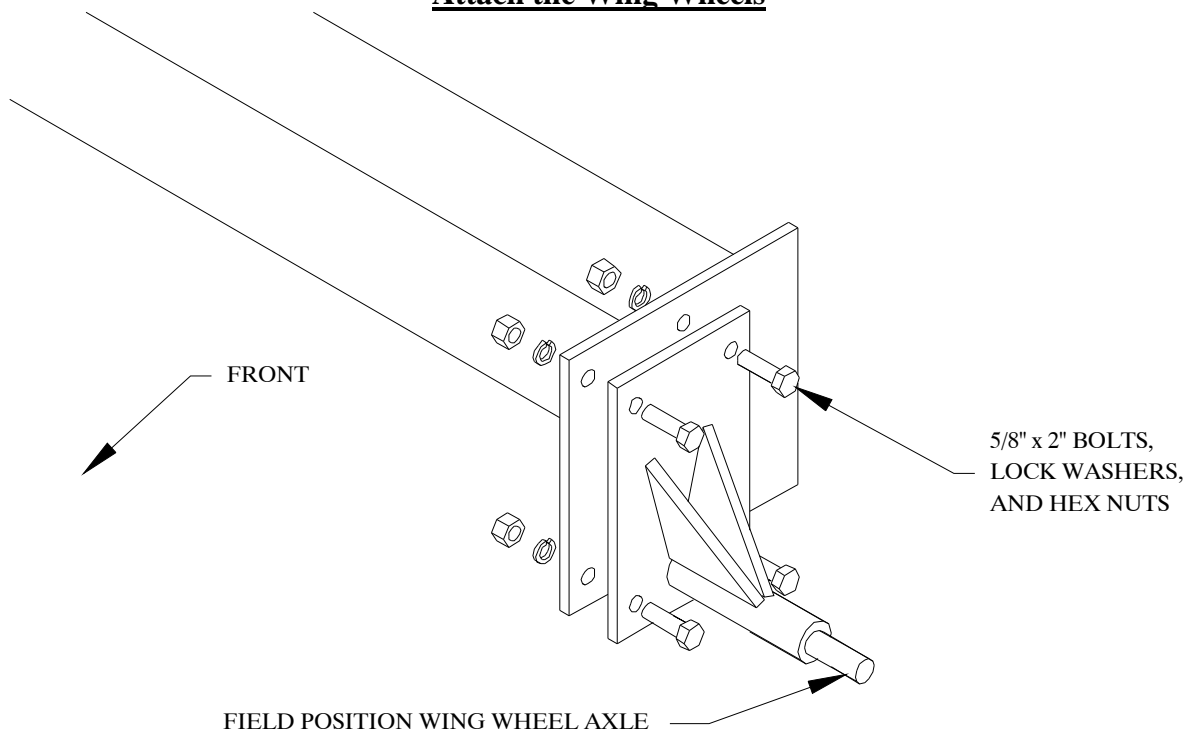
\*NOTE: Be sure the wings are orientated correctly. Both wings are marked left hand and right hand and a visual reference can be made by looking at Figure 10.





**Figure 8**

**Attach the Wing Wheels**



**Figure 9**

1. Mount the field position axles to the ends of the wings as shown in Figure 9 (note the location of the gussets). Use eight 5/8" x 2" bolts, lock washers, and hex nuts.
2. Mount the wheels with 11L x 15 tires on the wing wheel axle assemblies.

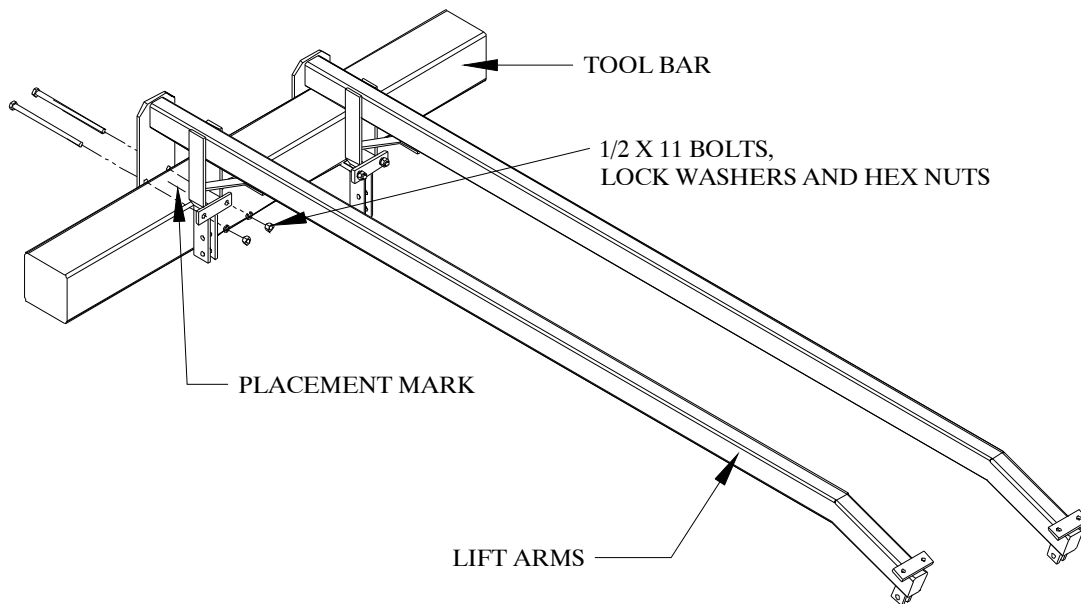
## Harrow Configurations

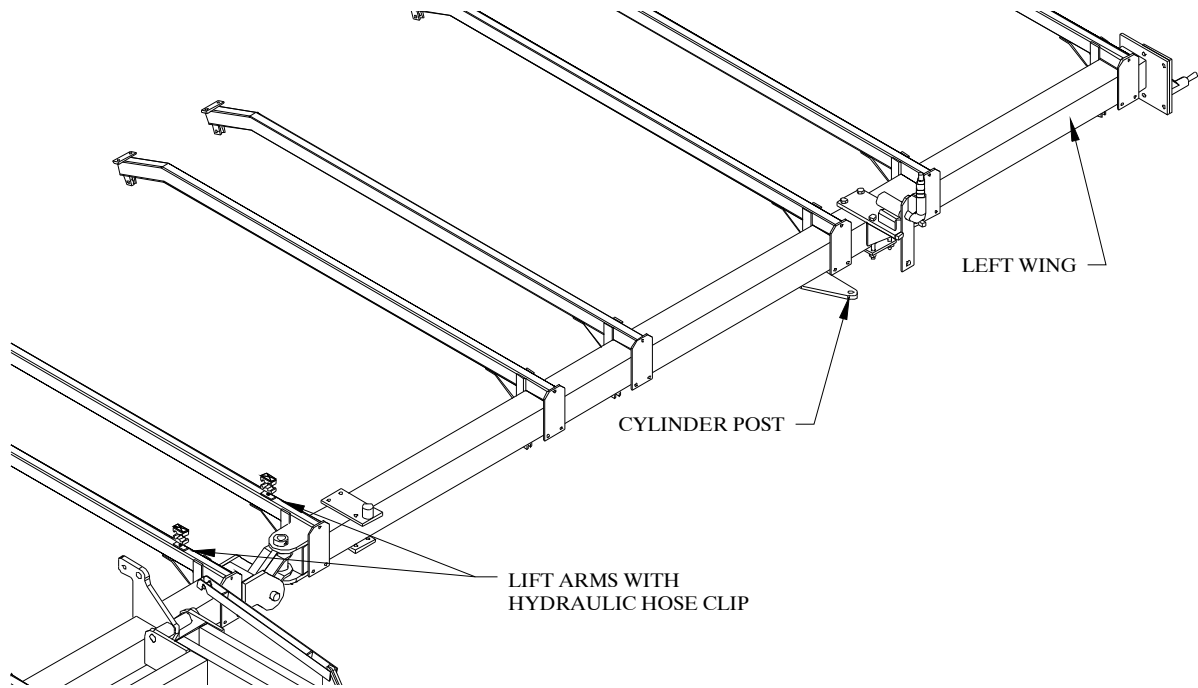
McFarlane harrow sections may be attached in any one of several distinct configurations: 8-bar, 4+4-bar, 12-bar, 8+4-bar, 16-bar, and 8+8-bar. The 8, 12, and 16-bar harrow configurations utilize a single set of pull points located adjacent to the center bar and wings. The 4+4, 8+4, and 8+8-bar harrow configurations (also known as dual sections) also utilize a second set of pull points located at the rear end of the lift arms. Persons assembling an 8, 12, or 16-bar harrow should **ignore** the instructions in *italics* describing the attachment of the rear pull points. Those assembling a dual section harrow should be sure to **follow** the instructions for attaching the rear pull points in *italics*.

### Mount the Lift Arms

1. Refer to the appropriate layout diagram in appendix C. Place a mark on the center bar and wings at the locations for each of the lift arms. Be sure the dimensions are for your unit.
2. Center a lift arm on each of these marks and secure using two ½” x 11” bolts, lock washers, and hex nuts for each lift arm. Refer to Figure 10.

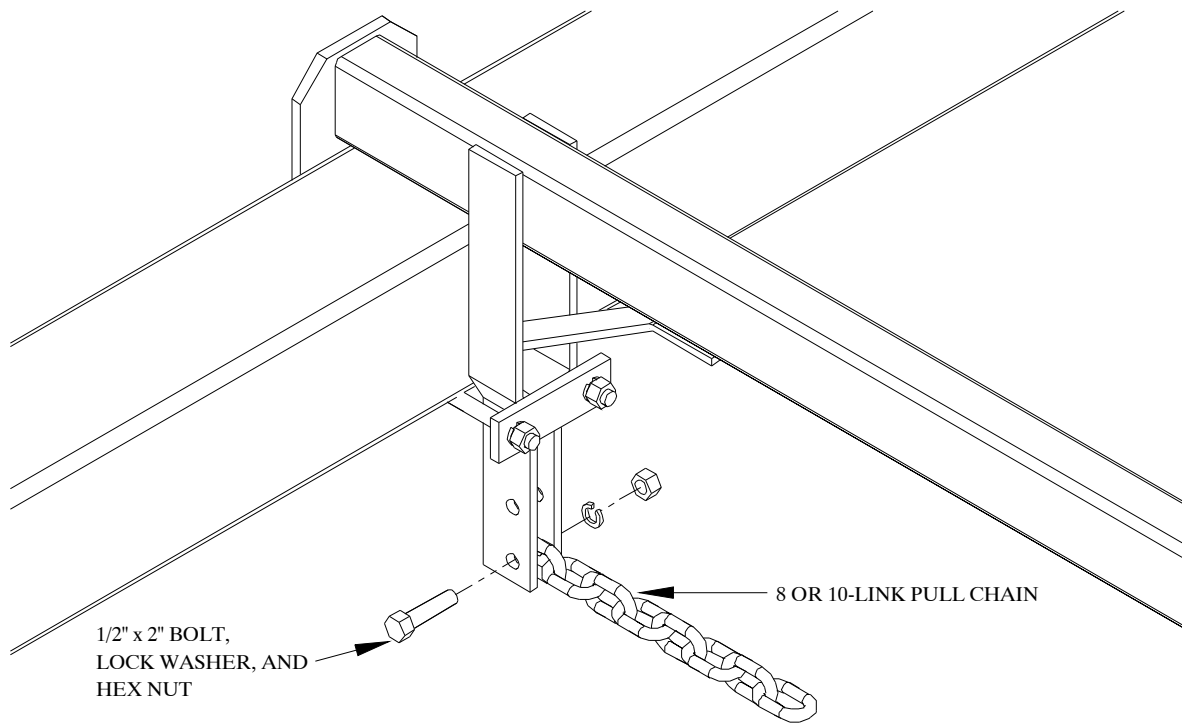
\* NOTE: The Hydraulic Transport option includes four lift arms that have a hydraulic hose clip welded to them. They are to be installed on either side of the hinge knuckle on the center bar and wings. See the figure below.





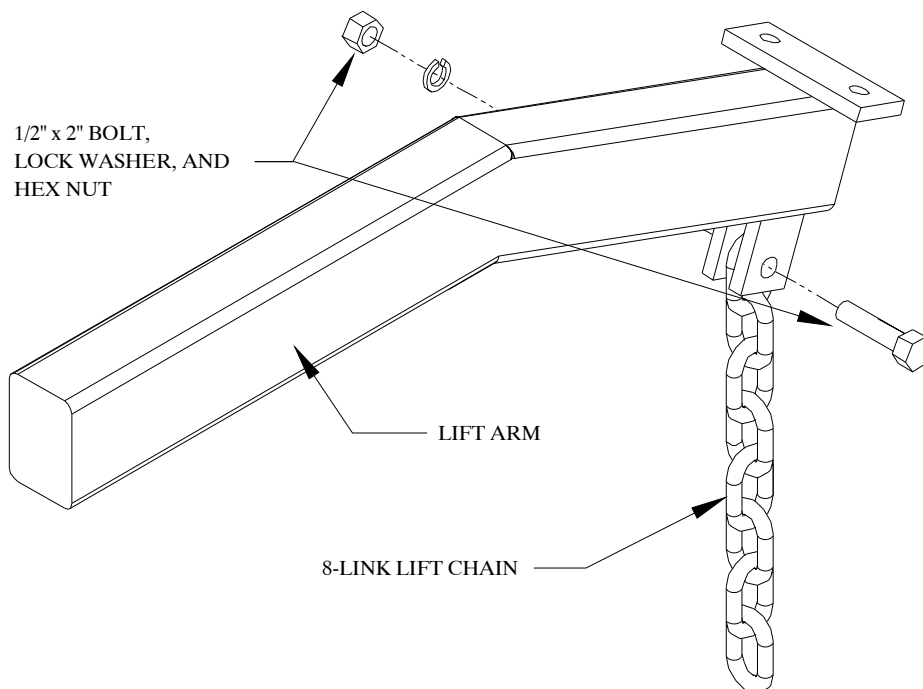
**Figure 10**

3. Bolt an 8 or 10-link pull chain in between each of the lift arm pull points. (10-link for 8-bar harrow sections; 8-link for all other configurations.) Use 1/2" x 2" bolts, lock washers, and hex nuts. Refer to Figure 11.

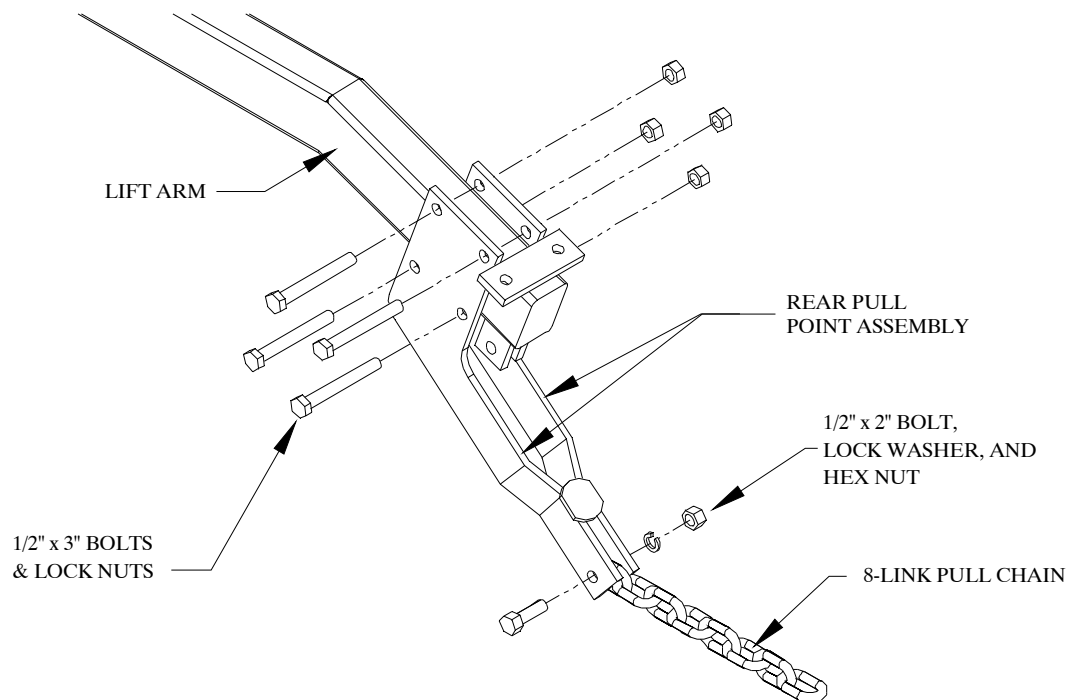


**Figure 11**

4. Bolt an 8-link lift chain between the chain tabs at the rear end of each lift arm. Refer to Figure 12. This chain will go down and connect to the last bar of a 4 or 8-bar harrow section or to the connector link for 16-bar sections.



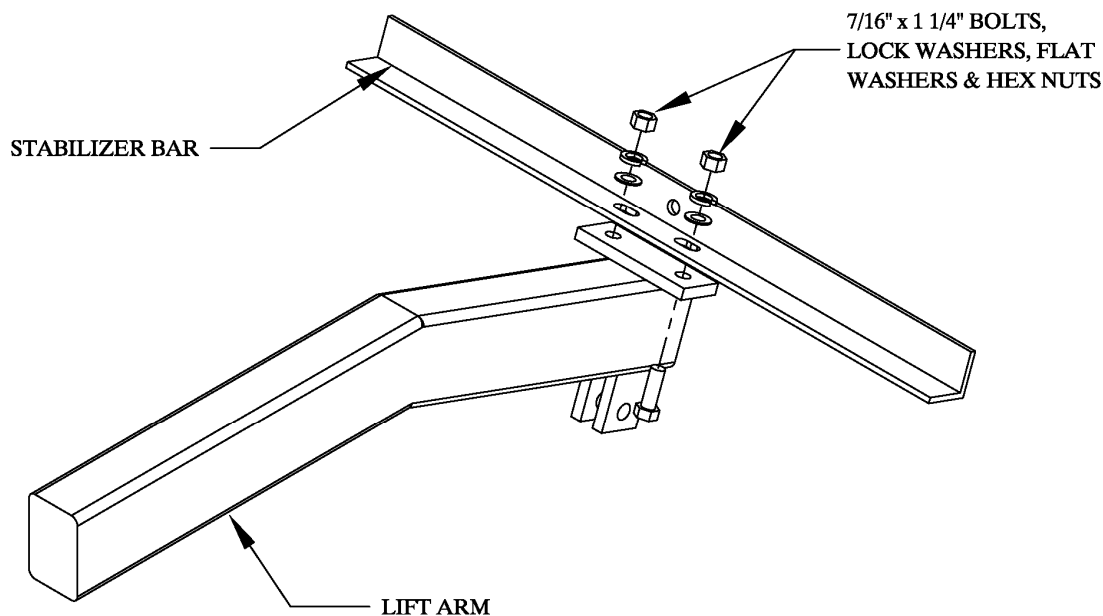
**Figure 12**



**Figure 13**

5. Attach a rear pull point assembly to the rear end of each lift arm. Use four 1/2" x 3" bolt and lock nuts. Refer to Figure 13.

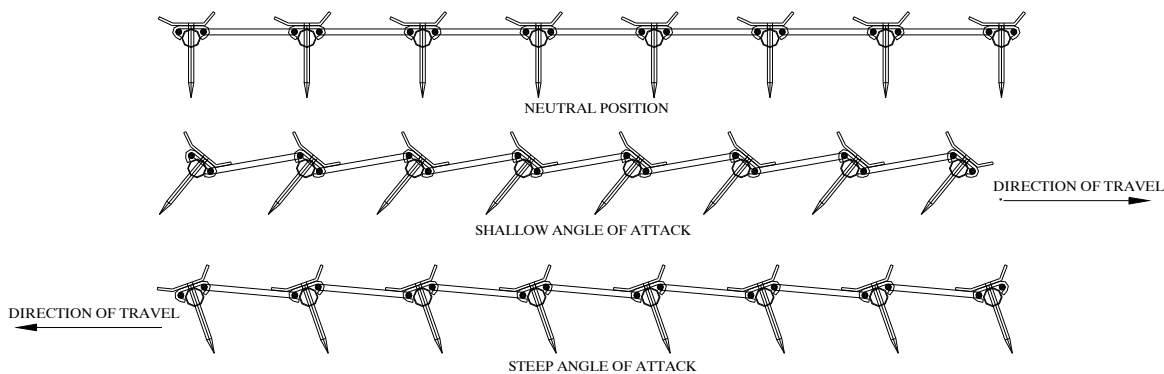
6. Bolt an 8-link pull chain to the end of the rear pull point assembly with a 1/2" x 2" bolt, lock washer, and hex nut. Refer to Figure 13. This chain will connect to the first bar of the second set of harrow sections.
7. Refer to the layout diagrams in appendix C for the locations of the different lengths of stabilizer angles. Bolt the stabilizer angles to the bolt plates near the rear end of the lift arms. Refer to Figure 14. Use 7/16" x 1 1/4" bolts, lock washers, flat washers and hex nuts.



**Figure 14**  
**Angle of Attack**

Before actually placing the harrows, you may want to determine the ‘angle of attack’ desired for your particular application. Refer to Figure 15 to help clarify what is meant by ‘angle of attack.’ McFarlane flexible harrow sections have a built-in system which allows the harrow owner a choice between a steep or shallow angle of attack. To change the angle of attack, simply reverse the harrow section and pull it from the other end.

Each angle has its advantages and disadvantages. The steeper the angle of attack, the more aggressive the harrowing action. However, the steeper the angle, the greater the tendency there is for the sections to clog with field debris.



**Figure 15**

## **Harrow Identification**

The number of teeth on a bar is the same as the first digit of the harrow identification number. The last number is the number of bars per section. An FH-600-8 would have six teeth per bar and 8 bars; an FH-800-8 would have eight teeth per bar and 8 bars.

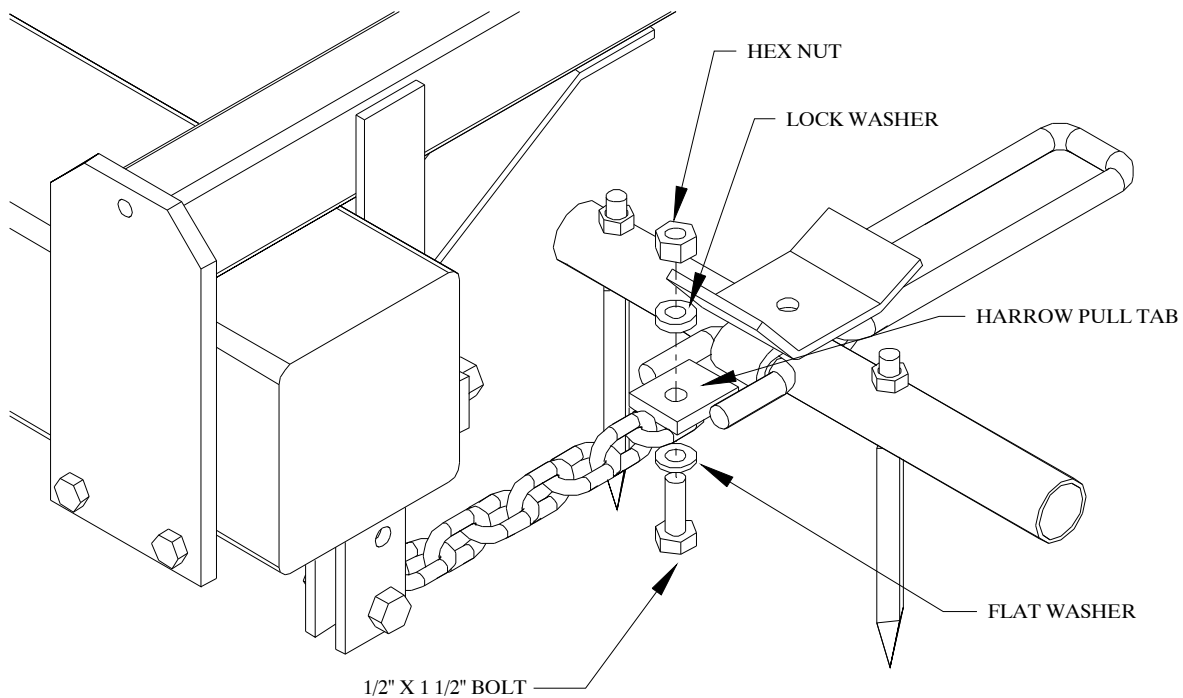
## **Attach the Harrow Sections**

Now that you have determined the desired angle of attack and identified the harrow sections, position the harrow sections on the ground under each pair of lift arms. Refer to the layout diagrams in appendix C to determine the placement of the harrow sections.

Instructions follow for attaching the harrow sections. Be sure to follow the instructions corresponding to your configuration.

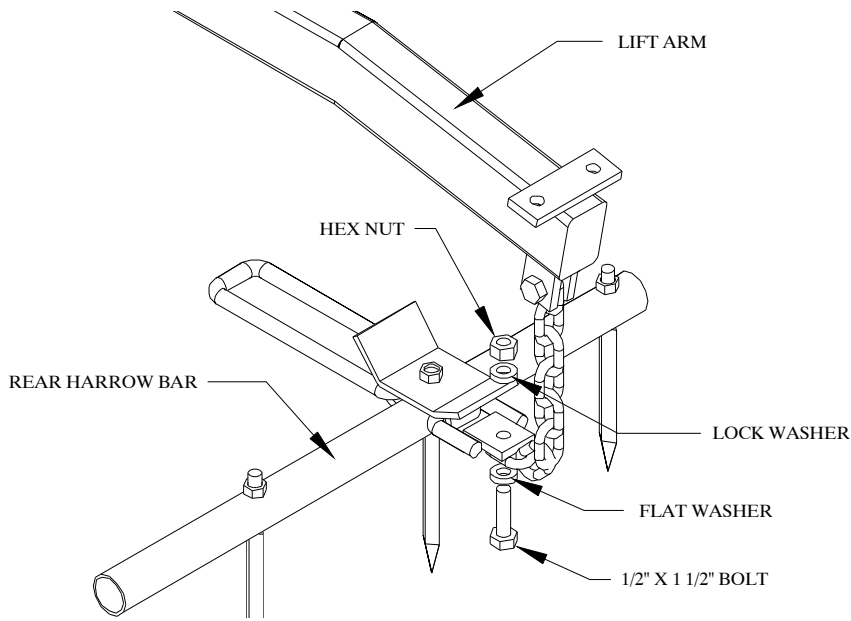
## **Connect an 8-Bar Section**

1. Bolt the pull chains to the front tabs on the harrow sections. Refer to Figure 16. Use  $\frac{1}{2}$ " x  $1\frac{1}{2}$ " bolts, flat washers, lock washers, and hex nuts. The chains should be bolted to the bottom of the pull tabs. Make sure that the chains are not twisted.



**Figure 16**

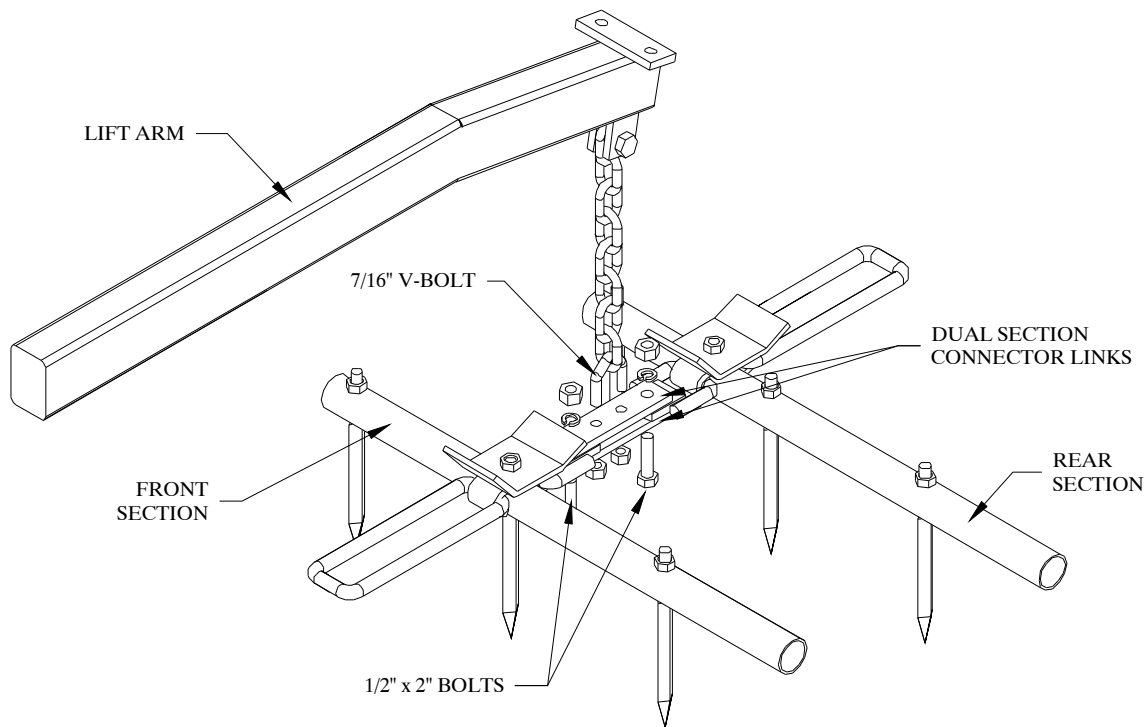
2. Bolt the lift chains to the bottom of the rear lift tabs of the harrow sections. Refer to Figure 17. Use  $\frac{1}{2}$ " x  $1\frac{1}{2}$ " bolts, flat washers, lock washers, and hex nuts. Make sure the chains are not twisted.



**Figure 17**

**Connect a 12 or 16-Bar Section**

1. Bolt the pull chains to the front tabs on the front harrow sections. Refer to Figure 16. Use ½” x 1 ½” bolts, flat washers, lock washers, and hex nuts. The chains should be bolted to the bottom of the pull tabs.
2. Bolt the front and rear harrow sections together using two 5/16” x 1 ½” x 6” dual section connector links at each pull tab. Refer to Figure 18. Use two ½” x 2” bolts, lock washers, and hex nuts. Do *not* tighten yet.
3. Bolt the lift chains to the dual section connector links. Use one 7/16” V-bolt and two lock nuts on each link. Tighten all dual section connector link bolts.
4. Make sure that the harrow sections match each other, the angle of attack is correct, and the chains are not twisted.



**Figure 18**

**Connect Dual Sections**

1. Bolt the pull chains to the front tabs on the harrow sections. Refer to Figures 16 and 19. Use ½” x 1 ½” bolts, flat washers, lock washers, and hex nuts. The chains should be bolted to the bottom of the pull tabs.
2. Bolt the lift chains to the bottom of the rear lift tabs of the front harrow sections. Refer to Figure 19. Use ½” x 1 ½” bolts, flat washers, lock washers, and hex nuts.
3. Make sure that the harrow sections match each other, the angle of attack is correct, and the chains are not twisted.



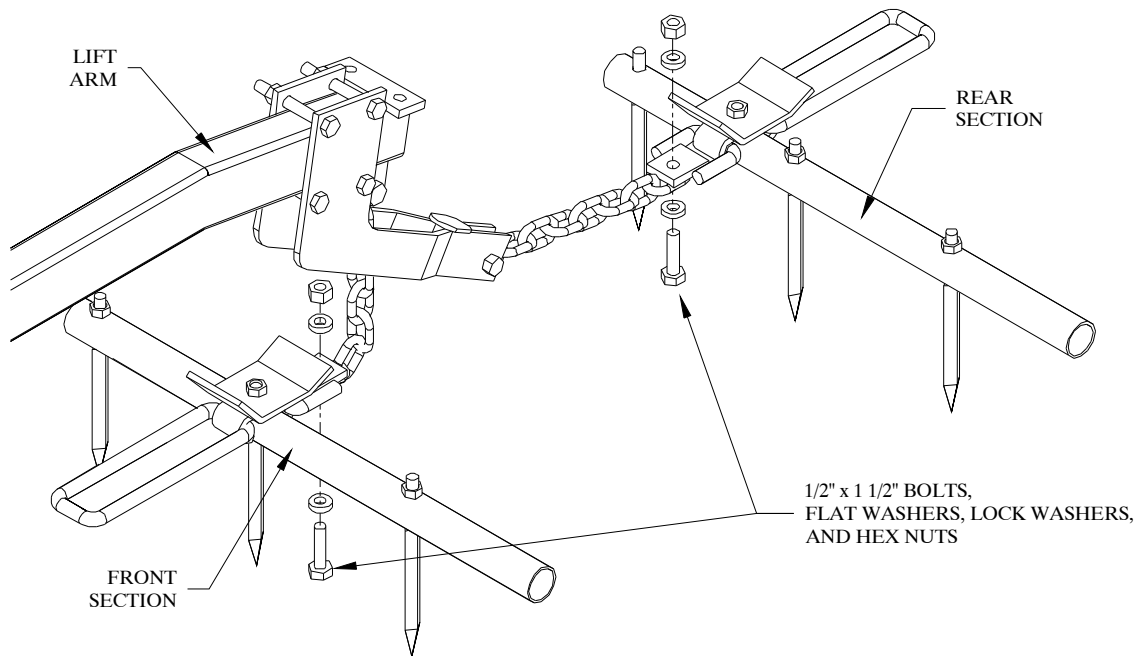


Figure 19

For the next two steps you will need enough room to lower both wings completely. **Be sure the unit is attached to a tractor of adequate size before actuating the hydraulics!**

### Attach the Transport Wheels

1. Attach the transport wheel axle assemblies to the wings between the 2<sup>nd</sup> and 3<sup>rd</sup> lift arms (counting from the field position wing wheel end of the wings). Use 3/4" x 10" bolts, lock washers, and hex nuts. If installing the Hydraulic Transport option, be sure to mount it 10" from the flat edge of the hydraulic transport cylinder post. Refer to Figure 20. Note that there are right and left hand transport axle assemblies. When the spindle is orientated in the vertical direction (field position) as shown in Figure 20, the spindle plate should be in contact with the front stop block.

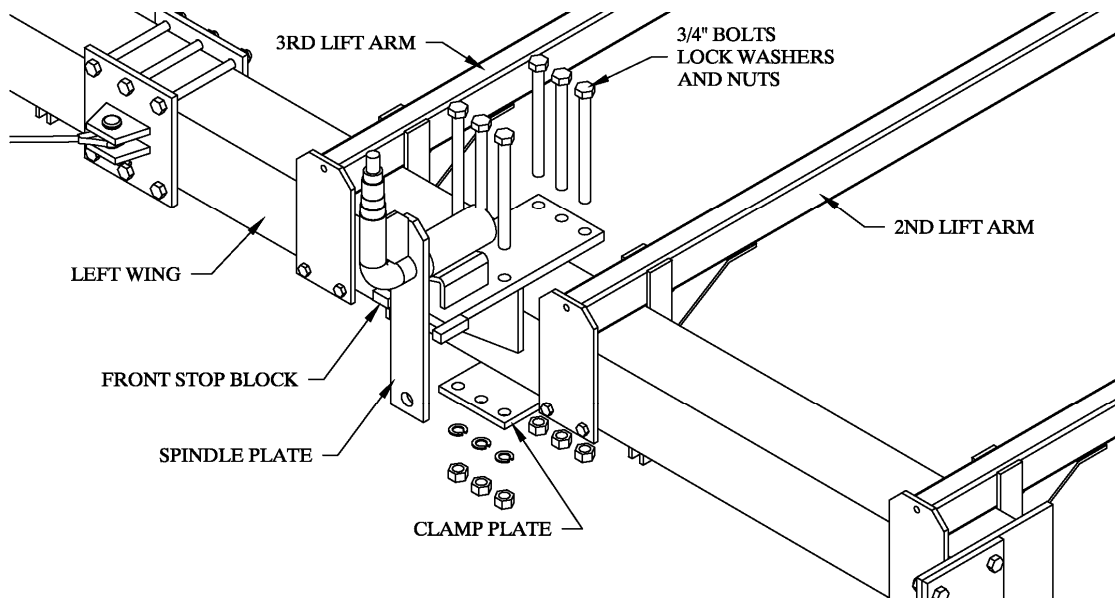
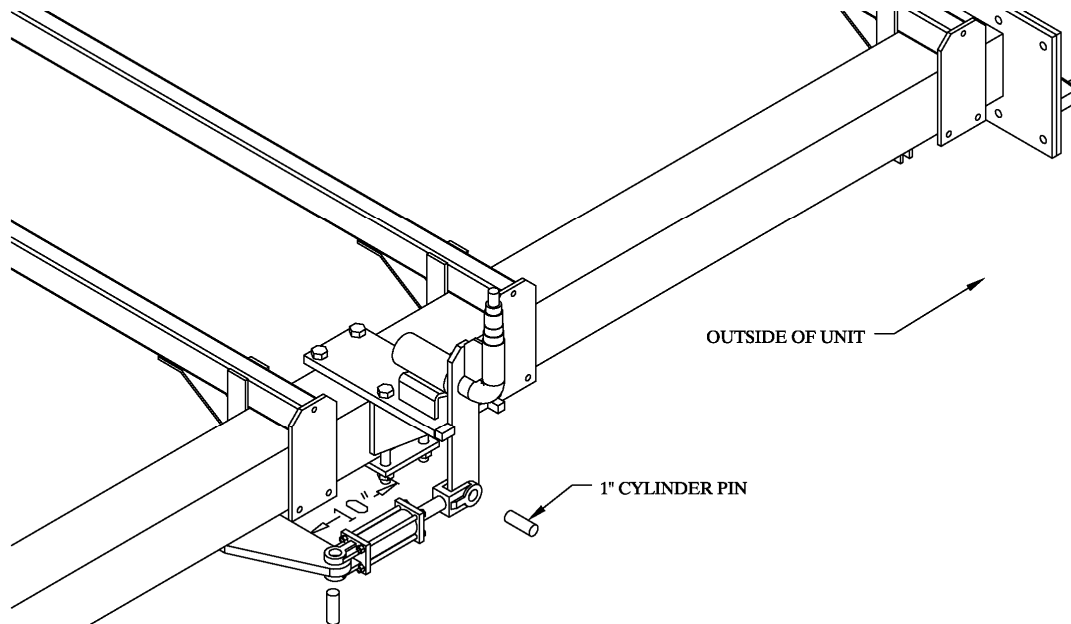


Figure 20

2. Attach the hydraulic cylinders with the open ports facing down as shown. Refer to Figure 21. Connect the rod end of the cylinder to the transport wing wheel axle and the base end of the cylinder to the fixed cylinder post. Note: When the cylinder is fully retracted the transport wing wheel should be in line with all other transport wheels so that the entire unit can be pulled straight.
3. Mount the wheels with 11L x 15 tires on the hubs.



**Figure 21**

\*Note: For the hydraulics layout refer to the diagram in appendix B.

4. Run the 290" hoses along the right side of the main frame back to the center bar.
5. Bolt the hydraulic hose tee post to the center bar 6" from the center bar hinge plate as shown in Figure 22. Use a 1/2 x 6 x 7 3/4 U-bolt, lock washers and hex nuts.
6. Attach the hydraulic tees to the tee brackets by inserting the long leg of a tee through the tee bracket and securing with a tee nut.
7. Attach the two remaining longer hoses to the left port of the tee and run to the left hand transport cylinder. The hoses should pass through the brackets of the lift arms and at the hinge knuckles should run across the tops of the hydraulic hoses clips that are on the lift arms.
8. Repeat for the right hand wing using the two remaining shorter hoses.
9. Connect all hoses to the transport position wing wheel cylinders. The hoses from the top tee should be connected to the base end of the cylinders and the hoses from the bottom tee should be connected to the rod end of the cylinders. Be sure the hoses will not catch on the rotating transport wing wheel axle assemblies when the cylinders are actuated.
10. Secure the hoses to the hydraulic hose clips near the hinge knuckles. Be sure to pull the slack from both ends of the hoses to the hinge knuckle between the two hose clips. Secure the hoses to the center bar and wings with pull ties. Be sure the hoses will not catch on any moving parts

and that there is enough slack between the main frame and the center bar for the unit to be folded into the transport position.

11. Attach the 326" main frame hoses to the tees on the center bar. Secure the hoses to the main frame by using the stacked dual hoses clips. Be sure there is enough slack in the rear for the center bar to rotate.

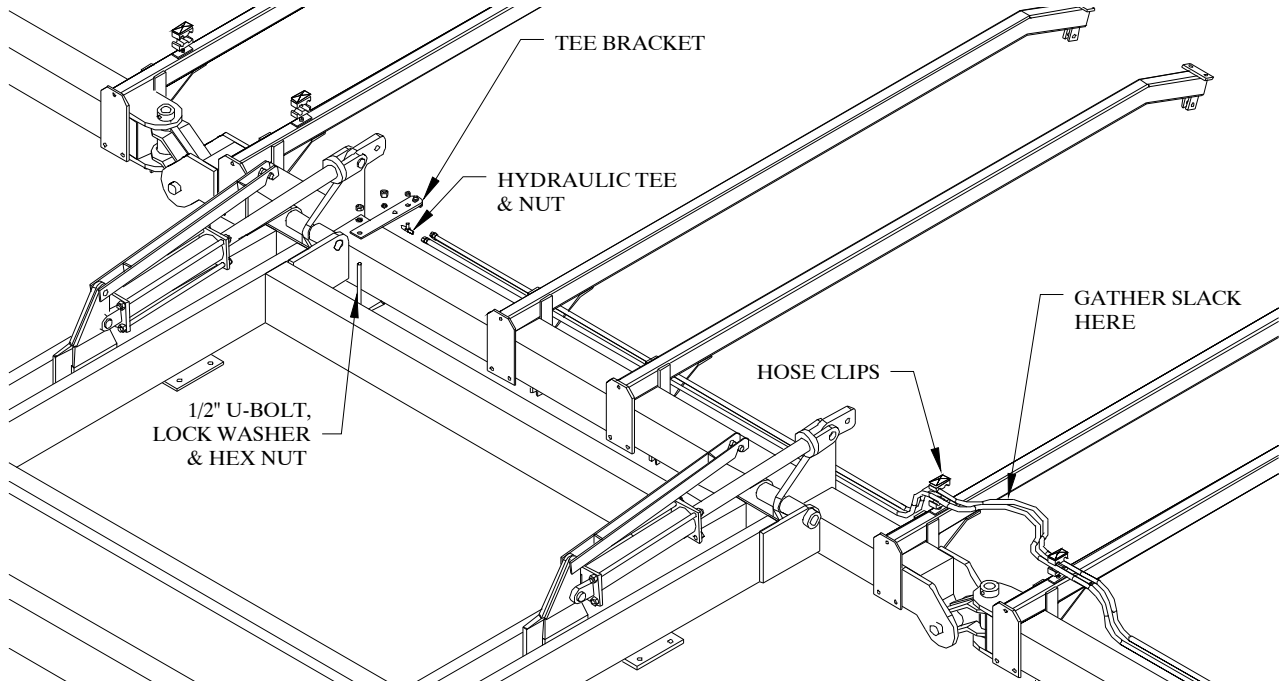


Figure 22

### Attach the Wing Jack Plates

1. Attach the wing jack plates to the wing tubes. Refer to Figure 23. Use 5/8" x 7" x 8 1/2" U-bolts, lock washers, and hex nuts.

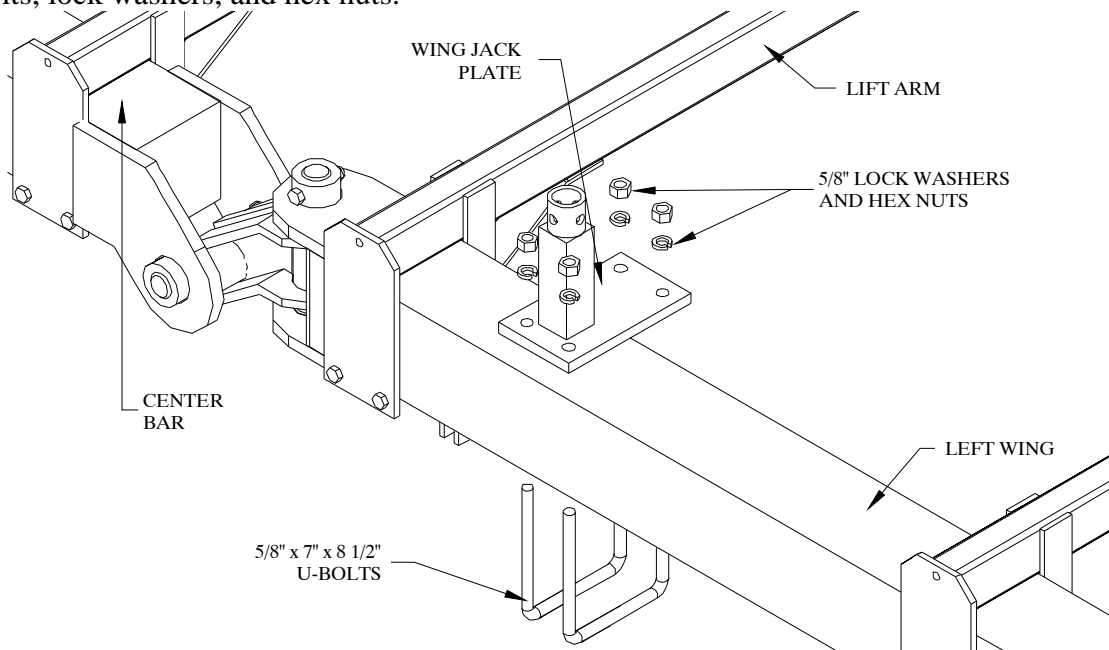
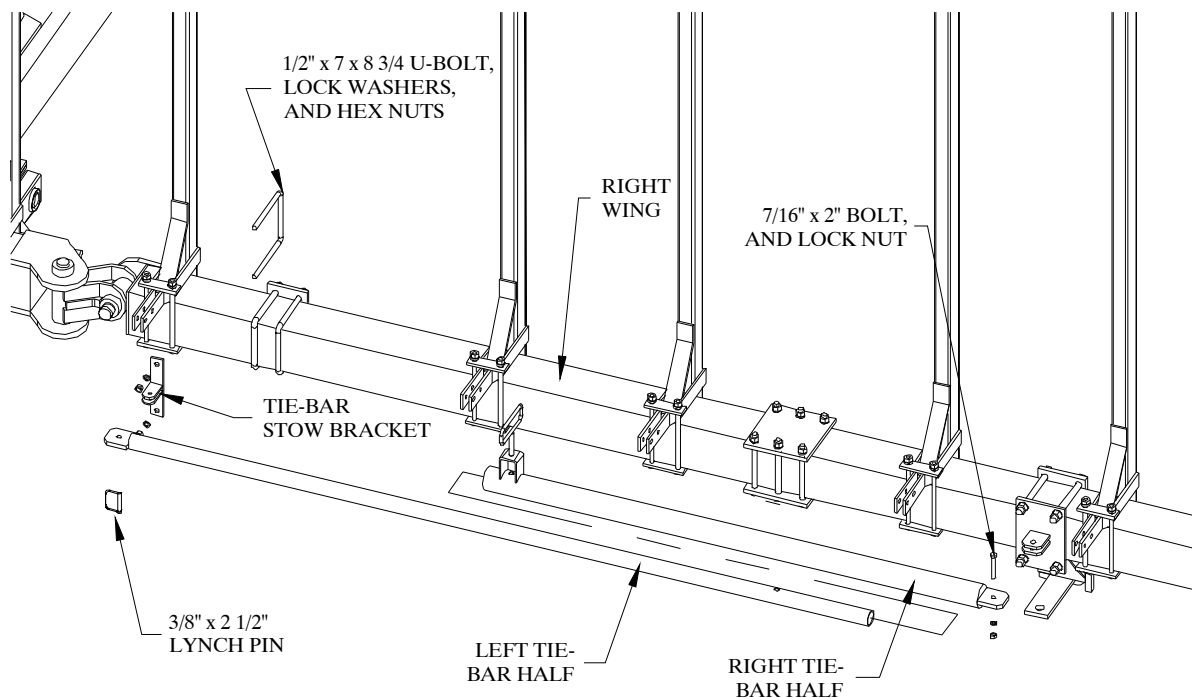


Figure 23

## Attach the Tie-Bar

1. Actuate the main frame hydraulic cylinders to raise the lift arms into the upright position. Secure the cylinders in place with the lock arms.
2. Bolt the right tie-bar half to the tab on the back side of the right transport wheel clamp plate. Refer to Figure 24. Use a 7/16" x 2" bolt and lock nut.
3. Slide the left tie-bar half inside of the right half.
4. Attach the right end of the tie-bar assembly to the tie-bar stow bracket with a 3/8" x 2 1/2" Lynch pin. Bolt the stow bracket to the right wing with 1/2" x 7" x 8 3/4" U-bolts, lock washers, and hex nuts.

For more information on the use of the tie-bar, refer to the operating instructions.

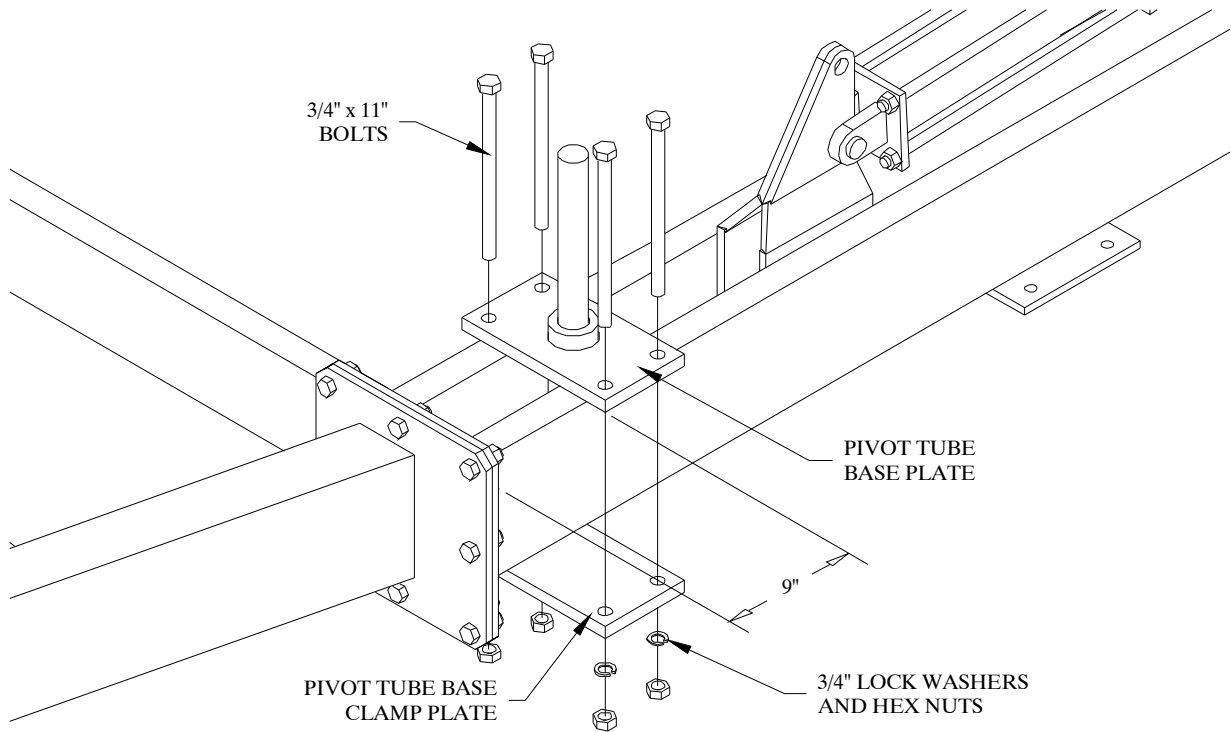


**Figure 24**

*This section refers to attaching the auto-backup bar.*

### **Attach the Main Pivot Tube Bases**

1. Clamp the main pivot arm base to the square frame 9" from the frame splice plate as shown in Figure 25. Use four 3/4" x 11" bolts, lock washers, and hex nuts. Do not tighten the bolts yet.
2. Repeat on the other side.



**Figure 25**

### **Attach the Pivot Arm Assemblies**

Slide the pivot arm assemblies onto the main pivot arm bases with the arms extending out the sides of the cart as shown in Figure 26.

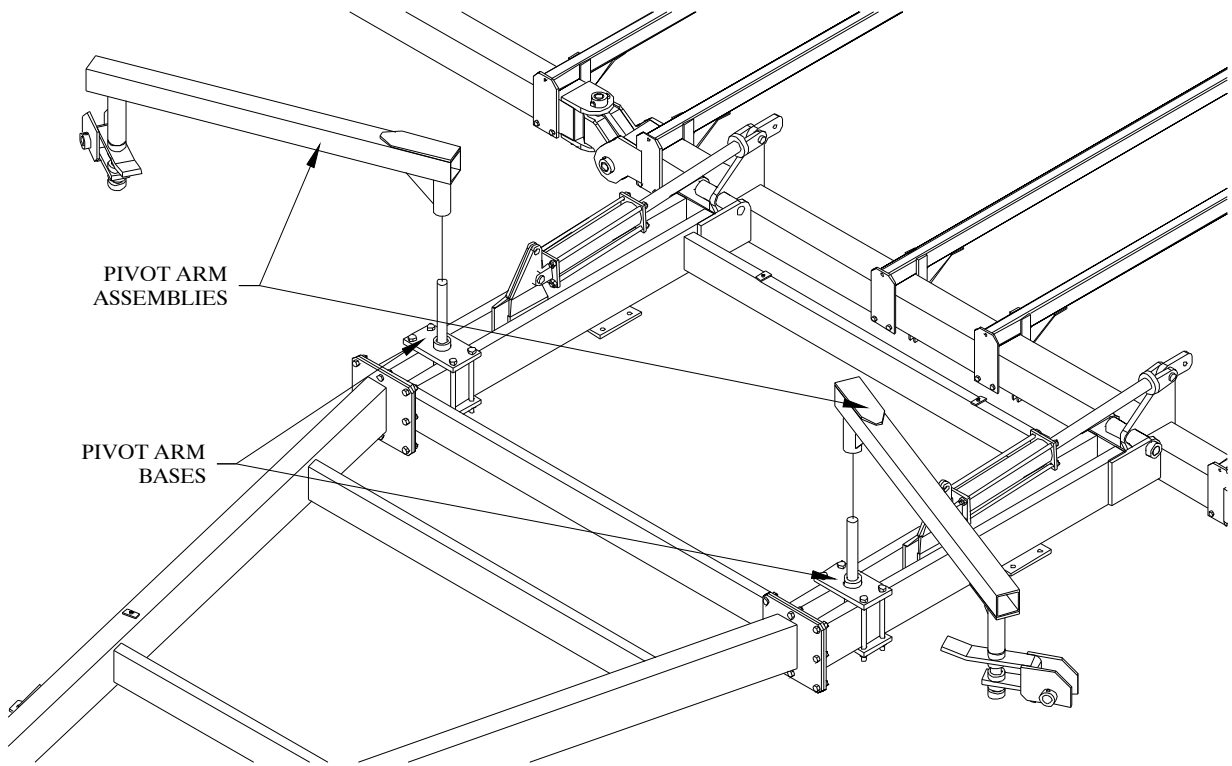


Figure 26

**Attach the Lock Bracket Assemblies**

Attach the lock bracket assemblies to the A-frame 47" from the frame splice plate as shown in Figure 27. Use 5/8" x 6" bolts, lock washers, and hex nuts. Do *not* tighten yet.

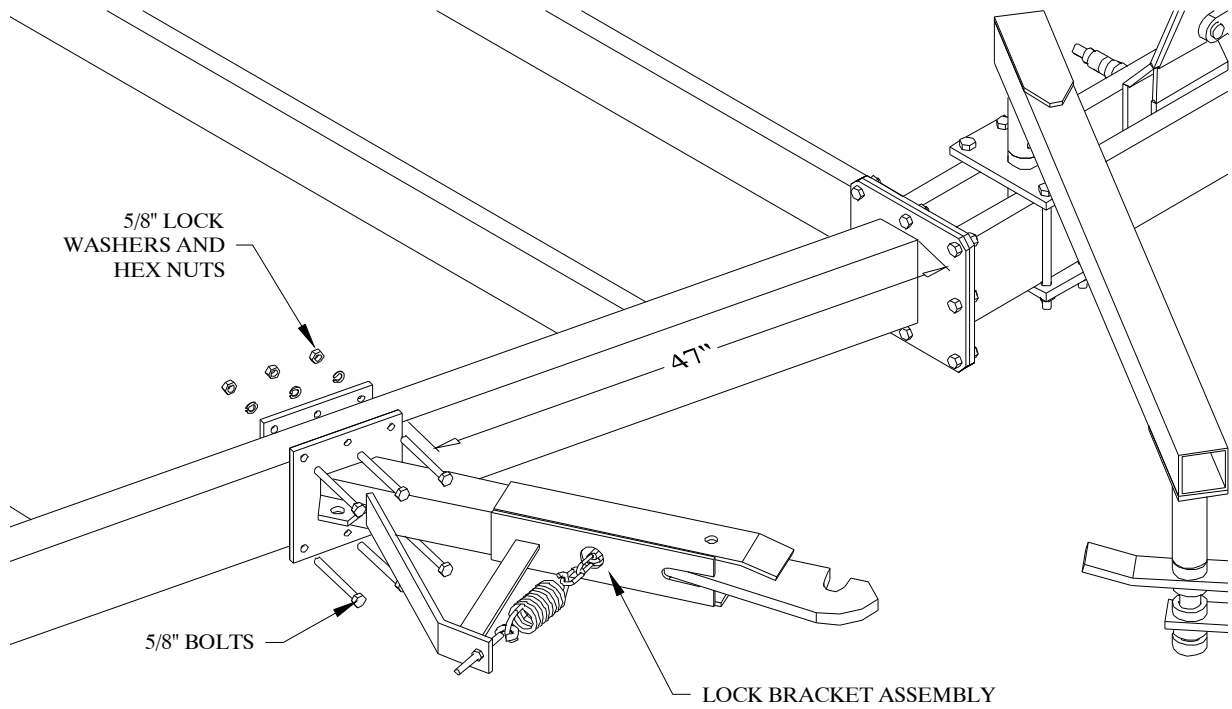


Figure 27

Complete the following steps on each side of the cart. Refer to Figure 28.

1. Loosen the eye bolt and detach the tension spring from the lock arm.
2. Rotate the pivot arm and the lock arm so that they are fully engaged.
3. Reattach the spring and tighten the eye bolt to put tension on the spring.
4. Move the lock arm mounting bracket forward or back on the A-frame to ensure that the pivot arm and lock are fully engaged.
5. Clamp the lock arm assembly in place by tightening the bolts. Check to make sure that the pivot arm and the lock arm are still fully engaged.
6. Attach the  $\frac{3}{4}$ " x 6" yoke to the tab on the lock bracket. Thread the adjuster rod into the clevis until the bushing on the other end of the rod lines up with the two tabs on the A-frame. Secure into place using the 1" x 2  $\frac{1}{2}$ " clevis pins and cotter pins.

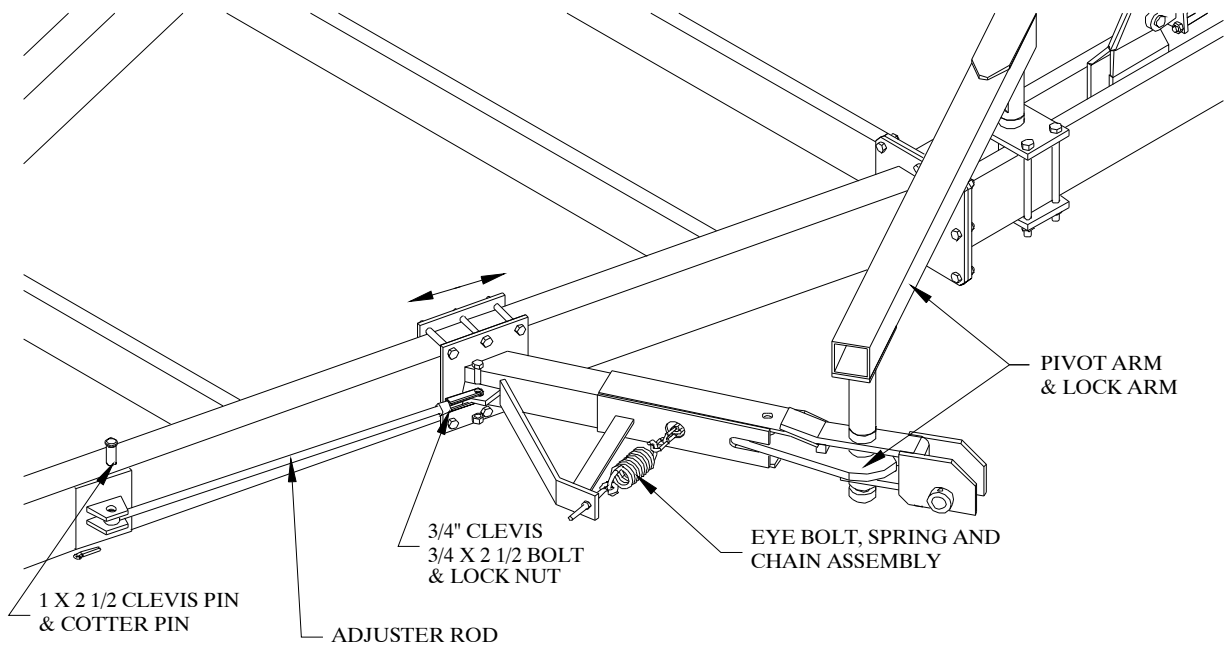
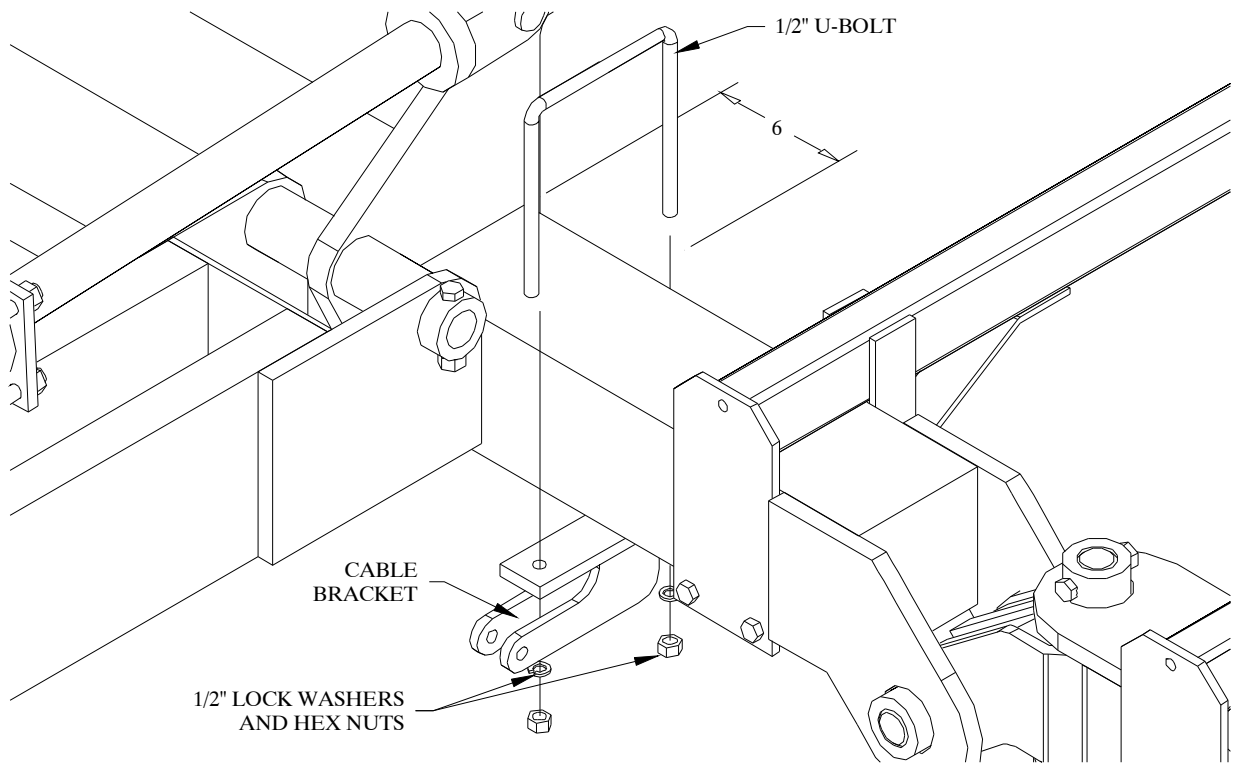


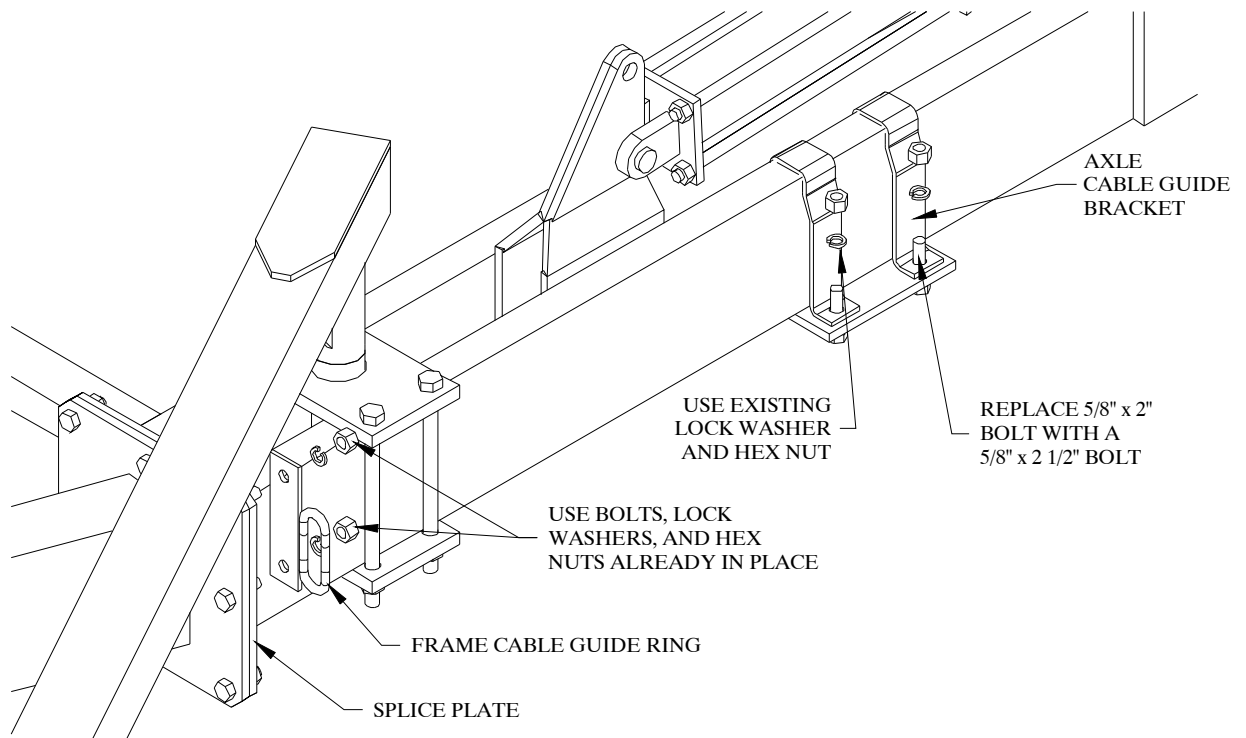
Figure 28

### **Attach the Cable Brackets and Guides**

1. Attach the cable bracket to the center bar 6" from the cylinder hinge plate. Refer to Figure 29. Use two  $\frac{1}{2}$ " x 7" x 8  $\frac{3}{4}$ " u-bolts, lock washers and hex nuts.
2. Attach the frame cable guide ring to the rear side of the frame splice plate as shown in Figure 30. Use the existing top two bolts, lock washers and hex nuts.
3. Attach the axle cable guide brackets to the axle plate as shown in Figure 30. Replace the  $\frac{5}{8}$ " x 2" bolts with  $\frac{5}{8}$ " x 2  $\frac{1}{2}$ " bolts.
4. Repeat on the other side of the cart.



**Figure 29**



**Figure 30**



## Install the Cables

1. Slide a 3/8" cable through the frame cable guide ring and the axle cable guide bracket. Refer to Figure 31.
2. Attach the cable to the bracket on the center bar. Use a 1/2" x 2 1/2" bolt and lock nut and bushing.
3. Connect an 11-link chain to the other end of the cable with a quick-link.
4. Secure the last link of the chain to the lock arm tab with a shackle.
5. Repeat on the other side.

The cables must have slack when in the field position to allow for the center bar to rotate before unlocking the lock bar mechanism. The chain length will be adjusted when assembly is complete.

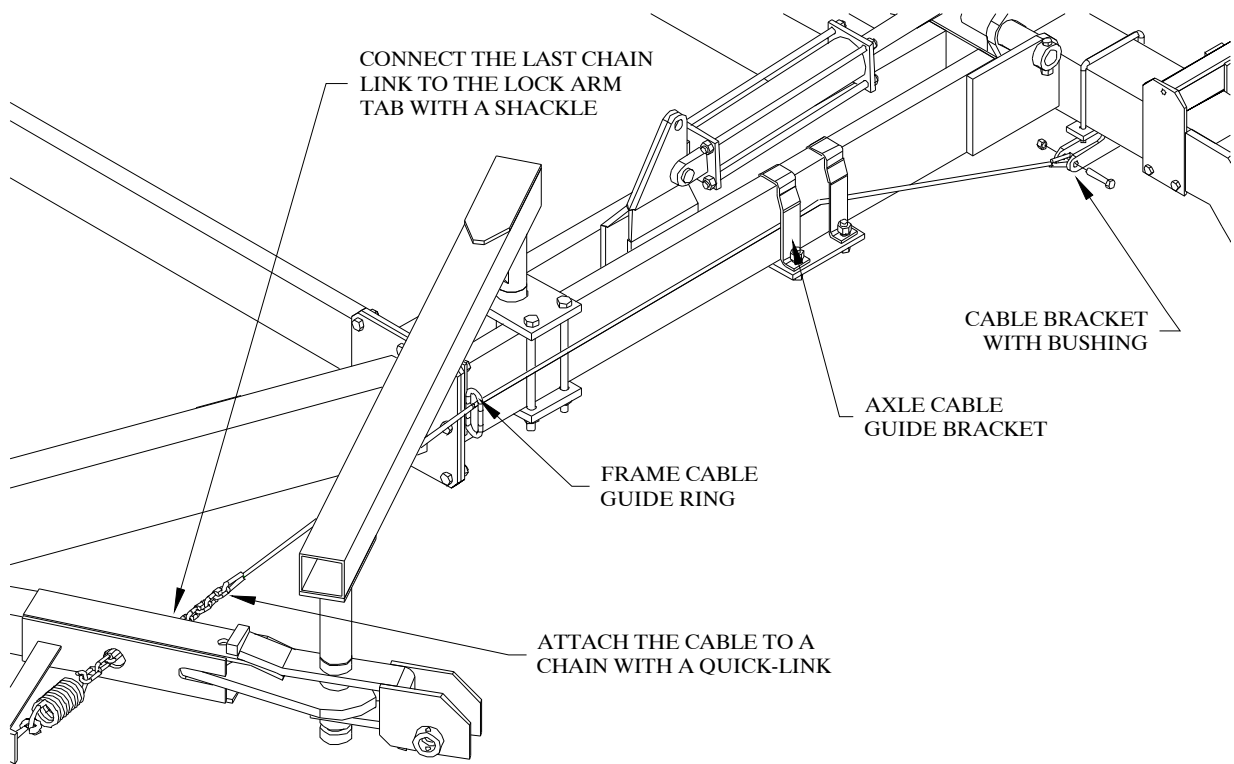


Figure 31

## Attach the Main Pull Tube to the Pivot Bracket

1. Attach the main pull tube to the pivot bracket with the 1 1/2" x 6 1/2" pin. Refer to Figure 32. Note that the grease fitting should be on the end nearest to the cart and pointed up.
2. Lock the pin in place with a 1/2" x 3" bolt and locking hex nut.
3. Repeat on the other side.

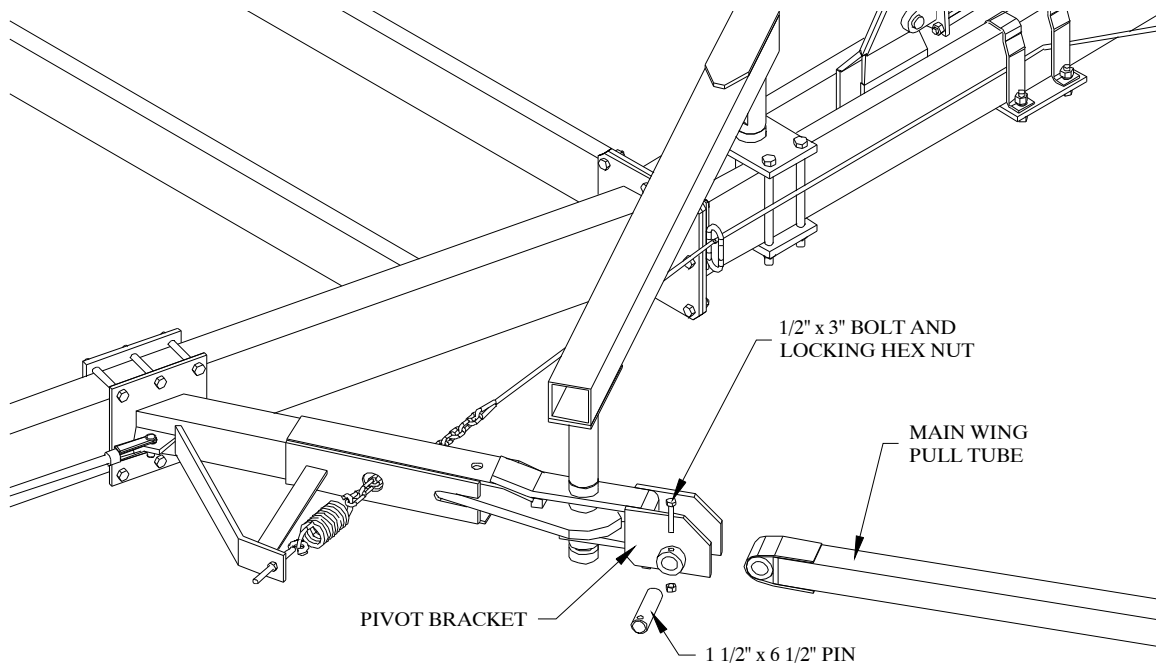


Figure 32

**Attach the Main Pull Tubes to the Wings**

1. Attach the main pull tube anchor assembly to the wing as shown in Figure 33. Be sure the wing is in line with the center bar. Use six 5/8" x 9" bolts, lock washers, hex nuts and a clamp plate. Note: there is a stop tab welded to the wing to prevent the anchor assembly from sliding on the wing.
2. Repeat on the other side.

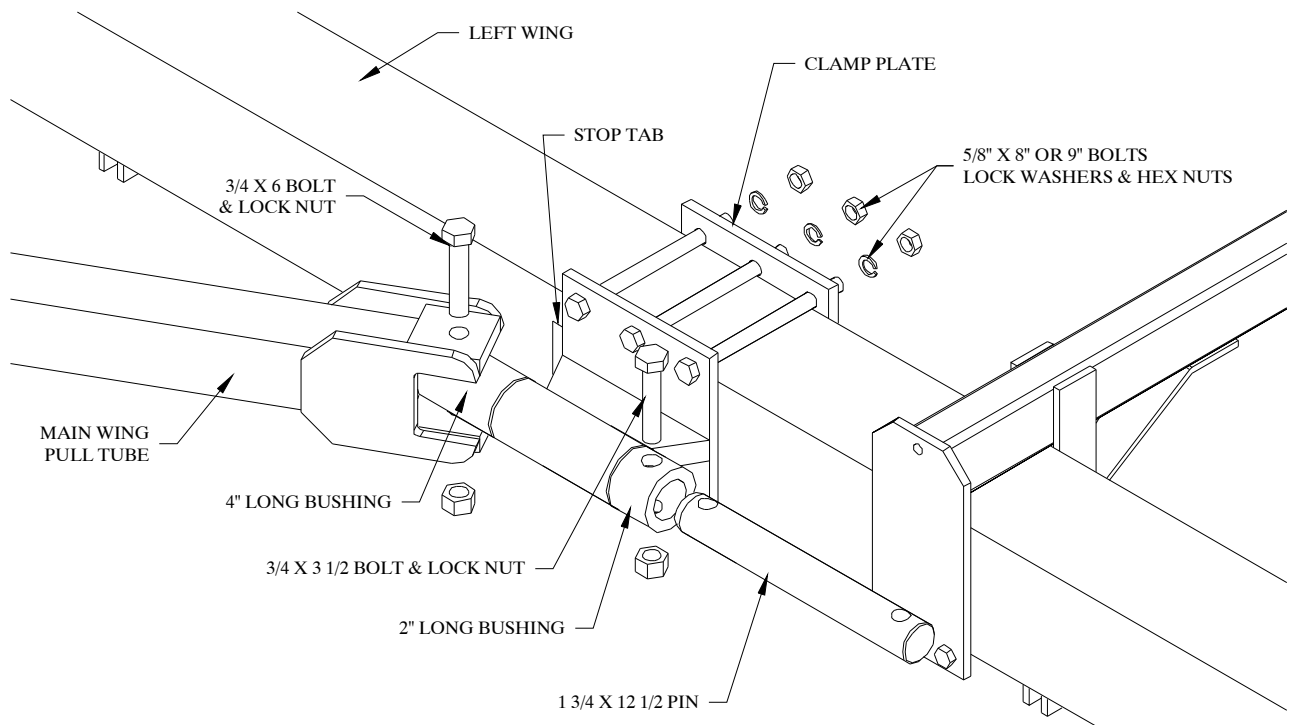


Figure 33

## **Cable Adjustment**

Slowly rotate the center bar into the transport position. Be sure the locks do not release before the lift arms reach about a 45° angle. *If the lock bar unlocks too early in the lifting procedure, the lock will be damaged.*

If the center bar rotates all the way up and the locks do not release, the chains connecting the cables and the lock arms must be shortened. Shorten the chains one link at a time until the lock bars release as soon as the sections have been lifted off the ground (when the lift arm forms about a 45° angle with the ground).

## **Final Adjustments**

1. Check to make sure that all bolts and fasteners are tight.
2. With the unit in the transport position (refer to the operating instructions), attach the red and amber reflectors at the widest visible points. The red reflectors should be visible from the rear of the unit, and the amber reflectors should be visible from the front of the unit.

Do not detach the unit from the tractor unless the unit is in the transport position with jack stands down and the cylinder lock bars in place.

This completes the assembly of your harrow and transport cart. Before using the unit, double check that all components have been assembled properly. If there are any questions regarding any of the assembly steps, contact your local dealer for an explanation. Do not operate this or any equipment unless you are sure that all components operate as they were designed to operate.

## TROUBLESHOOTING

PROBLEM	POSSIBLE CAUSE	SOLUTION
Hydraulics actuate too rapidly	Hydraulic restrictor not installed	Install hydraulic restrictor
Wing(s) not aligned with the center bar	Wing cable bracket(s) improperly positioned	Reposition wing cable bracket(s)
Excessive clogging during operations	Angle of attack too steep	Pull harrow sections from the other end
	Ground speed too low	Increase ground speed to 6 - 9 mph
Pivot arm will not lock securely	Pivot arm improperly positioned	Reposition pivot arm base
	Lock bracket assembly improperly positioned	Reposition pivot arm assembly
	Spring tension inadequate	Tighten spring on lock bracket assembly
Lock mechanism will not release when lift arms are raised completely	Cable/chain assembly is too long	Shorten chain at end of cable (CAUTION: do not overcompensate - damage to lock bracket assembly may occur if chain is too short)

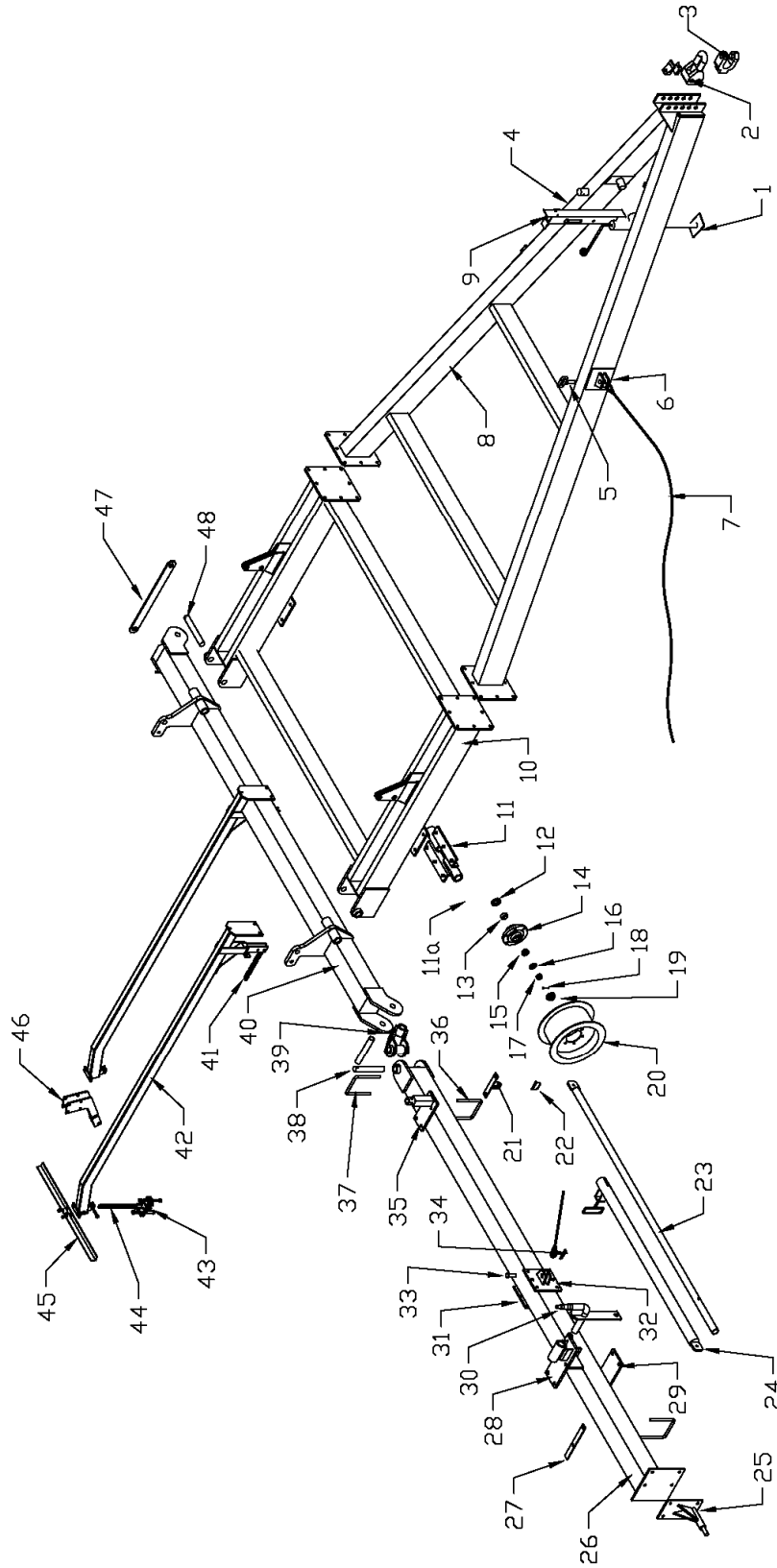
## BOLT TORQUE SPECIFICATIONS

Coarse Thread Series			Fine Thread Series		
Nut Size and Threads per Inch	Nut Tightening Torque (lb.ft.)		Nut Size and Threads per Inch	Nut Tightening Torque (lb.ft.)	
Grade C Nuts			Grade C Nuts		
	Max.	Min.		Max.	Min.
1/4 - 20	14.7	10	1/4 - 28	14.7	10
5/16 - 18	22.3	15.2	5/16 - 24	23.4	18.4
3/8 - 16	39	28	3/8 - 24	41	30
7/16 - 14	60	44	7/16 - 20	60	44
1/2 - 13	88	63	1/2 - 20	98	70
9/16 - 12	134	98	9/16 - 18	134	98
5/8 - 11	172	127	5/8 - 18	176	127
3/4 - 10	295	218	3/4 - 16	295	218
7/8 - 9	440	317	7/8 - 14	440	317
1 - 8	651	506	1 - 14	703	610

## WHEEL LUG TORQUE SPECIFICATIONS

Tire Size	Lug Size	Lug Tightening Torque (lb.ft.)	
		Max.	Min.
18.5X8.5-8	½ nut	85	75
7.60-15	½ x 1	85	75
9.5L-15	½ x 1	90	80
11L-15	½ x 1	90	80
12.5L-15	9/16 x 1	90	80
13X13.5-15	9/16 x 1	90	80
425/65R 22.5	3/4 nut	90	80

# WDL-2070 HARROW CART PARTS DIAGRAM



**WDL-2070 HARROW CART  
PARTS LIST**

Always order by Part Number - *Not* by Key Number

KEY	PART #	DESCRIPTION	QTY.
1	HD-1152	JACK STAND (15")	2
	HD-1151	JACK STAND (10")	1
2	PPI-400	BASE HITCH	1
3	PPI-208	CLEVIS	1
4	RT-3102	HYDRAULIC HOSE RACK	1
5	WDL-2781	WING CABLE PIN	2
6	WDL-2780	#6 BRIDGE (hair) PIN	2
7	WC-2332	WING PULL CABLE	2
8	WDL-2101	WDL A-FRAME	1
9	RT-3104	HYDRAULIC HOSE CLAMP	1
10	WDL-2201	WDL SQUARE FRAME	1
11	WDL-2500	MAIN FRAME AXLE	2
11a	WDL-2505	MAIN FRAME AXLE SPINDLE	4
12	HD-1360	GREASE SEAL (6-hole hub)	8
13	HD-1362	INNER BEARING (6-hole hub)	8
14	HD-1361	HUB WITH RACES (6-hole hub)	8
15	HD-1363	OUTER BEARING (6-hole hub)	8
16	HD-1364	SPINDLE FLAT WASHER (6-hole hub)	8
17	HD-1365	SPINDLE HEX NUT (6-hole hub)	8
18	CP-1517	COTTER PIN	8
19	HD-1367	DUST CAP (6-hole hub)	8
20	HD-1368	RIM (15" x 8" 6-hole) for 11L-15 tire	8
21	WDL-3072	TIE-BAR STOW BRACKET	1
22	WD-144	3/8" x 2 1/2" LYNCH PIN	2
23	WDL-3095	LEFT TIE-BAR HALF	1
24	WDL-3076	RIGHT TIE-BAR HALF	1
25	WDL-2514	WING WHEEL AXLE BRACKET	2
25a	WDL-2505	AXLE SPINDLE	2
26	WDL-2473	WING BAR, RIGHT, 2070	1
**	WDL-2472	WING BAR, RIGHT, OPTIONS, 2070	1
**	WDL-2470	WING BAR, LEFT, 2070	1
**	WDL-2471	WING BAR, LEFT, OPTIONS, 2070	1
27	WDL-3075	WING CABLE STOW BRACKET	2
28	WDL-2556	TRANSPORT AXLE, RIGHT	1
**	WDL-2555	TRANSPORT AXLE, LEFT	1
29	WDL-2517	TRANSPORT AXLE CLAMP PLATE	2
30	WDL-2522	TRANSPORT AXLE SPINDLE ASSEMBLY	2
**	WDL-2523	TRANSPORT AXLE THRUST BEARING 2"	2
**	WDL-2581	TRANSPORT AXLE WASHER	2

31	WDL-2731	WING CABLE BRACKET CLAMP PLATE	2
32	WDL-2730	WING CABLE BRACKET	2
33	HD-1149	1" x 2 1/2" CLEVIS PIN	2
34	CP-3620	3/16" x 2" COTTER PIN	2
35	WDL-2739	WING JACK PLATE	2
36	BU-5878	U-BOLT (5/8" x 7" x 8 1/2")	4
37	BU-1278	U-BOLT (1/2" x 7" x 8 3/4")	3
38	WDL-2736	KNUCKLE HINGE PIN (1 3/4" x 11 1/16")	4
39	WDL-2733	HINGE KNUCKLE	2
40	WDL-2312	CENTER BAR ASSEMBLY	1
41	CH-0808	8-LINK PULL CHAIN	*
42	WDL-2621	8-BAR LIFT ARM	*
43	HDL-5100	DUAL SECTION CONNECTOR LINK	*
44	CH-0808	8-LINK LIFT CHAIN	*
45	HD-3xxx	LIFT ARM STABILIZER ANGLES	*
46	HDL-3300	REAR PULL POINT ASSEMBLY	*
47	SC-600	CYLINDER LOCK BAR	2
48	WDL-2714	CENTER BAR HINGE PIN (1 1/2" x 11 1/16)	2
**	DC-111	DECAL: "STAND CLEAR..."	1
**	DC-116	DECAL: "DO NOT CLIMB ON..."	1
**	DC-117	DECAL: "...USE JACK STAND"	1
**	DC-119	DECAL: "ESCAPING FLUID..."	1
**	LIT-0420	LITERATURE PACKET	1

\* Quantity depends on harrow sections used.

\*\* Unnumbered items are not pictured.

\*\*\* Please specify model number when ordering these parts.

xxx length in inches (84" is 084, 112" is 112)

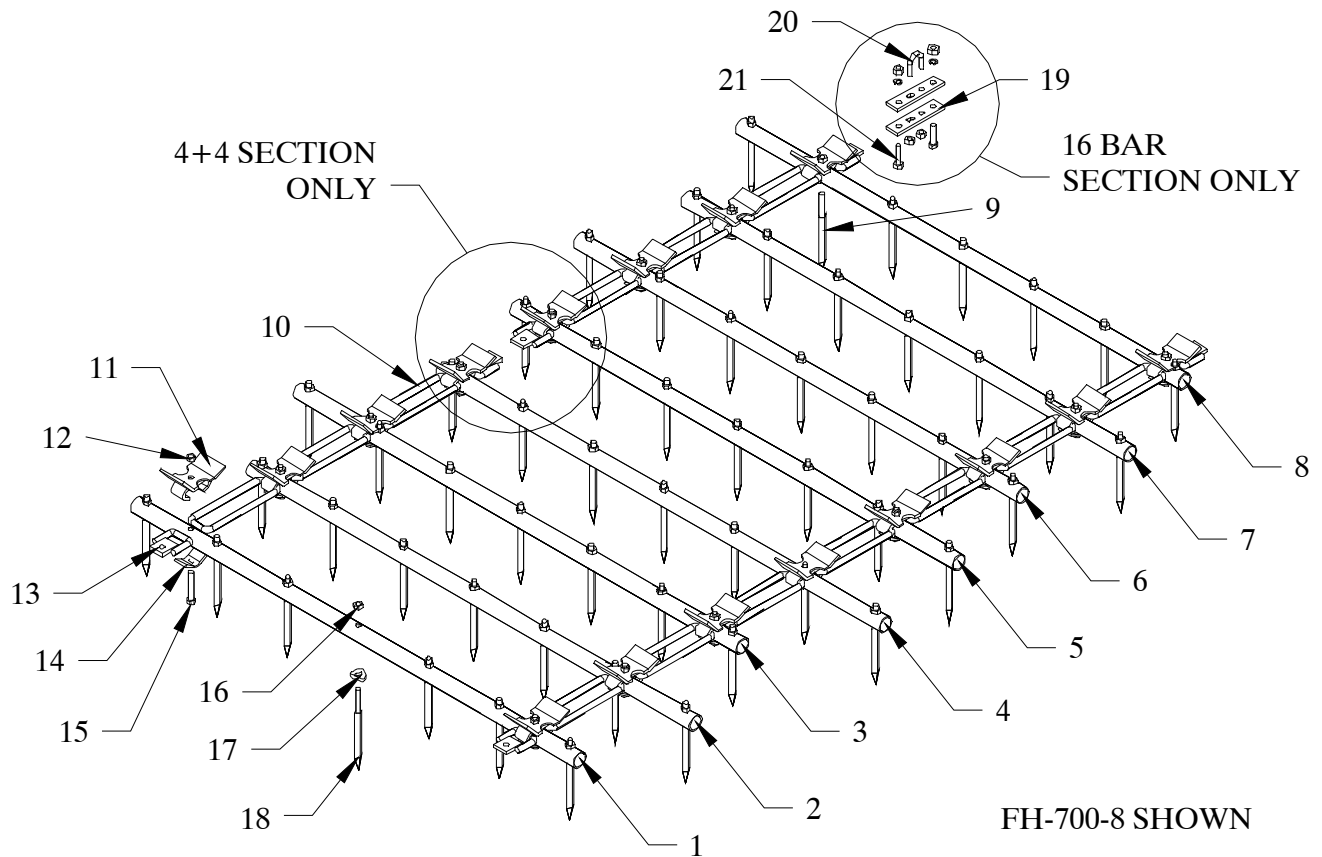
Bolts, washers, nuts, and cotter pins are not shown. Refer to the step-by-step assembly instructions for details.

**McFarlane Manufacturing reserves the right to change specifications of design at any time without obligation to modify previous products.**



## FH-8-BAR HARROW SECTIONS PARTS DIAGRAM & LISTING

INCLUDES FH-500-8, FH-600-8, FH-700-8, FH-800-8, AND FH-900-8



ITEM #	PART #	DESCRIPTION
1	FH-801	#1 HARROW BAR (FH-500-8)
1	FH-805	#1 HARROW BAR (FH-600-8)
1	FH-809	#1 HARROW BAR (FH-700-8)
1	FH-813	#1 HARROW BAR (FH-800-8)
1	FH-817	#1 HARROW BAR (FH-900-8)
2	FH-802	#2 HARROW BAR (FH-500-8)
2	FH-806	#2 HARROW BAR (FH-600-8)
2	FH-810	#2 HARROW BAR (FH-700-8)
2	FH-814	#2 HARROW BAR (FH-800-8)
2	FH-818	#2 HARROW BAR (FH-900-8)
3	FH-802	#3 HARROW BAR (FH-500-8)
3	FH-806	#3 HARROW BAR (FH-600-8)
3	FH-810	#3 HARROW BAR (FH-700-8)
3	FH-814	#3 HARROW BAR (FH-800-8)
3	FH-818	#3 HARROW BAR (FH-900-8)
4	FH-804	#4 HARROW BAR (FH-500-8)
4	FH-808	#4 HARROW BAR (FH-600-8)
4	FH-812	#4 HARROW BAR (FH-700-8)
4	FH-816	#4 HARROW BAR (FH-800-8)

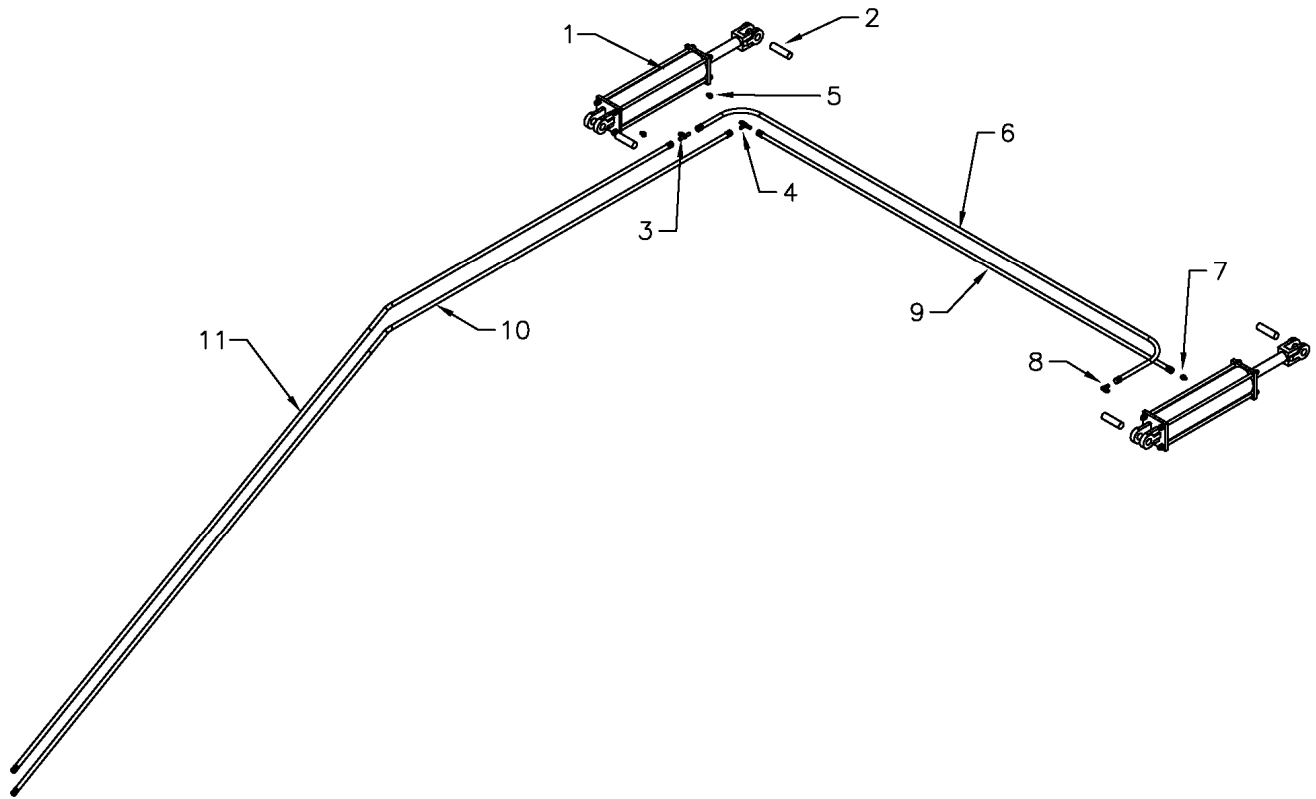
4	FH-820	#4 HARROW BAR (FH-900-8)
5	FH-803	#5 HARROW BAR (FH-500-8)
5	FH-807	#5 HARROW BAR (FH-600-8)
5	FH-811	#5 HARROW BAR (FH-700-8)
5	FH-815	#5 HARROW BAR (FH-800-8)
5	FH-819	#5 HARROW BAR (FH-900-8)
6	FH-803	#6 HARROW BAR (FH-500-8)
6	FH-807	#6 HARROW BAR (FH-600-8)
6	FH-811	#6 HARROW BAR (FH-700-8)
6	FH-815	#6 HARROW BAR (FH-800-8)
6	FH-819	#6 HARROW BAR (FH-900-8)
7	FH-801	#7 HARROW BAR (FH-500-8)
7	FH-805	#7 HARROW BAR (FH-600-8)
7	FH-809	#7 HARROW BAR (FH-700-8)
7	FH-813	#7 HARROW BAR (FH-800-8)
7	FH-817	#7 HARROW BAR (FH-900-8)
8	FH-804	#8 HARROW BAR (FH-500-8)
8	FH-808	#8 HARROW BAR (FH-600-8)
8	FH-812	#8 HARROW BAR (FH-700-8)
8	FH-816	#8 HARROW BAR (FH-800-8)
8	FH-820	#8 HARROW BAR (FH-900-8)
9	E-611	1/2" x 3" SHANK SPIKE TOOTH ONLY
10	FH-125	CONNECTOR LINK (REGULAR)
11	FH-127	NOTCHED LINK CAP
12	**	1/2" LOCK NUT
13	FH-122	PULL FLAT
14	FH-019	CAP CLIP
15	**	1/2" x 3" BOLT
16	**	1/2" FLANGED LOCK NUT
17	E-630	SPIKE TOOTH WASHER
18	E-620	1/2" x 2 1/2" SHANK SPIKE TOOTH ONLY
**	E-610	1/2" x 2 1/2" SHANK SPIKE TOOTH w/WASHER
19	HDL-5100	DUAL SECTION CONNECTOR FLAT (16 BAR ONLY)
20	BV-7611	7/16" V-BOLT (16 BAR ONLY)
21	**	1/2" x 2" BOLT, LOCK WASHER AND NUT (16 BAR ONLY)
**	HDL-5101	DUAL SECTION CONNECTOR ASSEMBLY (16 BAR ONLY)

The #1 bar is the bar with an equal amount of tube to the right and left of the pull flats. The #8 bar is the bar that is staggered off to one side.

When pulling the harrow section from the #1 bar, the teeth will be in the least aggressive setting. When pulling from the #8 bar the teeth will be in the most aggressive setting.

9/24/08

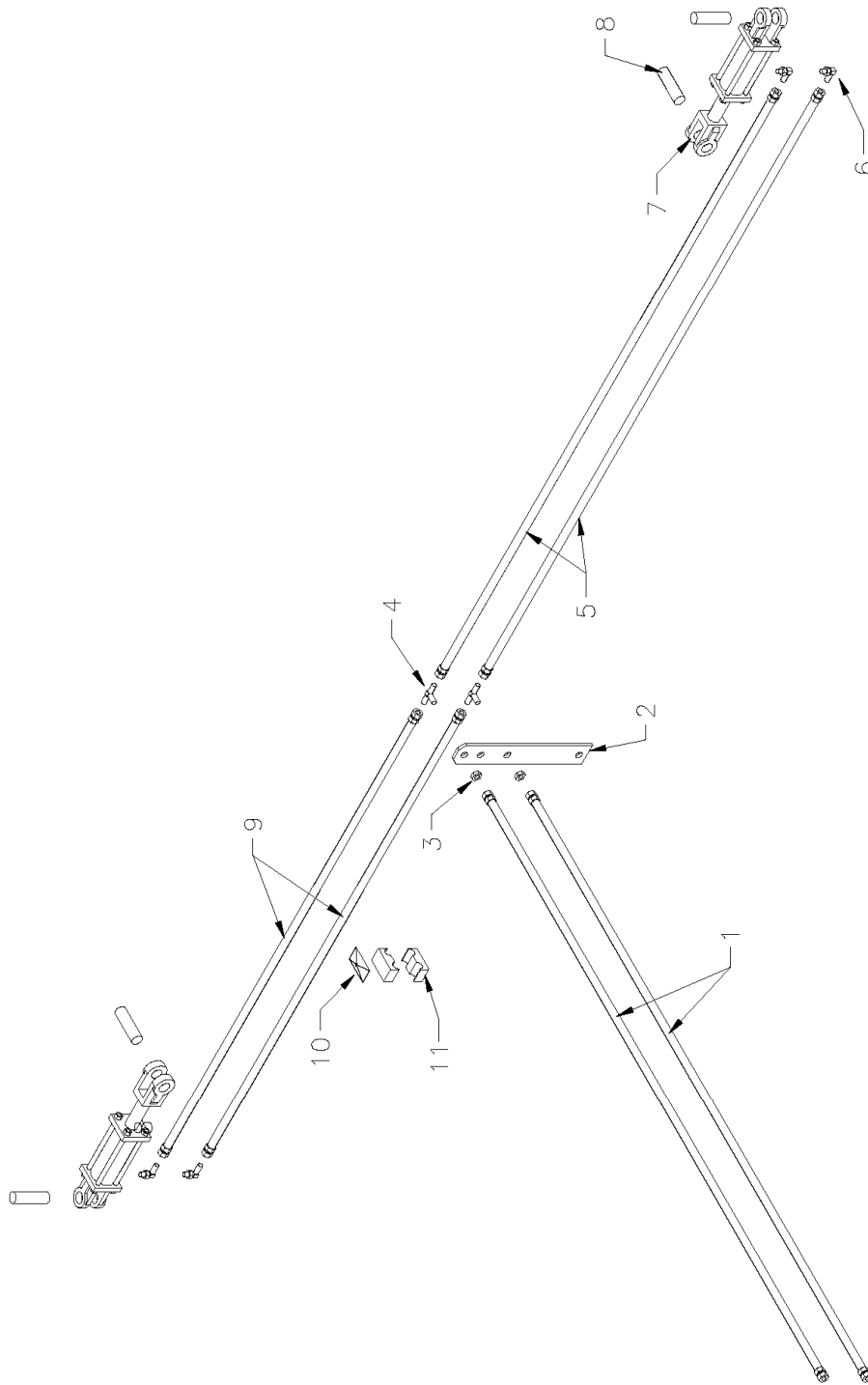
## WDL-2070 HARROW CART HYDRAULICS PARTS LIST



KEY	PART #	DESCRIPTION	QTY.
1	HYA-35016	ASAE 5" x 16" HYDRAULIC CYLINDER	2
2	SC-503	1 1/4" x 6 3/4" CLEVIS PIN	4
3	HYF-1808	TEE (3/8"m - 3/8"o-ring - 3/8"m)	1
4	HYF-1088	TEE (3/8"o-ring - 3/8"m - 3/8"m)	1
5	HYF-3301	ADAPTER (3/8"o-ring - 1/2"o-ring)	2
6	HYH-8126	3/8" x 126" HYDRAULIC HOSE	1
7	HYF-3820	ADAPTER (3/8"f - 1/2"o-ring)	1
8	HYF-2820	ELBOW (3/8"f - 1/2"o-ring)	1
9	HYH-8090	3/8" x 90" HYDRAULIC HOSE	1
10	HYH-7300	3/8" x 300" HYDRAULIC HOSE w/one 1/2" end	1
11	HYH-9265	3/8" x 265" HYDRAULIC HOSE w/restrictor & 1/2" end	1

Note: When ordering cylinder replacement parts, please specify cylinder make & part number.  
**McFarlane Manufacturing reserves the right to change specifications of design at any time without obligation to modify previous products.**

# HYDRAULIC TRANSPORT WHEEL OPTION PARTS DIAGRAM



**HYDRAULIC TRANSPORT WHEEL OPTION  
PARTS LIST**

Always order by Part Number - *Not* by Key Number

KEY	PART #	DESCRIPTION	QTY.
1	HYH-9326	3/8" x 326" HYDRAULIC HOSE (w/one 1/2" pipe end)	2
2	WDL-2307	HYDRAULIC TEE POST	1
**	BU-1278	1/2" X 7" X 8 3/4" U-BOLT	1
3	HYO-4000	3/8" HYDRAULIC TEE NUT	2
4	HYF-1888	TEE (3/8"m – 3/8"m – 3/8"m)	2
5	HYH-8400	3/8" x 400" HYDRAULIC HOSE (WDL-2070 only)	2
6	HYF-2820	ELBOW (3/8"f – 1/2"o-ring)	4
7	HYC-32004	2" x 4" HYDRAULIC CYLINDER	2
8	HYO-2103	1" x 3 - 1/2" CLEVIS PIN	4
9	HYH-8330	3/8" x 330" HYDRAULIC HOSE (WDL-2070 only)	2
10	HYH-1004	3/8" HYDRAULIC HOSE CLAMP COVER	4
11	HYH-1002	3/8" HYDRAULIC HOSE CLAMP BODY	7
**	BB-0492	BOLT BAG	1
**	HY-0492	HYDRAULIC BAG (WDL-2070 only)	1
**	MM-1200	BAG OF TIES	1
**	***	LITERATURE PACKET	1

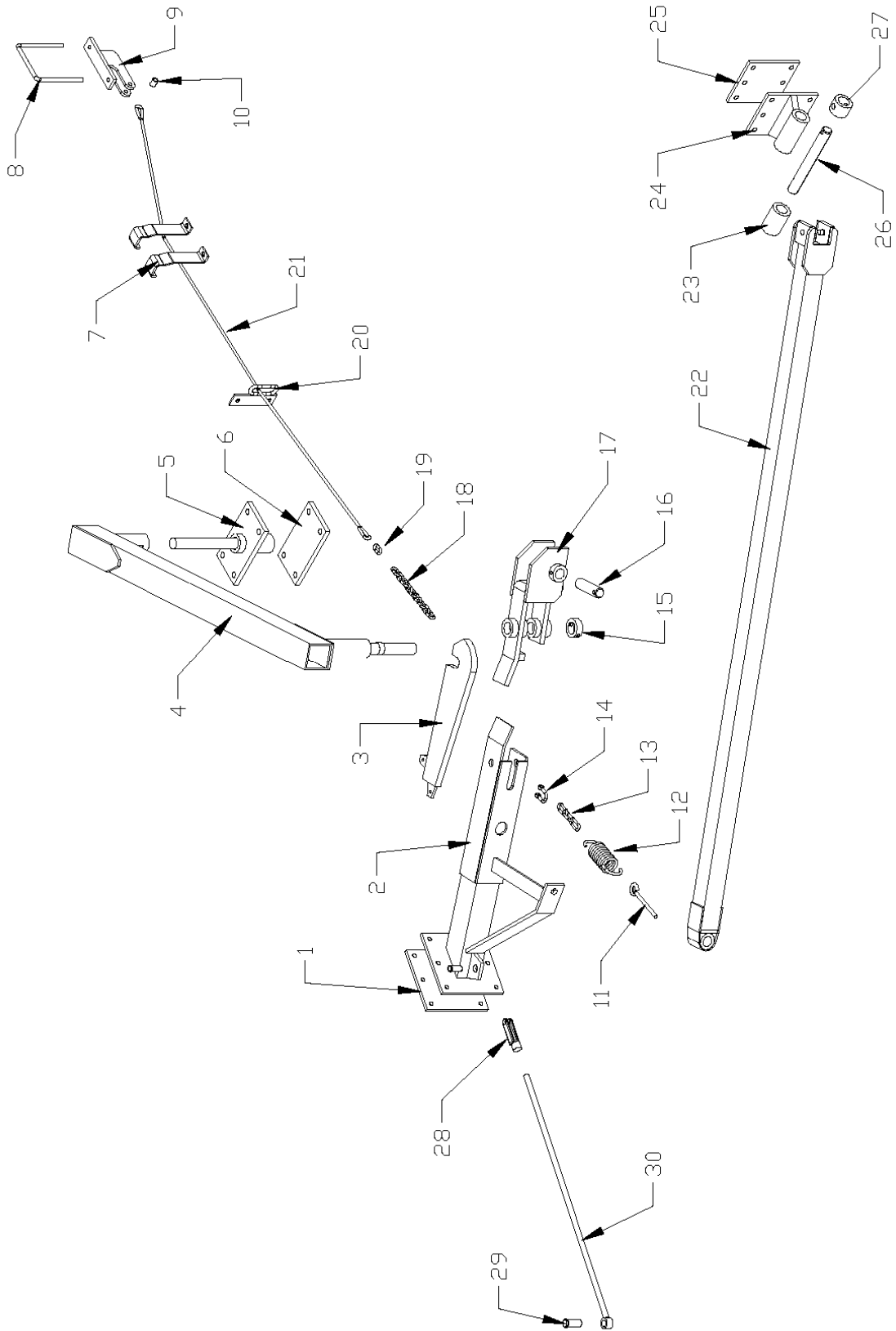
\*\* Unnumbered items are not pictured.

\*\*\* Please specify model number when ordering these parts.

Bolts, washers, and nuts are not shown. Refer to the step-by-step assembly instructions for details.

**McFarlane Manufacturing reserves the right to change specifications of design at any time without obligation to modify previous products.**

# AUTO-BACKUP WING PULL-TUBE OPTION PARTS DIAGRAM



**AUTO-BACKUP WING PULL-TUBE OPTION  
PARTS LIST**

Always order by Part Number - *Not* by Key Number

KEY	PART #	DESCRIPTION	QTY.
1	WD-2912	LOCK BRACKET ASSEMBLY CLAMP PLATE	2
2	WD-2920	LEFT LOCK BRACKET ASSEMBLY	1
**	WD-2921	RIGHT LOCK BRACKET ASSEMBLY	1
3	WD-2922	LOCK ARM	2
4	WD-2901	PIVOT ARM ASSEMBLY	2
5	WD-2904	PIVOT ARM BASE	2
6	WD-2914	PIVOT ARM BASE CLAMP PLATE	2
7	WD-2924	AXLE CABLE GUIDE BRACKET	4
8	BU-1267	U-BOLT (1/2 X 6 X 7 3/4) (WDL-2045 through 2060 only)	2
**	BU-1278	U-BOLT (1/2 X 7 X 8 3/4) (WDL-2070 only)	2
9	WD-2909	CABLE BRACKET (WDL-2045 through 2060 only)	2
**	WD-2929	CABLE BRACKET (WDL-2070 only)	2
10	HD-1216	BUSHING	2
11	HDL-2534	EYE BOLT	2
12	RBH-0308	SPRING	2
13	CH-0703	3-LINK CHAIN	2
14	AL-030	SHACKLE	4
15	WD-2911	LOCK COLLAR	2
16	WD-2915	TUBE CONNECTOR PIN	2
17	WD-2905	WING PULL TUBE CONNECTOR	2
18	CH-0607	7-LINK CHAIN	2
19	WD-181	QUICK LINK	2
20	WD-2908	FRAME CABLE GUIDE RING	2
21	WC-8105	CABLE	2
22	***	MAIN PULL TUBE	2
23	WD-2926	WING ANCHOR LONG BUSHING	2
24	WD-2906	WING ANCHOR (WDL-2045 through 2060 only)	2
**	WD-2946	WING ANCHOR (WDL-2070 only)	2
25	WDL-2711	WING ANCHOR CLAMP PLATE (2045 through 2060 only)	2
**	WDL-2731	WING ANCHOR CLAMP PLATE (WDL-2070 only)	2
26	WD-2916	WING ANCHOR PIN	2
27	WD-2936	WING ANCHOR SHORT BUSHING	2
28	WD-2918	3/4 X 6 YOKE	2
29	HD-1149	1 X 2 1/2 CLEVIS PIN & 3/16 X 2 COTTER PIN	2
30	WD-2917	ADJUSTER ROD	2
**	BB-0470	BOLT BAG (WDL-2045 through 2060 only)	1
**	BB-0475	BOLT BAG (WDL-2070 only)	1
**	***	LITERATURE PACKET	1

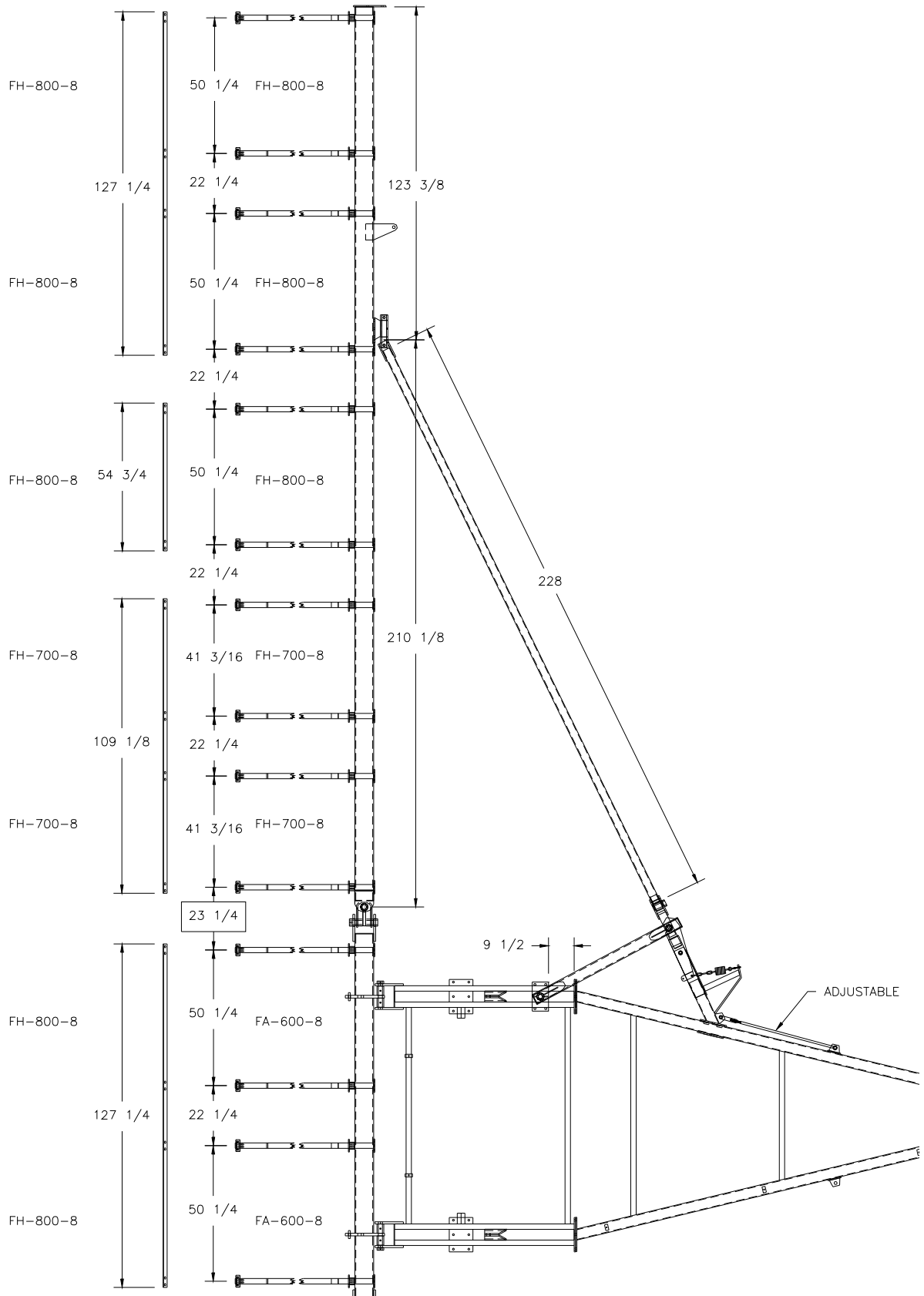
\*\* Unnumbered items are not pictured.

\*\*\* Please specify model number when ordering these parts.

Bolts, washers, and nuts are not shown. Refer to the step-by-step assembly instructions for details.

**McFarlane Manufacturing reserves the right to change specifications of design at any time without obligation to modify previous products.**

# WDL-2070 HARROW CART LAYOUT DIAGRAM





## WARRANTY REGISTRATION FORM

This form must be filled out by the dealer and owner and sent to: McFarlane Mfg. Co., Inc.,  
1330 Dallas Street, P.O. Box 100, Sauk City, WI 53583.

### WARRANTY REGISTRATION FORM & INSPECTION REPORT

#### WARRANTY REGISTRATION

This form must be filled out by the dealer and signed by both the dealer and customer at the time of delivery.

Customer Name \_\_\_\_\_ Dealer Name \_\_\_\_\_

Address \_\_\_\_\_ Address \_\_\_\_\_

City, state, code \_\_\_\_\_ City, state, code \_\_\_\_\_

Phone number (\_\_\_\_) \_\_\_\_\_

Model \_\_\_\_\_ Serial Number \_\_\_\_\_ Delivery Date \_\_\_\_\_

#### DEALER INSPECTION REPORT

- \_\_\_\_\_ Wheel bolts tight
- \_\_\_\_\_ Fasteners tight
- \_\_\_\_\_ Hydraulic hoses free
- \_\_\_\_\_ Hydraulic fittings tight
- \_\_\_\_\_ Arms free
- \_\_\_\_\_ Check tire pressures
- \_\_\_\_\_ Lubricate machine

#### SAFETY

- \_\_\_\_\_ All decals installed
- \_\_\_\_\_ Review operating and safety instructions

I have thoroughly instructed the buyer on the above described equipment; review included the operator's manual content, equipment care, adjustments, safe operation and applicable warranty policy.

Date \_\_\_\_\_ Dealer's signature \_\_\_\_\_

The above equipment and operator's manual have been received by me and I have been thoroughly instructed as to care adjustments, safe operation, and applicable warranty policy.

Date \_\_\_\_\_ Owner's signature \_\_\_\_\_