

TA-25 LOADER TOWER REPLACEMENT PARTS

REF #	PART #	DESCRIPTION	QTY.
1	RT-12AS - R	TOWER (RIGHT)	1
2	RT-12AS - L	TOWER (LEFT)	1
3	RT-15AS	SHOE	2
4	RT-20AS - R	SLIDE LOCK (RIGHT)	1
5	RT-20AS - L	SLIDE LOCK (LEFT)	1
6	RT-5	LATCH	2
7	RT-27	LATCH RIVOT	2
8	OH004	FRONT WRAP	*
9	MT-232	WASHER	2
10	QC-806	WASHER	2

REF #	PART #	DESCRIPTION	QTY.
11	HHS1011028	5/8" X 1 3/4" BOLT	4
12	CBF1011072	5/8" X 4 1/2" CARRIAGE BOLT	4
13	CBF1210080	3/4" X 5" CARRIAGE BOLT	4
14	AHS0813010	1/2" X 5/8" SET SCREW	4
15	AHS0813016	1/2" X 1" SET SCREW	2
16	LWM10	5/8" LOCK WASHER	4
17	HTN1011	5/8" LOCK NUT	4
18	HTN1210	3/4" LOCK NUT	4
19	FWW12	3/4" FLAT WASHER	2

*NOTE: *Varies by Tractor (Standard Front Wrap is OH004)*

WESTENDORFMFG PWB017221

WESTENDORF MFG CO., INC. • PH: (712) 423-2762 • FAX: (712) 423-1460 • sales@westendorfmfg.com • www.loaders.com

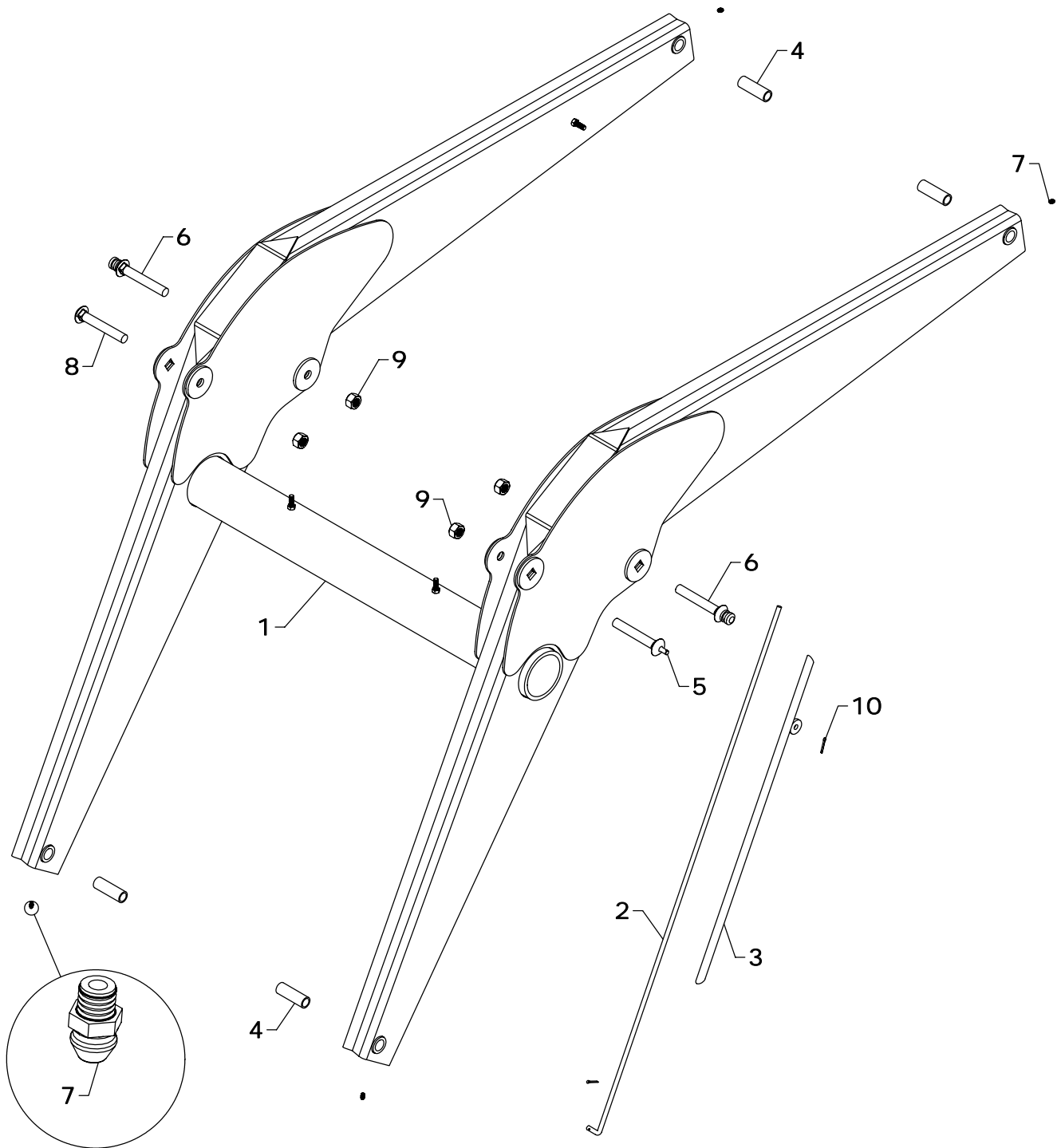

TA-25 LOADER FRAME REPLACEMENT PARTS

REF #	PART #	DESCRIPTION	QTY.
1	RF-4AS	FRAME	1
2	RF-49	INNER GAUGE ROD	1
3	MF-50AS	GAUGE ROD HOLDER	1
4	B-930	INSERT BUSHING	4
5	RF-69AS	GAUGE ROD PIN	1

REF #	PART #	DESCRIPTION	QTY.
6	LF-85AS	LIFT PIN	2
7	ZER1805	GREASE FITTING	4
8	CBF1210080	3/4" X 5" CARRIAGE BOLT	1
9	HTN1210	3/4" LOCK NUT	4
10	CTK0200016	1/8" X 1" COTTER KEY	2

WESTENDORFMFG PWB017221

WESTENDORF MFG. CO., INC. • PH:(712) 423-2762 • FAX: (712) 423-1460 • sales@westendorfmfg.com • www.loaders.com

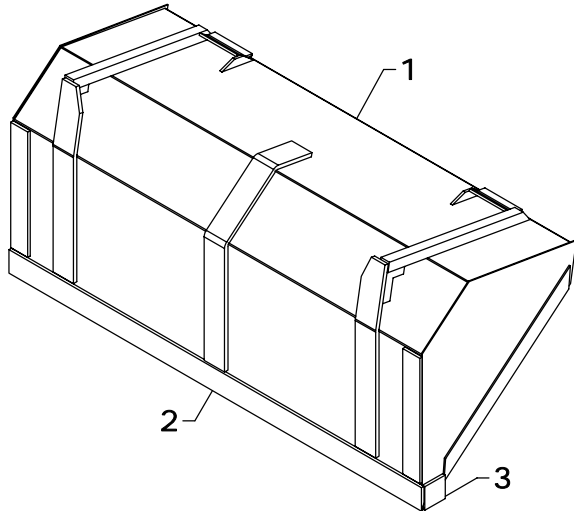

BUCKET

REF #	PART #	DESCRIPTION	QTY.
1	60Q512	60" BUCKET	1
	72Q514	72" BUCKET	1
	66QS14	66" SKID STEER BUCKET	1
	72QS15	72" SKID STEER BUCKET	1
2	MB-114	60" BLADE	1
	IB-14	66" BLADE	1
	JB-14	72" BLADE	1
3	MB-115	SIDE BLADE	2

*NOTE: *Check width of the bucket and use the part number that matches. If your size is not shown, contact Westendorf Mfg. Co.*

COUPLER (C-9)

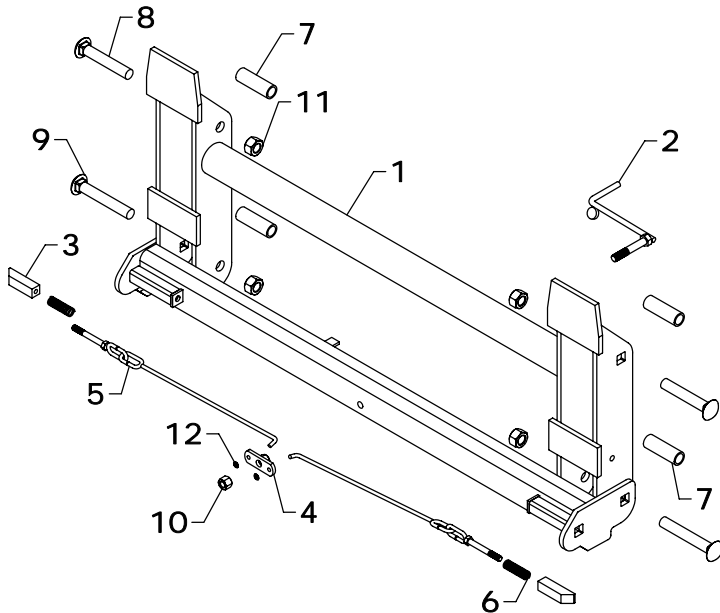

C-9			
REF #	PART #	DESCRIPTION	QTY.
1	QC-901AS	COUPLER	1
2	QC-911AS	HANDLE	1
3	QC-914	BAR CATCH	2
4	QC-915AS	LOCK PIVOT PLATE	1
5	QC-917AS	LATCH ROD	2
6	QC-920	SPRING	2
7	B-930	INSERT BUSHING	4
8	CBF1210072	3/4" X 4 1/2" CARRIAGE BOLT	2
9	CBF1210080	3/4" X 5" CARRIAGE BOLT	2
10	HTN0813	1/2" LOCK NUT	1
11	HFN1210	3/4" NUT	4
12	SR-E02	RETAINING RING	2

NOTE: Order part number QC-901COM if complete coupler is needed.

OPTIONAL SKID STEER COUPLER

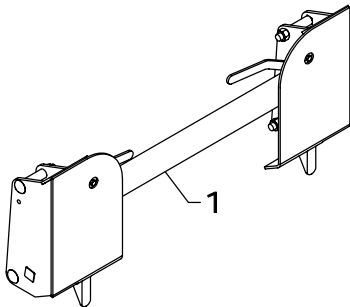

REF #	PART #	DESCRIPTION	QTY.
1	C-20	COUPLER	1

COSMETICS

REF #	PART #	DESCRIPTION	QTY.
1	DEC-25	DECAL KIT	1
2	V-9524-A	BLACK SPRAY PAINT	1
3	V-9524-P	PINT BLACK PAINT	1

REF #	PART #	DESCRIPTION	QTY.
4	V-9524-Q	QUART BLACK PAINT	1
5	V-9524-G	GALLON BLACK PAINT	1

WESTENDORFMFG PWB017221

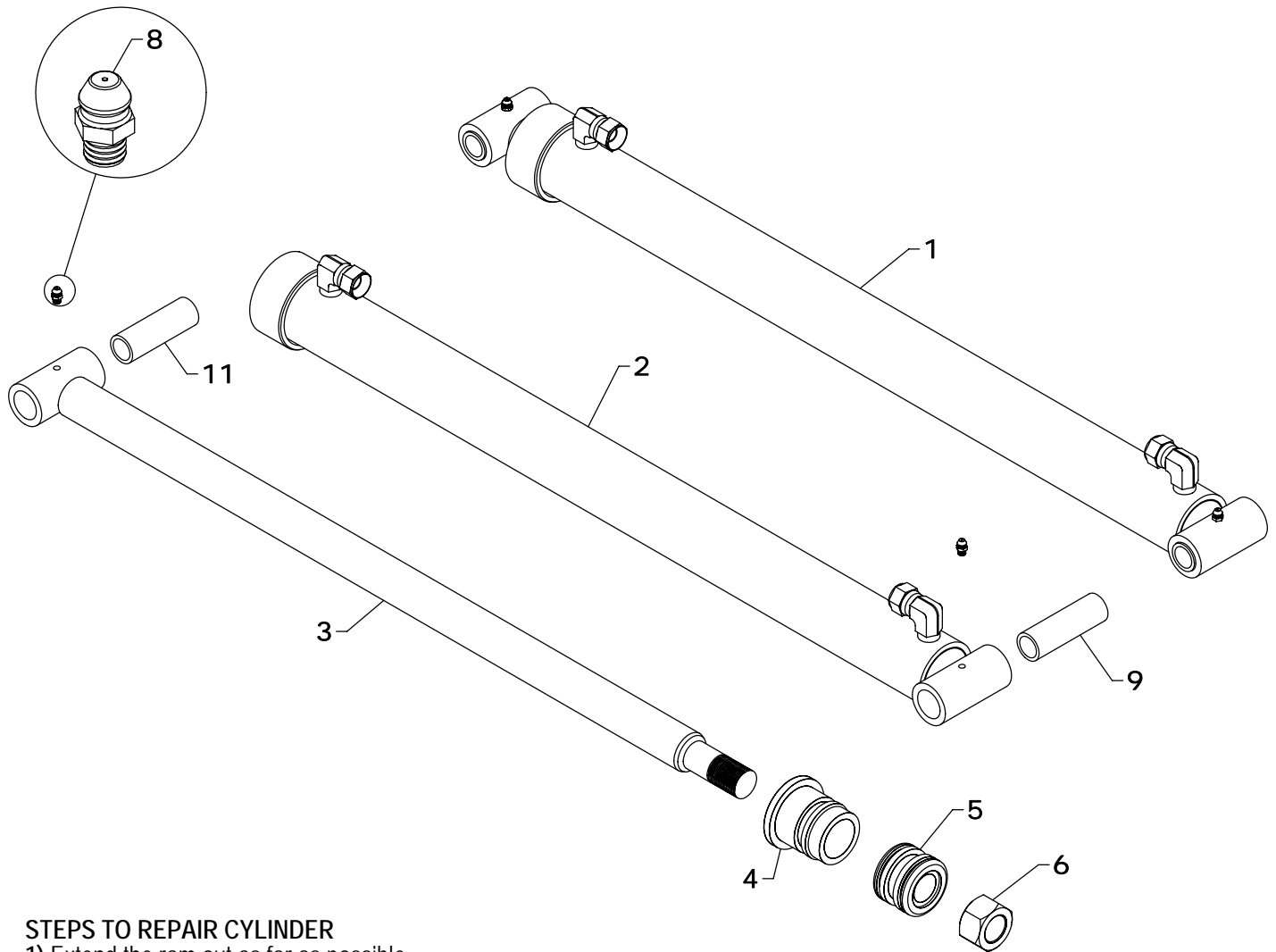

STEPS TO REPAIR CYLINDER

- 1) Extend the ram out as far as possible.
- 2) At the ram end of the cylinder barrel you will find a snap ring located either on the face or inside the notch of the gland.
- 3) Locate the snap ring eyes (you may need to turn the gland inside the barrel to find the snap ring eyes). Compress the snap ring with snap ring pliers.
- 4) Remove the ram assembly (ram, gland, & piston) from barrel.
- 5) Notice the direction they're pointing so they can be properly re-assembled.
- 6) Remove the jam nut and/or hex nut from the end of the ram.
- 7) Remove the old seals and rings and replace them with the new seals and rings. (Seal kits are packaged for several different cylinders. You may have extra parts)
- 8) Clean cylinder with cleaner and a clean lint free cloth.
- 9) Lubricate the seals and rings to aid assembly.
- 10) Assemble the cylinder by reversing the order.

CYLINDER REPAIR TIPS

- When disassembling cylinders, keep the parts in correct orientation. Remove parts in sequence.
- Note the direction of the piston and gland. Lay out old seals and parts as they are removed.
- Assemble cylinder in proper order; lubricate to aid assembly.

BUCKET CYLINDER REPLACEMENT PARTS

REF #	PART #	DESCRIPTION	QTY.
1	B-9	BUCKET CYLINDER	1
2	B-901	BARREL	1
3	B-910	RAM	1
4	G-H	GLAND	1
5	P-C	PISTON	1
6	HFN1614	1" NUT	1
8	ZER1805	GREASE FITTING	2
9	B-931	INSERT BUSHING	1
10	#7CK	REPAIR KIT	*
11	B-930	INSERT BUSHING	1

*NOTE: * Repair kit contains parts to repair one cylinder*

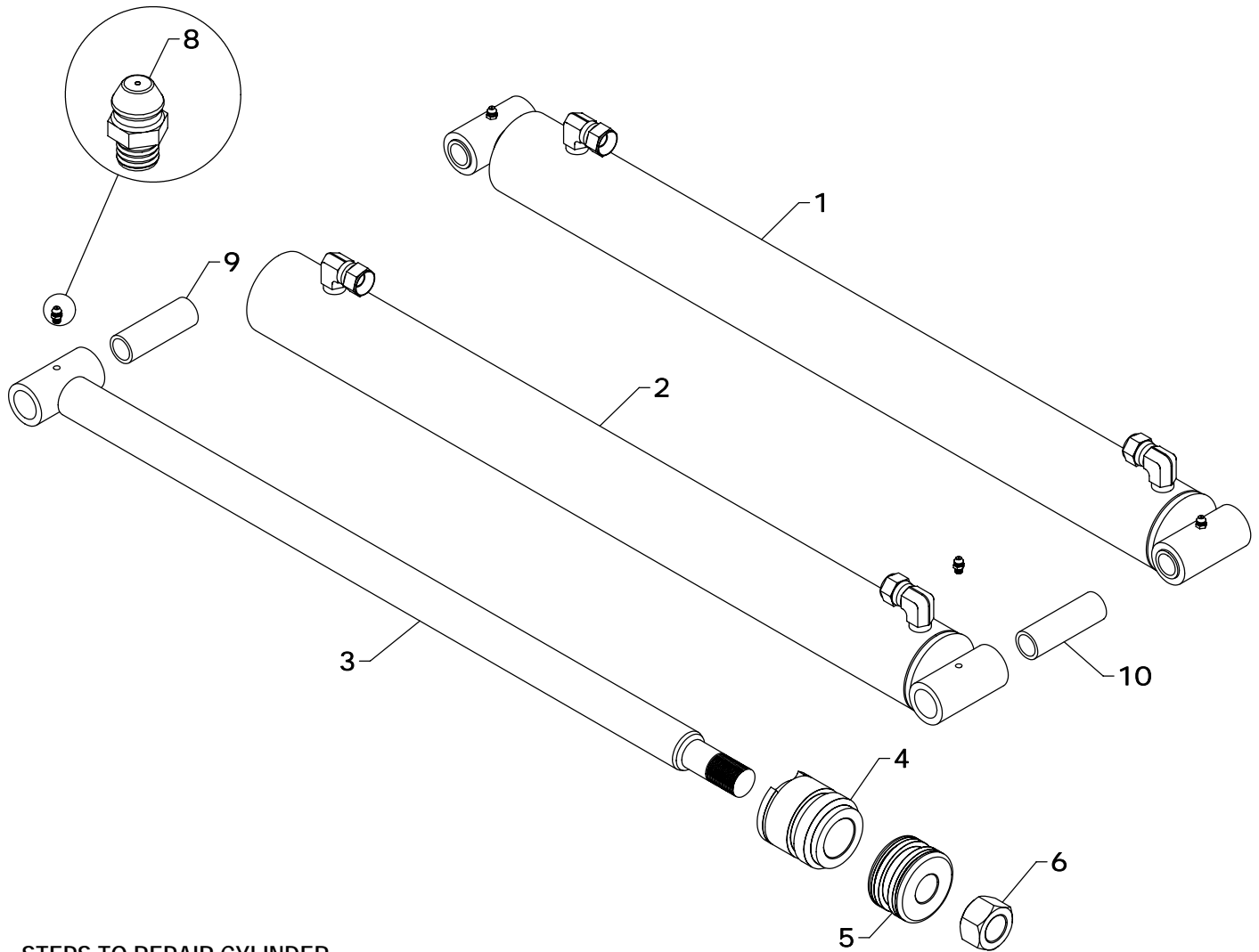

STEPS TO REPAIR CYLINDER

- 1) Extend the ram out as far as possible.
- 2) At the ram end of the cylinder barrel you will find a snap ring located either on the face or inside the notch of the gland.
- 3) Locate the snap ring eyes (you may need to turn the gland inside the barrel to find the snap ring eyes). Compress the snap ring with snap ring pliers.
- 4) Remove the ram assembly (ram, gland, & piston) from barrel.
- 5) Notice the direction they're pointing so they can be properly re-assembled.
- 6) Remove the jam nut and/or hex nut from the end of the ram.
- 7) Remove the old seals and rings and replace them with the new seals and rings. (Seal kits are packaged for several different cylinders. You may have extra parts)
- 8) Clean cylinder with cleaner and a clean lint free cloth.
- 9) Lubricate the seals and rings to aid assembly.
- 10) Assemble the cylinder by reversing the order.

CYLINDER REPAIR TIPS

- When disassembling cylinders, keep the parts in correct orientation. Remove parts in sequence.
- Note the direction of the piston and gland. Lay out old seals and parts as they are removed.
- Assemble cylinder in proper order; lubricate to aid assembly.

LIFT CYLINDER REPLACEMENT PARTS

REF #	PART #	DESCRIPTION	QTY.
1	L-23	LIFT CYLINDER	1
2	L-2301	BARREL	1
3	B-910	RAM	1
4	G-A	GLAND	1
5	P-A	PISTON	1
6	HFN1614	1" NUT	1
8	ZER1805	GREASE FITTING	2
9	B-930	INSERT BUSHING	1
10	B-931	INSERT BUSHING	1
11	#1CK	REPAIR KIT	*

*NOTE: * Repair kit contains parts to repair one cylinder*

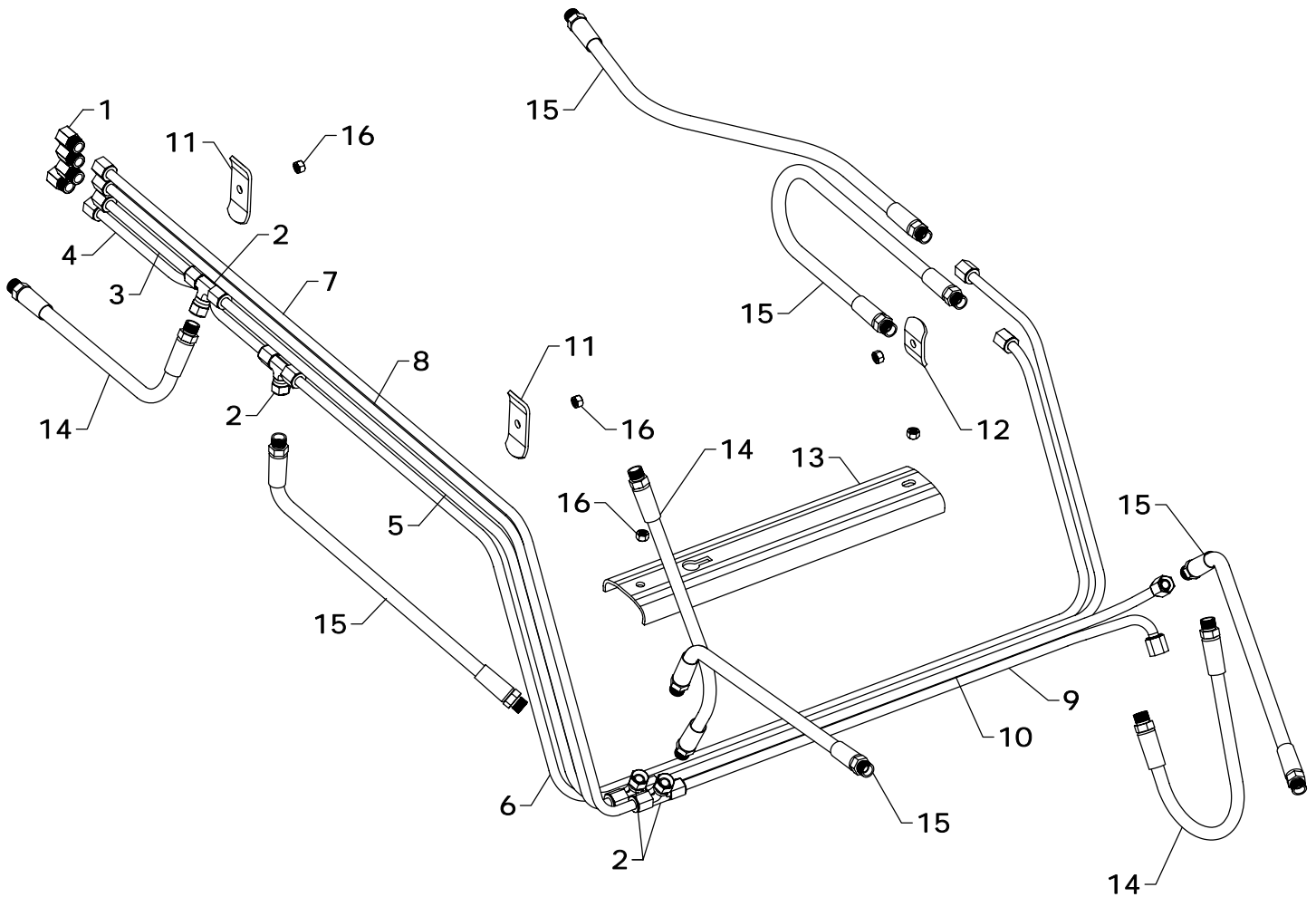

TA-25 HYDRAULICS

REF #	PART #	DESCRIPTION	QTY.
1	PF-FFC8	FEMALE CONNECTOR	4
2	PF-FSBT8	SWIVEL NUT TEE	4
3	OLT-128	OIL LINE	1
4	OLT-129	OIL LINE	1
5	OLT-130	OIL LINE	1
6	OLT-131	OIL LINE	1
7	OLT-132	OIL LINE	1
8	OLT-133	OIL LINE	1

REF #	PART #	DESCRIPTION	QTY.
9	OLT-134	OIL LINE	1
10	OLT-135	OIL LINE	1
11	OH-3	OIL LINE HOLDER	2
12	OH-6	OIL LINE HOLDER	1
13	OH-9	OIL LINE HOLDER	1
14	H06020-FF	3/8" X 20" HOSE	3
15	H06030-FF	3/8" X 30" HOSE	5
16	HTN0616	3/8" LOCK NUT	5