



McFARLANE
MFG. CO.
INC. Sauk City, Wisconsin

MANUFACTURERS OF QUALITY AGRICULTURAL EQUIPMENT SINCE 1936

OPERATOR'S MANUAL
AND
PARTS LISTING
FOR THE

HDL-1000 Series

1024 through 1038 Models

VERSION: 2-11
starting at serial number 14401

TO THE OWNER AND OPERATORS

Before assembling or operating this unit, READ THIS MANUAL THOROUGHLY. To obtain the best performance of the unit, familiarize yourself with each component and adjustment. Store this manual where it can be readily available for future reference. In the event that the harrow or any part of the unit should be sold, be sure that the new owner receives a copy of this manual for their reference.

1330 Dallas Street · PO Box 100 · Sauk City WI 53583
Phone (608) 643-3321 · Toll Free (800) 627-8569 · Fax (608) 643-3976
www.flexharrow.com

TABLE OF CONTENTS

INTRODUCTION	3
LIMITED WARRANTY	3
SAFETY	4
CONTACT INFORMATION.....	5
LIGHTING AND MARKING.....	6
SAFETY SIGN CARE	7
TIRE SAFETY.....	7
BEFORE OPERATION.....	7 - 8
DURING OPERATION	8 - 9
FOLLOWING OPERATION	9
HIGHWAY AND TRANSPORT OPERATIONS	9 - 10
PERFORMING MAINTENANCE	10
MAINTENANCE AND SERVICE SCHEDULE	11
OPERATING SUGGESTIONS.....	11
ASSEMBLY SUGGESTIONS.....	12
ASSEMBLY INSTRUCTIONS	13 – 27
FINAL ADJUSTMENTS	28
TROUBLESHOOTING.....	29
BOLT & TIRE SPECIFICATIONS	APPENDIX A
PARTS DIAGRAMS AND LISTS	APPENDIX B
LAYOUT DIAGRAMS.....	APPENDIX C
WARRANTY REGISTRATION FORM	LAST PAGE

INTRODUCTION

Thank you for purchasing your new McFarlane transport cart and harrow sections. We know that you will get many years of dependable service from this modernly designed unit.

You may have had a particular application in mind when you purchased this unit. There are actually many uses for the McFarlane harrow including incorporation of herbicides and pesticides, leveling and smoothing tilled soil, and covering of broadcast seeds. Contact your dealer if you would like more information or have questions concerning these or other applications.

LIMITED WARRANTY

FULL ONE - YEAR WARRANTY OF

HDL-1000-8 Series

HDL-1000-16 Series

HDL-1000-44 Series

HDL-1000-88 Series

1024 through 1038 Models

If within one year from the date of purchase, this transport cart and/or its accompanying harrow sections fail due to defect in material or workmanship, McFarlane Mfg. Co., Inc. will repair it, free of charge.

Warranty service is available by simply contacting the nearest McFarlane dealership throughout the United States or Canada.

This warranty applies only while this product is used in the United States or Canada.

This warranty gives you specific legal rights, and you may have other rights which vary from state to state.

McFarlane Mfg. Co., Inc., Sauk City, Wisconsin 53583

SAFETY

TAKE NOTE! THIS SAFETY ALERT SYMBOL FOUND THROUGHOUT THIS MANUAL IS USED TO CALL ATTENTION TO INSTRUCTIONS INVOLVING YOUR PERSONAL SAFETY AND THE SAFETY OF OTHERS. FAILURE TO FOLLOW THESE INSTRUCTIONS CAN RESULT IN INJURY OR DEATH.



THIS SYMBOL MEANS

- **ATTENTION!**
- **BECOME ALERT!**
- **YOUR SAFETY IS INVOLVED!**

SIGNAL WORDS:

Note the use of the signal words DANGER, WARNING, and CAUTION with the safety messages. The appropriate signal word for each has been selected using the following guidelines:

DANGER: Indicates an imminently hazardous situation that, if not avoided, will result in death or serious injury.

WARNING: Indicates a potentially hazardous situation that, if not avoided, could result in death or serious injury.

CAUTION: Indicates a potentially hazardous situation that, if not avoided, may result in minor or moderate injury.

CONTACT INFORMATION

If you have questions not answered in this manual, require additional copies, or the manual is damaged, please contact your local dealer or:

McFarlane Mfg. Co., Inc.
1330 Dallas Street
P.O. Box 100
Sauk City, WI 53583

PHONE: (608) 643-3321
TOLL FREE: (800) 627-8569
FAX: (608) 643-3976
INTERNET: www.flexharrow.com
EMAIL: info@flexharrow.com



SAFETY FIRST!



Equipment Safety Guidelines

Safety of the operator is one of the main concerns in designing and developing a new piece of equipment. Designers and manufacturers build in as many safety features as possible. However, every year many accidents occur which could have been avoided by a few seconds of thought and a more careful approach to handling equipment. You, the operator, can avoid many accidents by observing the following precautions. To avoid personal injury, study the following precautions and insist that those working with you, or for you, follow them.

Replace any CAUTION, WARNING, DANGER, or instruction safety decal that is not readable or missing.

Do not attempt to operate this equipment under the influence of drugs or alcohol.

Review the safety instructions with all users annually.

This equipment is dangerous to children and persons unfamiliar with its operation. The operator should be a responsible adult familiar with farm machinery and trained in this equipment's operations. **Do not allow persons to operate or assemble this unit until they have read this manual and have developed a thorough understanding of the safety precautions and of how it works.**

To prevent injury, use a tractor equipped with a Roll Over Protective System (ROPS). Do not paint over, remove, or deface any safety signs or warning decals on your equipment. Observe all safety signs and practice the instructions on them.

Never exceed the limits of the transport cart or the harrows. If their ability to do a job, or to do so safely, is in question - **DO NOT TRY IT.**



Lighting and Marking

It is the responsibility of the customer to know the lighting and marking requirements of the local highway authorities and to install and maintain the equipment to provide compliance with the regulations. Add extra lights when transporting at night or during periods of limited visibility.

Lighting kits are available from your dealer.



Safety Sign Care

- Keep safety signs clean and legible at all times.
- Replace safety signs that are missing or have become illegible.
- Replacement parts that display a safety sign should display the same sign.
- Safety signs are available from your Distributor, Dealer Parts Department, or the factory.

How to Install Safety Signs:

- Be sure that the installation area is clean and dry.
- Decide on the exact position before you remove the backing paper.



Tire Safety

- Failure to follow proper procedures when mounting a tire on a wheel or rim can produce an explosion which may result in serious injury or death.
- Do not attempt to mount tires unless you have the proper equipment and experience to do the job.
- Inflating or servicing tires can be dangerous. Whenever possible, trained personnel should be called to service and/or mount tires.
- Always order and install tires and wheels with appropriate capacity to meet or exceed the weight of the unit. Be sure to inflate tires to tire manufacturer's specifications
- Tires that are provided by the manufacturer are designed for speeds LESS THAN 20mph. Do Not exceed or tire failure will occur.



Remember:

Your best assurance against accidents is a careful and responsible operator. If there is any portion of this manual or function you do not understand, contact your local authorized dealer or the manufacturer.



Before Operation:

- Carefully study and understand this manual.
- Do not wear loose fitting clothing which may catch in moving parts.
- Always wear protective clothing and substantial shoes.
- It is recommended that suitable protective hearing and (eye protection) sight protectors be worn.
- Keep wheel lug nuts or bolts tightened.
- Assure that the tires are inflated evenly.
- Give the unit a visual inspection for any loose bolts, worn parts, or cracked welds, and make necessary repairs. Follow the maintenance safety instructions included in this manual.
- Before using the hydraulics on the cart, be sure all fittings and connections are tight.
- Be sure that there are no tools lying on the unit.
- Make sure that the area is clear of children, animals, and other obstacles before using.
- Don't hurry the learning process or take the unit for granted. Ease into it and become familiar with your new equipment. Practice operation of your new unit. Completely familiarize yourself and other operators with its operation before using.

- Securely attach to towing unit. Use a high strength, appropriately sized hitch pin with a mechanical retainer and attach safety chain.
- Do not allow anyone to stand between the tongue or hitch and the towing vehicle when backing up to the equipment.



During Operation:

- **SAFETY CHAIN** - If equipment is going to be transported on a public highway, a safety chain should be obtained and installed. Always follow state and local regulations regarding a safety chain when towing farm equipment on a public highway. Be sure to check with local law enforcement agencies for your own particular regulations. Only a safety chain (not an elastic or nylon/plastic tow strap) should be used to retain the connection between the towing and towed machines in the event of separation of the primary attaching system.
- Install the safety chain by crossing the chains under the tongue and secure to the draw bar cage or hitch or bumper frame.
- Beware of bystanders, **particularly children!** Always look around to make sure that it is safe to start the engine of the towing vehicle or move the unit. This is particularly important with higher noise levels and quiet cabs, as you may not hear people shouting.
- **NO PASSENGERS ALLOWED** - Do not carry passengers anywhere on, or in, the tractor or equipment, except as required for operation.
- Keep hands and clothing clear of moving parts.
- Do not clean, lubricate, or adjust your equipment while it is moving.
- When altering operation, even periodically, set the tractor or towing vehicle brakes, shut off the engine, and **remove the ignition key.**
- Do not operate the hydraulic cylinders without the flow restrictors installed; the free falling harrow sections may cause serious injury.
- Pick the levellest possible route when transporting across fields. Avoid the edges of ditches or gullies and steep hillsides.
- Periodically clear the equipment of brush, twigs, or other materials to prevent buildup of dry combustible materials.
- Maneuver the tractor or towing vehicle at safe speeds.
- Avoid overhead wires or other obstacles. Contact with overhead lines could cause serious injury or death.
- Allow for unit length when making turns.
- Do not walk or work under raised wings unless securely positioned in wing rests.
- Keep all bystanders, pets, and livestock clear of the work area, particularly when raising or lowering harrow sections.
- Operate the towing vehicle from the operator's seat only.
- As a precaution, always recheck the hardware on equipment periodically. Correct all problems. Follow the maintenance safety procedures.



Following Operation:

- When disconnecting, stop the tractor or towing vehicle, set the brakes, secure the wings in the wing rests, relieve hydraulic fluid pressure, shut off the engine and **remove the ignition keys**. Make sure all jack and support stands are in place before removing hitch pins.
- Store the unit in an area away from human activity on a hard level surface.
- Do not park equipment where it will be exposed to livestock for long periods of time. Damage and livestock injury could result.
- Do not permit children to play on or around the stored unit.



Highway and Transport Operations:

- Make sure all transport lock provisions are in place and jack/parking stands are in their storage position before transporting the unit.
- Adopt safe driving practices:
 - Keep the brake pedals latched together at all times. **NEVER USE INDEPENDENT BRAKING WITH MACHINE IN TOW AS LOSS OF CONTROL AND/OR UPSET OF UNIT MAY RESULT.**
 - Always drive at a safe speed relative to local conditions and ensure that your speed is low enough for an emergency stop to be safe and secure. Keep speed to a minimum.
 - Reduce speed prior to turns to avoid the risk of overturning.
 - Avoid sudden uphill turns on steep slopes.
 - Always keep the tractor or towing vehicle in gear to provide engine braking when going downhill. Do not coast.
 - Do not drink and drive!
- Comply with state and local laws governing highway safety and movement of farm machinery on public roads.
- Use approved accessory lighting flags and necessary warning devices to protect operators of other vehicles on the highway during daylight and nighttime transport. Various safety lights and devices are available from your dealer.
- The use of flashing amber lights is acceptable in most localities. However, some localities prohibit their use. Local laws should be checked for all highway lighting and marking requirements.
- When driving the tractor and equipment on the road or highway under 20 mph at night or driving during the day, use flashing amber warning lights and a slow moving vehicle (SMV) identification emblem.
- Remember, tires supplied by the manufacturer are designed to operate LESS THAN 20mph. Do Not exceed or tire failure will occur.
- Be a safe and courteous driver. Always yield to oncoming traffic in all situations, including narrow bridges, intersections, etc. Plan your route to avoid heavy traffic.

- Be observant of bridge loading ratings. Do not cross bridges rated lower than the gross weight at which you are operating.
- Watch for obstructions overhead and to the side while transporting.
- Always operate equipment in a position to provide maximum visibility at all times. Make allowances for increased length and weight of the equipment when making turns, stopping, etc.



Performing Maintenance:

- Good maintenance is your responsibility. Poor maintenance is an invitation to trouble.
- Before working on this machine, stop the tractor or towing vehicle, set the brakes, lower into field position, relieve the hydraulic fluid pressure, shut off the engine and **remove the ignition keys**.
- **Always** use safety support and block the wheels. When performing maintenance, never use a jack to support the machine. Assist the jack with blocks or other adequate support.
- Use extreme caution when making adjustments.
- When disconnecting hydraulic lines, shut off hydraulic supply and relieve all pressure.
- Never use hands to locate a hydraulic leak on attachments. Use a piece of cardboard or wood. Hydraulic fluid escaping under pressure can penetrate the skin.
- Openings in the skin and minor cuts are susceptible to infection from hydraulic fluid. **If injured by escaping hydraulic fluid, see a doctor at once. Gangrene can result. Without immediate medical treatment, serious infection and reactions can occur.**
- When installing, replacing, or repairing hydraulic system cylinders or parts, make sure that the entire system is charged and free of air before resuming operations. Failure to bleed the system of all air can result in improper machine operation, causing severe injury.
- After servicing, be sure all tools, parts, and service equipment are removed.
- Never replace hex bolts with less than grade five bolts unless otherwise specified.
- Where replacement parts are necessary for periodic maintenance and servicing, genuine factory replacement parts must be used to restore your equipment to original specifications. The manufacturer will not claim responsibility for damages as a result of the use of unapproved parts and/or accessories.
- If equipment has been altered in any way from original design, the manufacturer does not accept any liability for injury or warranty.

MAINTENANCE AND SERVICE SCHEDULE

- Prior to each use, check for loose bolts and replace lost or worn parts.
- Grease hinge pins before each use when necessary.
Note: Clean grease fittings and replace those that are broken or missing.
- Inspect and repack wheel bearings at the beginning of each year.
- Remove dirt and debris from the harrow sections before storage.
- Parts diagrams and listings for service and repair references may be found in appendix B.

OPERATING SUGGESTIONS

There are some important points to remember in order to obtain the best possible results from your McFarlane harrow.

- To maximize the harrow's performance, it should be towed at speeds ranging from six to nine (6 - 9) mph. This keeps the field debris moving through the harrow sections and avoids clogging. The best results will be obtained after the paint has been scoured from the teeth.
- Choose the angle of attack of the harrow teeth based on field conditions. For more information see the section titled Angle of Attack.
- Getting the unit ready for transport includes the following steps:
 1. Rotate the harrow sections up.
 2. Swing the wings forward and lock them into the wing rests.
- Getting the unit ready for field use includes the following steps:
 1. Unlock the wings from the wing rests and swing the wings out.
 2. Rotate the harrow sections down.
- If the wing cables are not tight, adjust the bracket on the wing outward to tighten them. Follow the instructions in the section titled Attach the Wing Cables.

ASSEMBLY SUGGESTIONS

- You will find the machine is easier to assemble if the set-up instructions are followed in the order given in the manual.
- Before beginning, sort the various bolt bags, hardware bags and hydraulic bags according to what part of the unit that is being setup. Refer to the end of the parts listing in appendix B. Only open the bag or bags that are required as the setup instructions are followed.
- Whenever the terms “left” and “right” are used, it should be understood to mean when standing behind and facing the unit. This is also known as the “driver’s left” and the “driver’s right.”
- The term “field position” refers to the position the harrows are in when the unit is being used in the field - that is, with the wings out and the harrow sections down.
- The term “transport position” refers to the position the harrows would be in when the unit is being transported from place to place - that is, with the harrows up and the wings folded and secured in the wing rests.
- When assembling this unit, make sure that the parts are securely held before proceeding to the next step.
- Bolt torque specifications are given in appendix A.
- The hydraulic cylinder and hose requirements are listed in the parts listing in appendix B. It is not recommended that other size cylinders or hoses be substituted. Hoses are marked with the part number near the ends. The last three digits indicate the hose length in inches. Fittings with a restrictor are marked with an ‘R’.
- A dual acting hydraulics supply is required. The unit is designed for the standard ASAE pressure of 1500 psi.
- Tire requirements are also listed in the parts listing in appendix B.
- Layout diagrams for each unit may be found in appendix C. Mark the page with the diagram that refers to your unit, it will be referred to periodically throughout the manual.

STEP - BY - STEP ASSEMBLY INSTRUCTIONS

Main Frame Assembly

1. Bolt the Square Frame to the A-frame. Use 5/8" x 2" bolts, lock washers, and hex nuts.
2. Bolt the Axle Brackets to the main frame. Use 5/8" x 2" bolts, lock washers, and hex nuts.
3. Attach the hub with spindle to the Axle Bracket using 1/2" x 3 1/2" grade 8 bolts and lock nuts.
4. Mount the wheels to the main frame Axle Brackets. Be sure the valve stem is pointing away from the Axle Bracket.
5. Attach the jack to the A-frame.

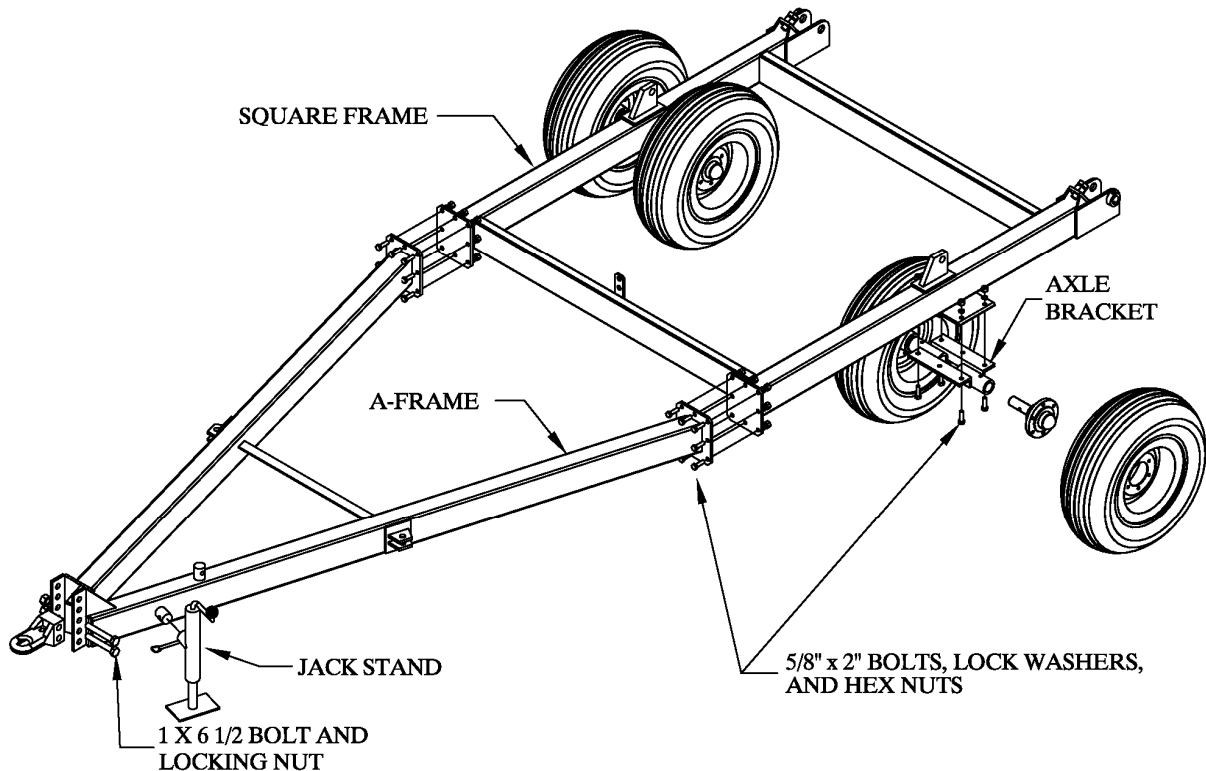

Figure 1

6. Assemble either a clevis hitch (Figure 2) or a pintle hitch (Figure 3) as required by the tractor or towing vehicle. Note the opposite orientation of the base hitch for each hitch type. Attach the hitch assembly to the A-frame with two 1" x 6 1/2" bolts and locking nuts.

Note: Parts have been provided to assemble a clevis hitch or a pintle hitch. Not all the included parts will be needed to assemble either type of hitch. Be sure to store the extra parts in a safe place; they will be needed if one requires the use of the other hitch type.

Note: For clarity purposes, the rest of the diagrams will be shown with out the main axles and rims.

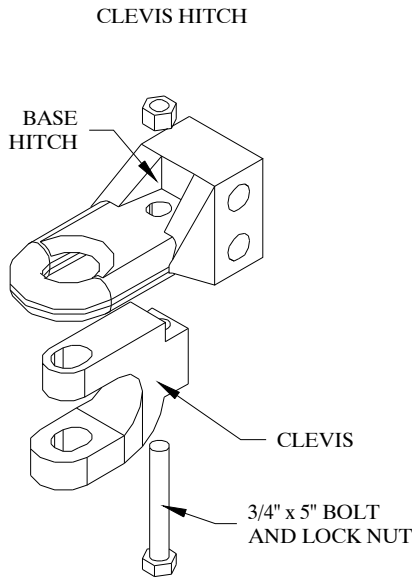

Figure 2

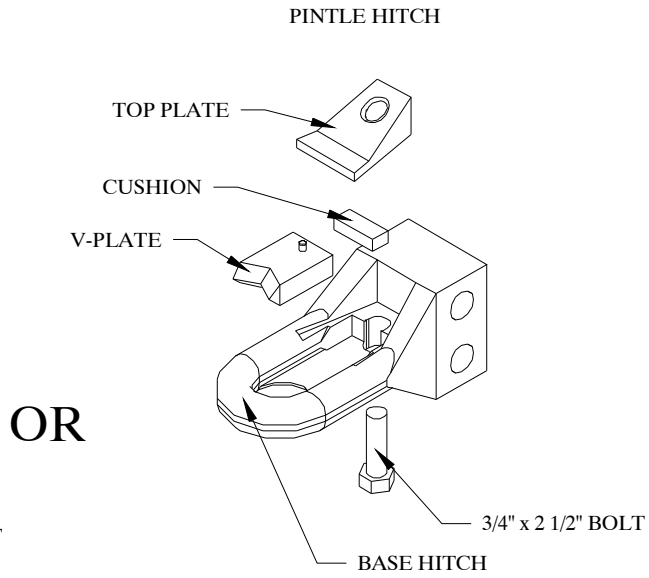

Figure 3

7. Attach the wing rests to the square frame. Refer to Figure 4. Use four 5/8" x 6" x 5 1/2" U-bolts, lock washers, and hex nuts. Do *not* tighten yet. The distance ("D" in Figure 4.) from square frame splice plate to the wing rest mounting plate varies with the model:

HDL-1024	HDL-1026	HDL-1028	HDL-1030	HDL-1032	HDL-1034	HDL-1036	HDL-1038
21"	30"	30"	30"	8"	12"	12"	8"

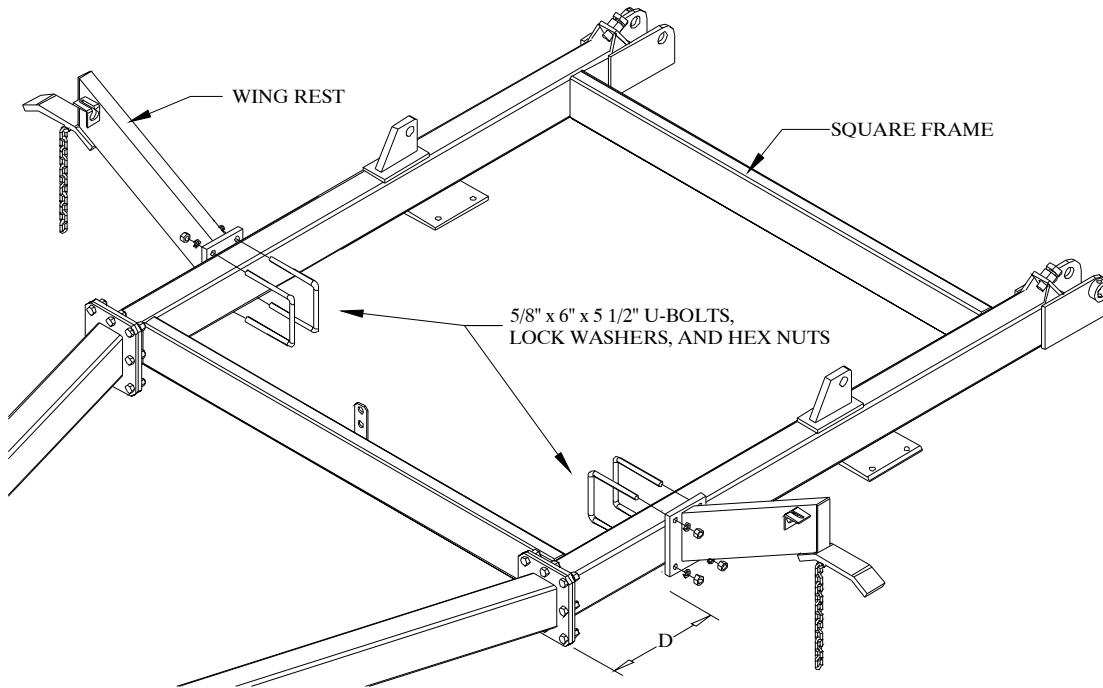

Figure 4

Attach the Center Bar to the Square Frame

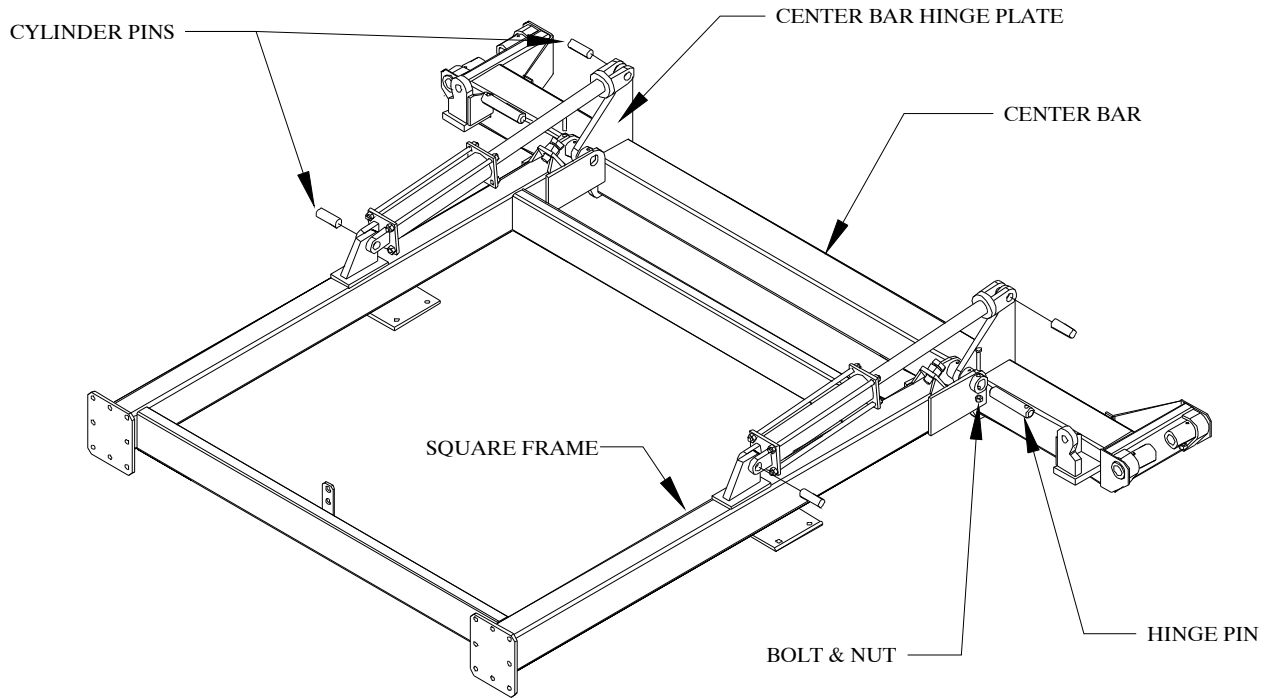

Figure 5

1. Attach the center bar to the square frame. Refer to Figure 5. Use the 1 ½" x 7 1/16" hinge pins, ½" x 3" grade 8 bolts, and locking hex nuts.
2. Attach the ASAE 3 1/2" x 16" cylinders to the cylinder posts on the square frame. Note the locations of the ports and the direction of travel.

Attach the Wings to the Center Bar

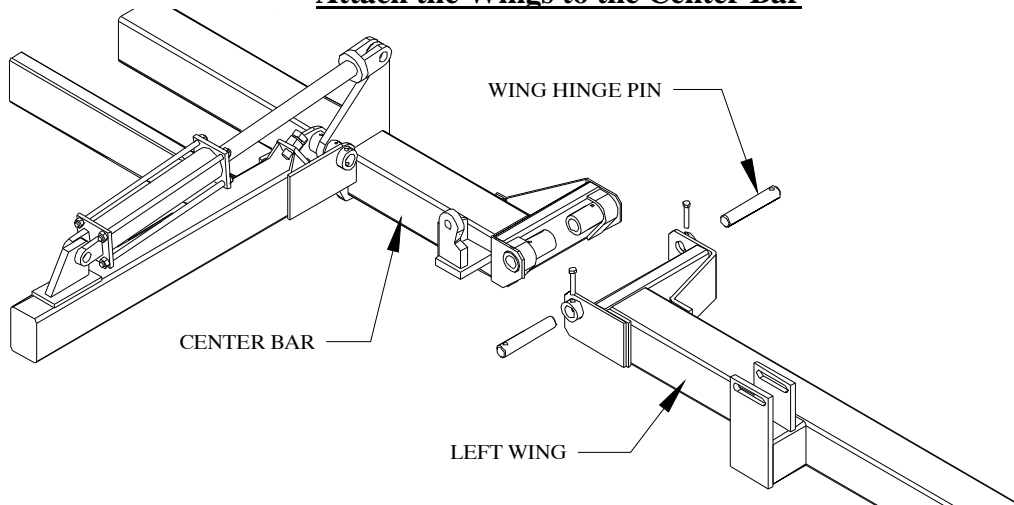

Figure 6

Attach the wings to the center bar using two 1 ½" x 8 5/16" hinge pins and the ½" x 3" grade 8 bolts and locking hex nuts. Note the location of the wing cylinder posts (figure 6) and the orientation of the wing axle mount plate (figure7).

Attach the Wing Wheels

(Refer to Figure 7)

1. Attach the hub with spindle to the Axle Bracket using ½" x 3 1/2" grade 8 bolts and lock nuts.
2. Mount the wheels to the wing frames. Be sure the valve stem is pointing towards the outside.

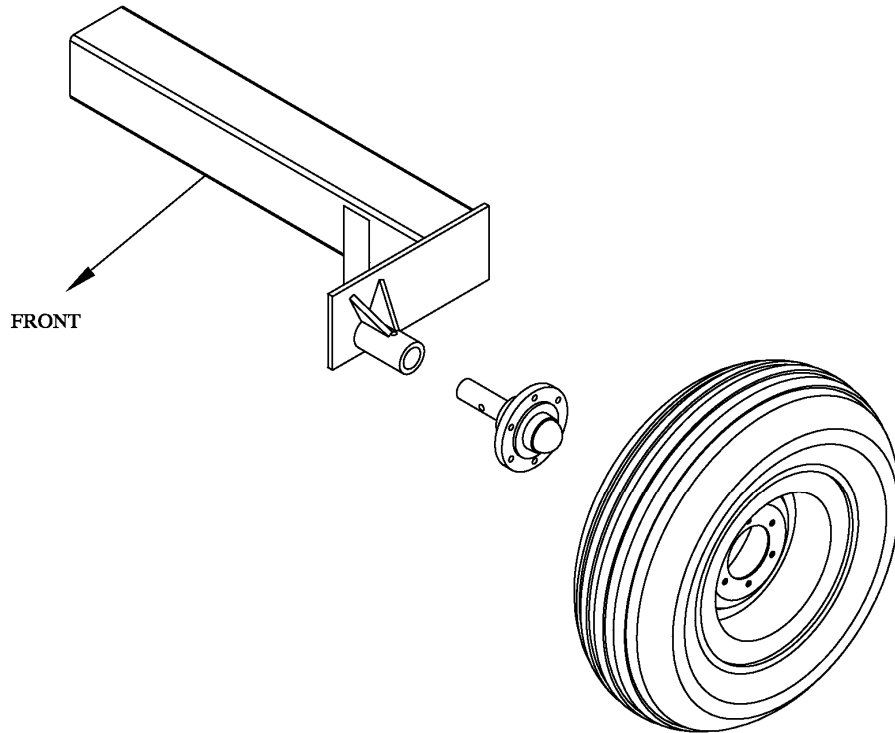

Figure 7

The remainder of the assembly steps (except for the wing cable attachment and the cable lift attachment) can be done in either the transport or field position. Because most people will assemble the unit in the field position (and it is recommended that you do), for clarity, the following diagrams show the unit in the field position.

Install the Main Frame Hydraulics

Refer to Figure 8 and the hydraulic system diagram in appendix B for more details.

1. Place a 3/8" to 1/2" o-ring adapter on each of the male tees (with one o-ring fitting) and insert the pair into the ports on the main frame cylinders. Do *not* over tighten.
2. Attach the two similar male tees (the ones without an o-ring fitting) to the hydraulic tee bracket in the middle of the square frame using the tee nuts.
3. Attach the two 84" hoses from the front tee to the front tee of the main lift cylinders. Be sure to run the hoses through the loops welded to the frame.
4. Attach the two 108" hoses from the front tee to the rear tee of the main lift cylinders. Be sure to run the hoses through the loops welded to the frame.
5. Attach the two longest hoses from the front tee to the hitch. Be sure to connect the correct hose (one of the hoses has a restrictor in the end fitting) to each of the tees. Refer to the parts diagram in appendix B for details. Be sure to run the hoses through the loops welded to the frame.

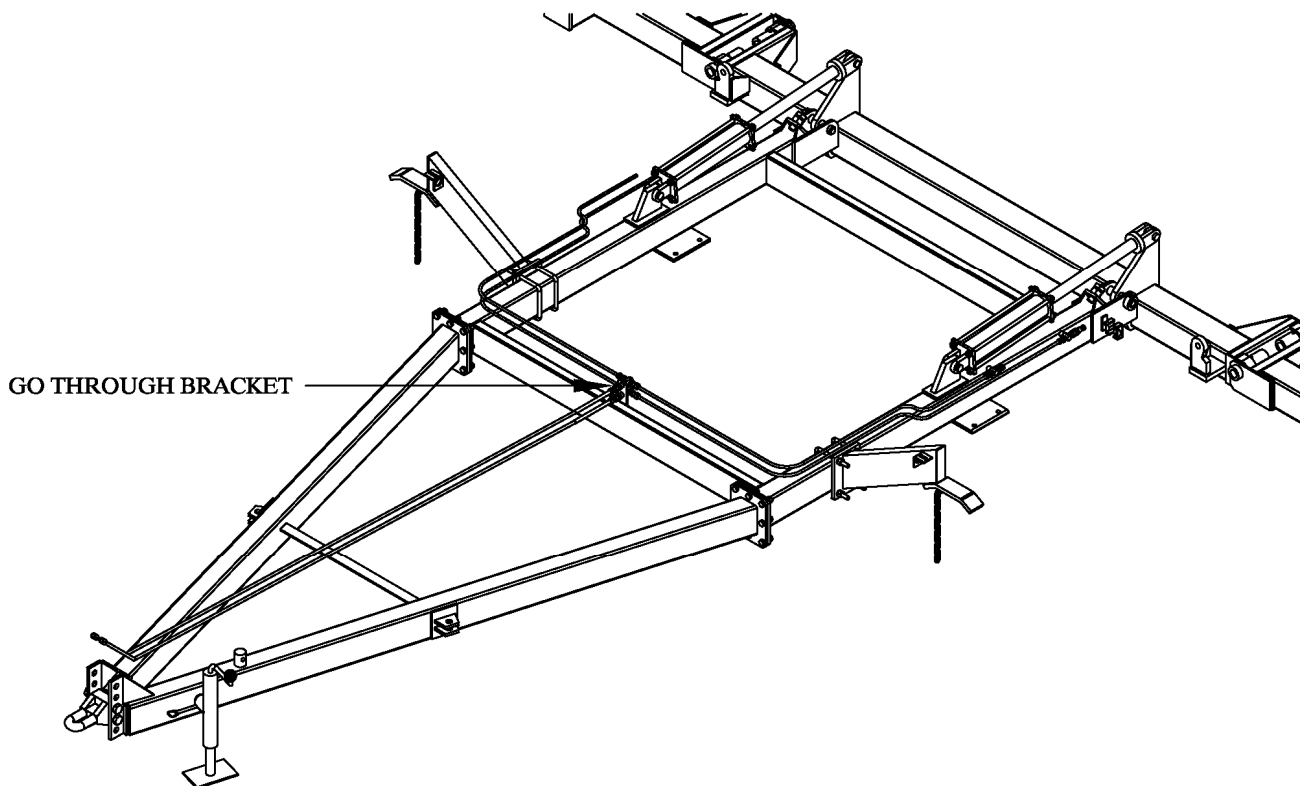

Figure 8

Install the Wing Hydraulics

Refer to Figure 9 and the hydraulic system schematic in appendix B for more details.

1. Insert a 3/8"m – 1/2o-ring elbow into each of the base end ports on the 3" x 14" cylinders. Note the locations of the ports on the cylinders - ports face forward. Refer to the parts diagram on page 36 for details. Do *not* over tighten.
2. Insert a 3/8" – 3/8o-ring elbow with restrictor in each of the rod end ports of the 3" x 14" cylinders. Refer to the parts diagram on page 36 for details. Do *not* over tighten.
3. Attach the cylinders to the cylinder posts on the center bar and wings.
4. Attach a 3/8" x 54" hydraulic hose to each of the 3/8" elbows in the wing cylinders.
5. Attach the hoses in the outer ports on the wing cylinders to the tee in the rear ports of the main frame cylinders. Attach the remaining hoses between the inner elbows on the wing cylinders and the front tee of the main frame cylinders.

Before further assembly, the hydraulic system must be filled with oil. Attach the unit to a tractor and connect the hydraulic lines. Using hydraulic controls, rotate the center bar and wings several times to fill the cylinders and hoses with oil.

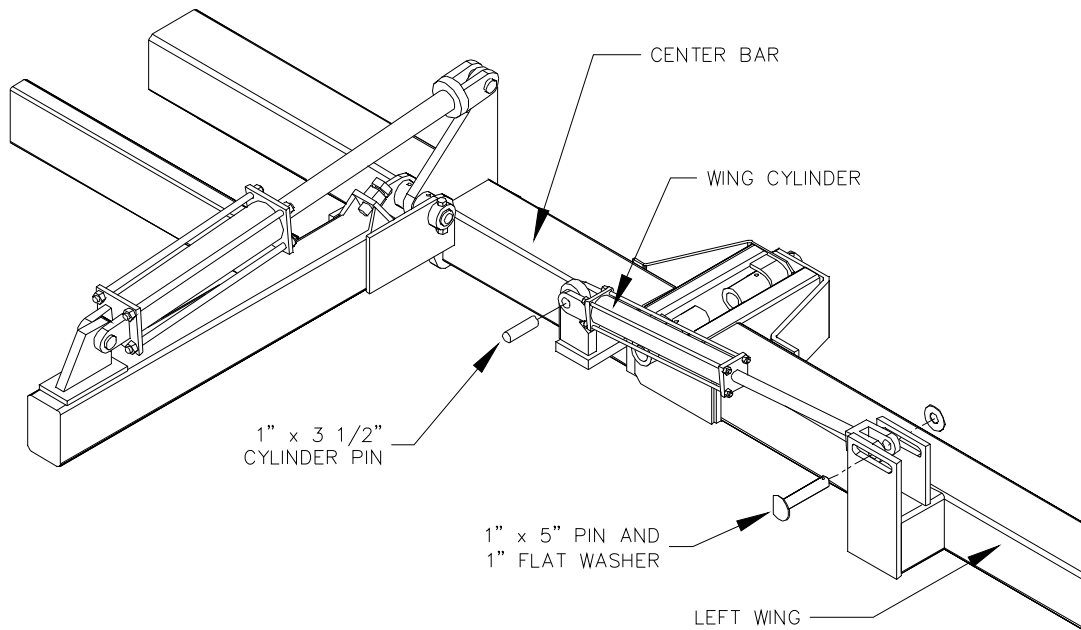

Figure 9

Harrow Configurations

McFarlane harrow sections may be attached in any one of several distinct configurations: 8-bar, 4+4-bar, 12-bar, 8+4-bar, 16-bar, and 8+8-bar. The 8, 12, and 16-bar harrow configurations utilize a single set of pull points located adjacent to the center bar and wings. The 4+4, 8+4, and 8+8-bar harrow configurations (also known as dual sections) also utilize a second set of pull points located at the rear end of the lift arms. Persons assembling an 8, 12, or 16-bar harrow should **ignore** the instructions in *italics* describing the attachment of the rear pull points. Those assembling a dual section harrow should be sure to **follow** the instructions for attaching the rear pull points in *italics*.

Mount the Lift Arms

1. Refer to the appropriate layout diagram in appendix C. Note the dimensions for the lift arm locations. Place a mark on the center bar and wings at the locations for each of the lift arms. Be sure the dimensions are for your unit.
2. Center a lift arm on each of these marks and secure using two $\frac{1}{2}$ " x $9\frac{1}{2}$ " bolts, lock washers, and hex nuts for each lift arm. Refer to Figure 10.

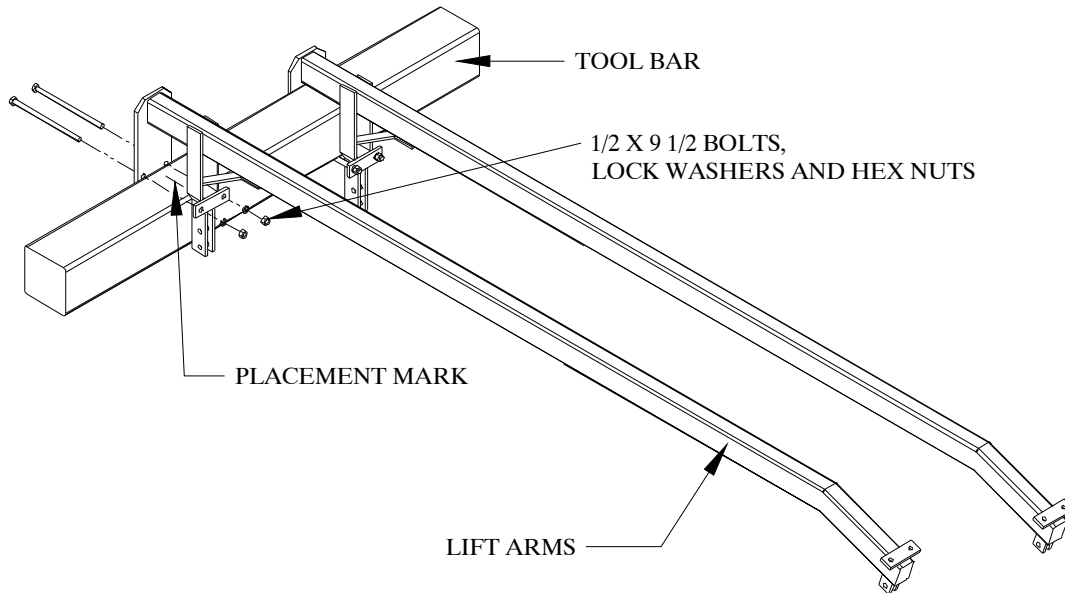

Figure 10

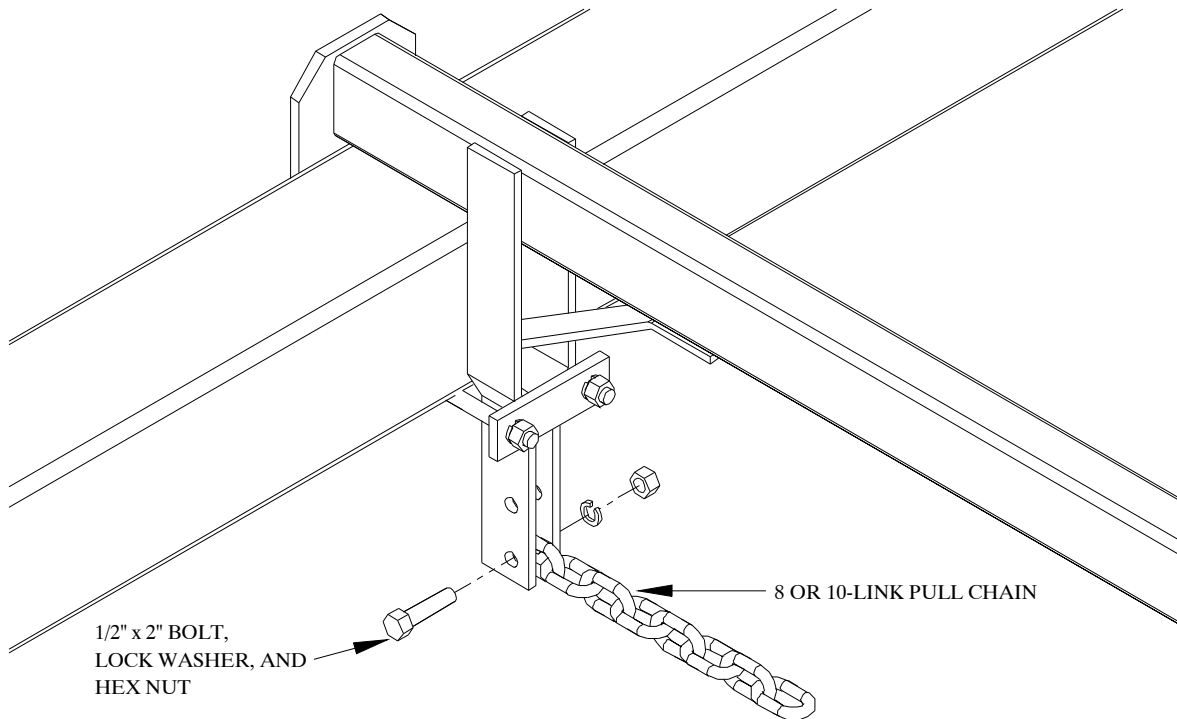

Figure 11

3. Bolt an 8 or 10-link pull chain in between each of the lift arm pull points. (10-link for 8-bar harrow sections; 8-link for all other configurations.) Use $\frac{1}{2}$ " x 2" bolts, lock washers, and hex nuts. Refer to Figure 11.
4. Bolt an 8-link lift chain between the chain tabs at the rear end of each lift arm. Refer to Figure 12. This chain will go down and connect to the last bar of a 4 or 8-bar harrow section or to the connector link for 16-bar sections.

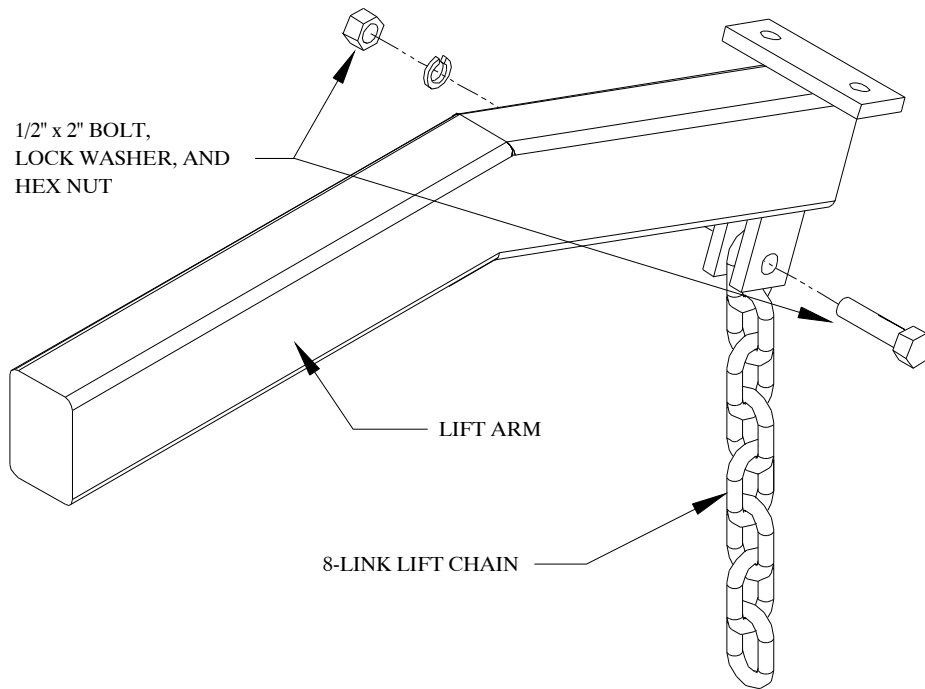

Figure 12

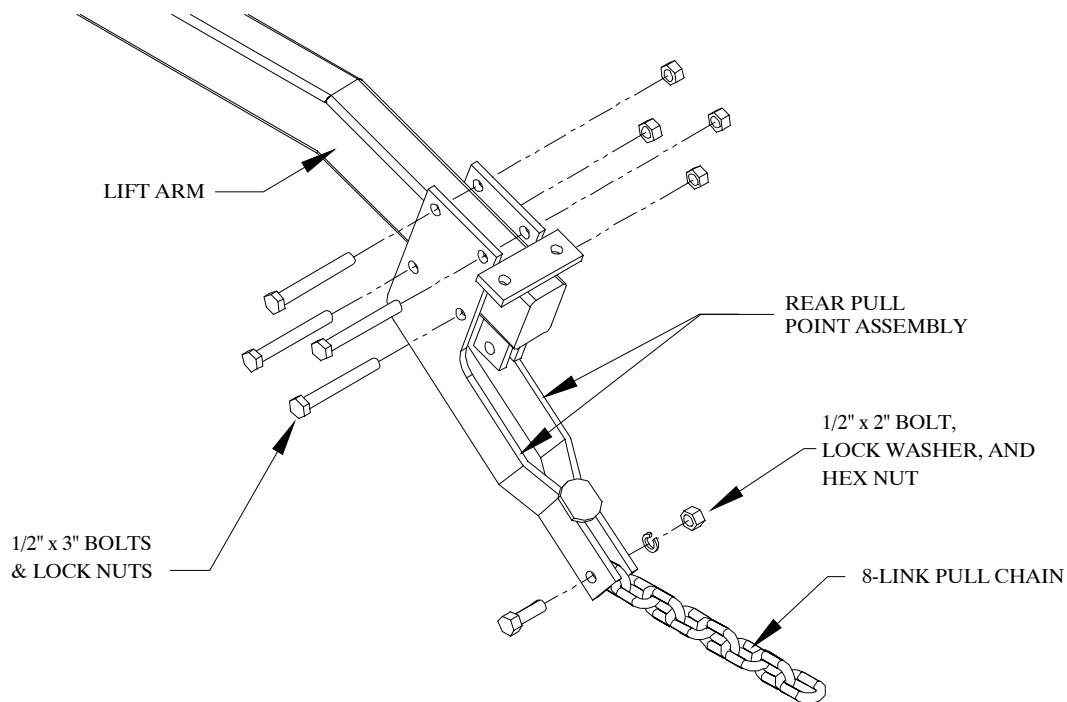

Figure 13

5. *Attach a rear pull point assembly to the rear end of each lift arm. Use four 1/2" x 3" bolt and lock nuts. Refer to Figure 13.*
6. *Bolt an 8-link pull chain to the end of the rear pull point assembly with a 1/2" x 2" bolt, lock washer, and hex nut. Refer to Figure 13. This chain will connect to the first bar of the second set of harrow sections.*
7. Refer to the layout diagrams in appendix C for the locations of the different lengths of stabilizer angles. Bolt the stabilizer angles to the bolt plates near the rear end of the lift arms. Refer to Figure 14. Use 7/16" x 1 1/4" bolts, lock washers, and hex nuts.

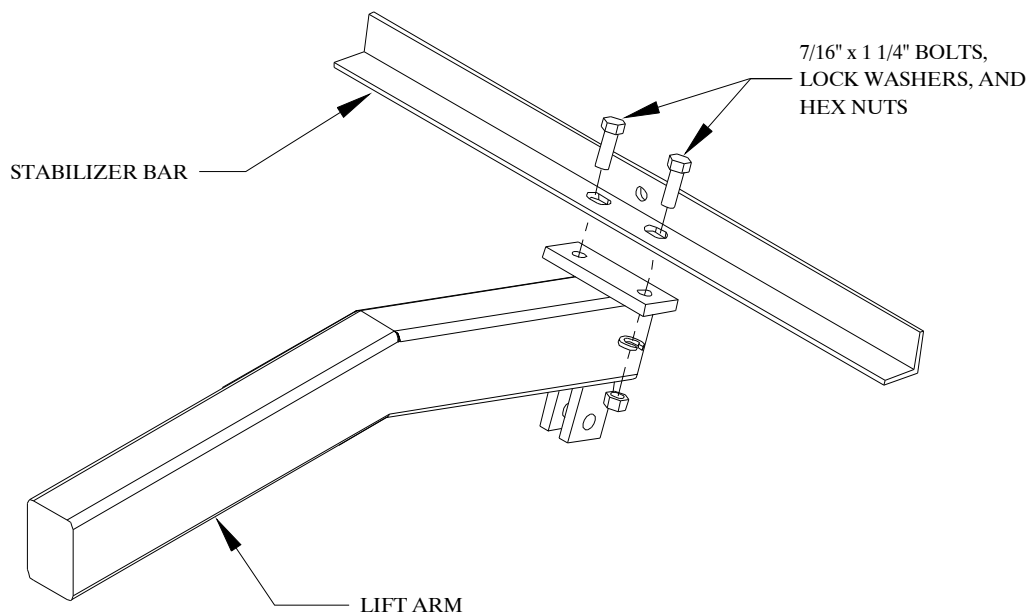

Figure 14

Angle of Attack

Before actually placing the harrows, you may want to determine the ‘angle of attack’ desired for your particular application. Refer to Figure 15 to help clarify what is meant by ‘angle of attack.’ McFarlane flexible harrow sections have a built-in system which allows the harrow owner a choice between a steep or shallow angle of attack. To change the angle of attack, simply reverse the harrow section and pull it from the other end.

Each angle has its advantages and disadvantages. The steeper the angle of attack, the more aggressive the harrowing action. However, the steeper the angle, the greater the tendency there is for the sections to clog with field debris.

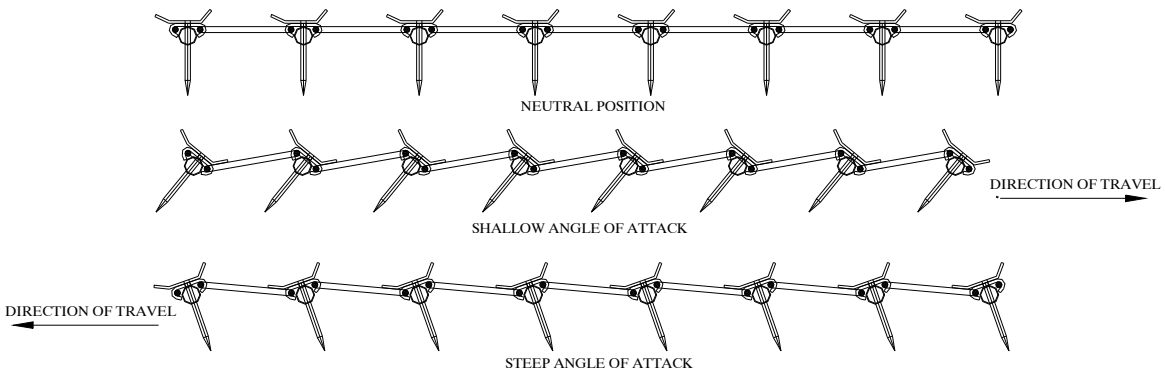

Figure 15

Harrow Identification

The number of teeth on a bar is the same as the first digit of the harrow identification number. The last number is the number of bars per section. An FH-600-8 would have six teeth per bar and 8 bars; an FH-800-8 would have eight teeth per bar and 8 bars.

Attach the Harrow Sections

Now that you have determined the desired angle of attack and identified the harrow sections, position the harrow sections on the ground under each pair of lift arms. Refer to the layout diagrams in appendix C to determine the placement of the harrow sections.

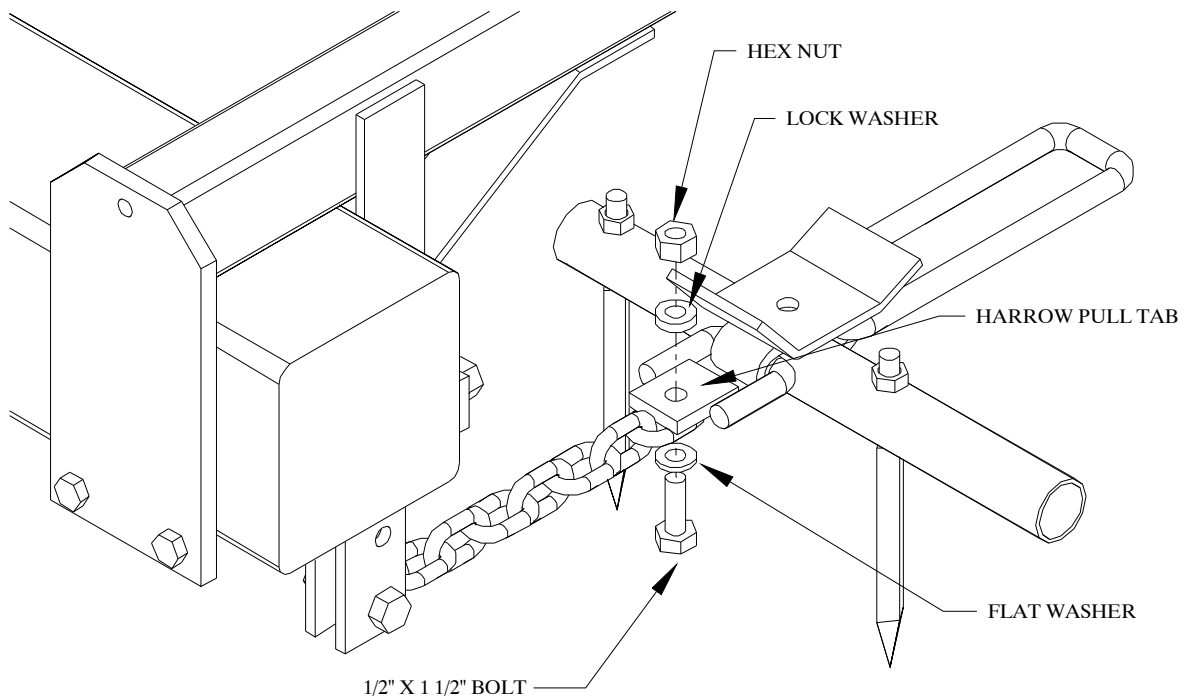

Figure 16

Instructions follow for attaching the harrow sections. Be sure to follow the instructions corresponding to your configuration.

Connect an 8-Bar Section

1. Bolt the pull chains to the front tabs on the harrow sections. Refer to Figure 16. Use $\frac{1}{2}$ " x $1\frac{1}{2}$ " bolts, flat washers, lock washers, and hex nuts. The chains should be bolted to the bottom of the pull tabs. Make sure that the chains are not twisted.
2. Bolt the lift chains to the bottom of the rear lift tabs of the harrow sections. Refer to Figure 17. Use $\frac{1}{2}$ " x $1\frac{1}{2}$ " bolts, flat washers, lock washers, and hex nuts. Make sure the chains are not twisted.

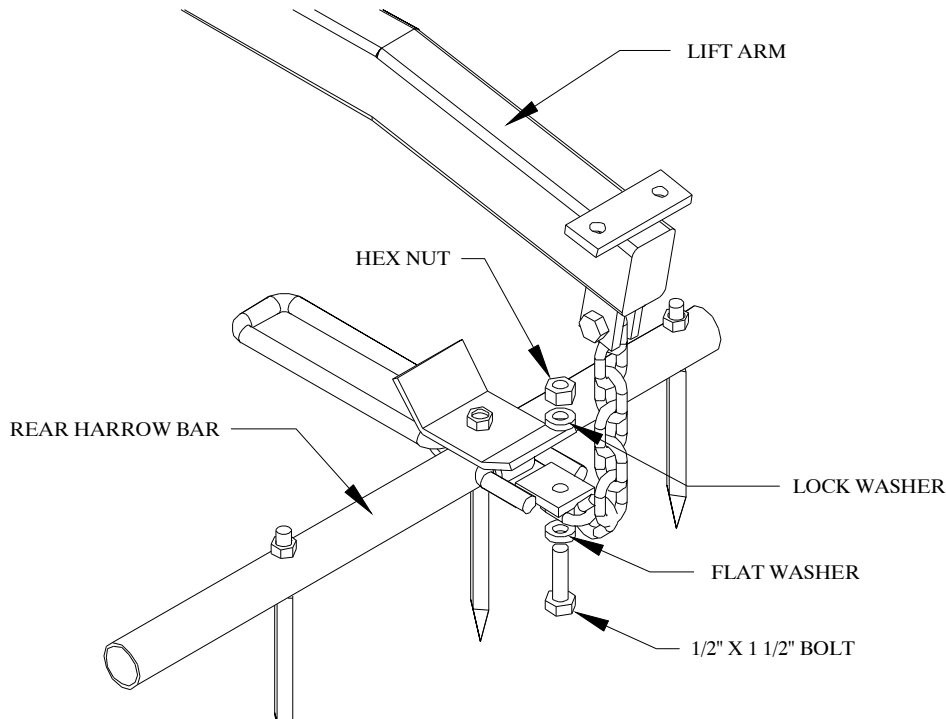

Figure 17

Connect a 12 or 16-Bar Section

1. Bolt the pull chains to the front tabs on the front harrow sections. Refer to Figure 16. Use $\frac{1}{2}$ " x $1\frac{1}{2}$ " bolts, flat washers, lock washers, and hex nuts. The chains should be bolted to the bottom of the pull tabs.
2. Bolt the front and rear harrow sections together using two $\frac{5}{16}$ " x $1\frac{1}{2}$ " x 6" dual section connector links at each pull tab. Refer to Figure 18. Use two $\frac{1}{2}$ " x 2" bolts, lock washers, and hex nuts. Do *not* tighten yet.
3. Bolt the lift chains to the dual section connector links. Use one $\frac{7}{16}$ " V-bolt and two lock nuts on each link. Tighten all dual section connector link bolts.
4. Make sure that the harrow sections match each other, the angle of attack is correct, and the chains are not twisted.

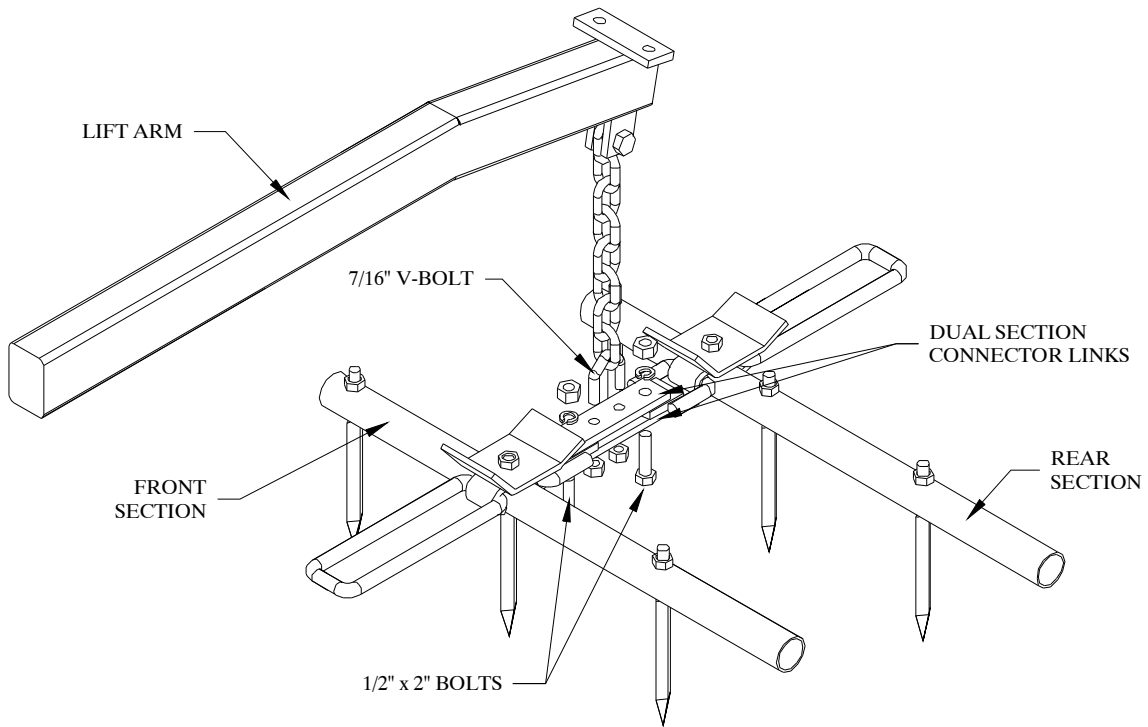

Figure 18

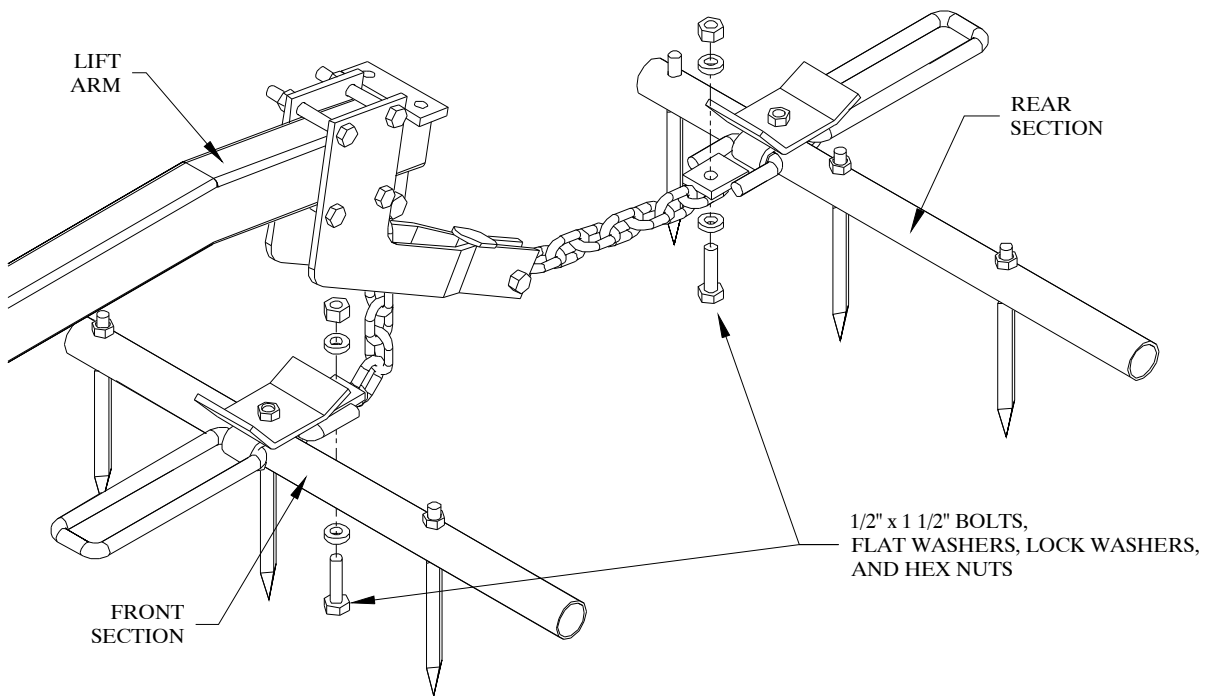

Figure 19

Connect Dual Sections

1. Bolt the pull chains to the front tabs on the harrow sections. Refer to Figures 16 and 19. Use 1/2" x 1 1/2" bolts, flat washers, lock washers, and hex nuts. The chains should be bolted to the bottom of the pull tabs.

2. Bolt the lift chains to the bottom of the rear lift tabs of the front harrow sections. Refer to Figure 19. Use $\frac{1}{2}$ " x $1\frac{1}{2}$ " bolts, flat washers, lock washers, and hex nuts.
3. Make sure that the harrow sections match each other, the angle of attack is correct, and the chains are not twisted.

For the next two steps you will need enough room to lower both wings completely. **Be sure the unit is attached to a tractor of adequate size before actuating the hydraulics!**

Attach the Wing Cables

1. Open both wings so that they are straight out and in line with the center bar. Rotate the harrow sections down into the field position.
2. Pin one end of a wing cable to the tab on the side of the A-Frame as shown in Figure 20. Use one 1 " x $2\frac{1}{2}$ " clevis pin and $\frac{3}{16}$ " x 2 " cotter pin.

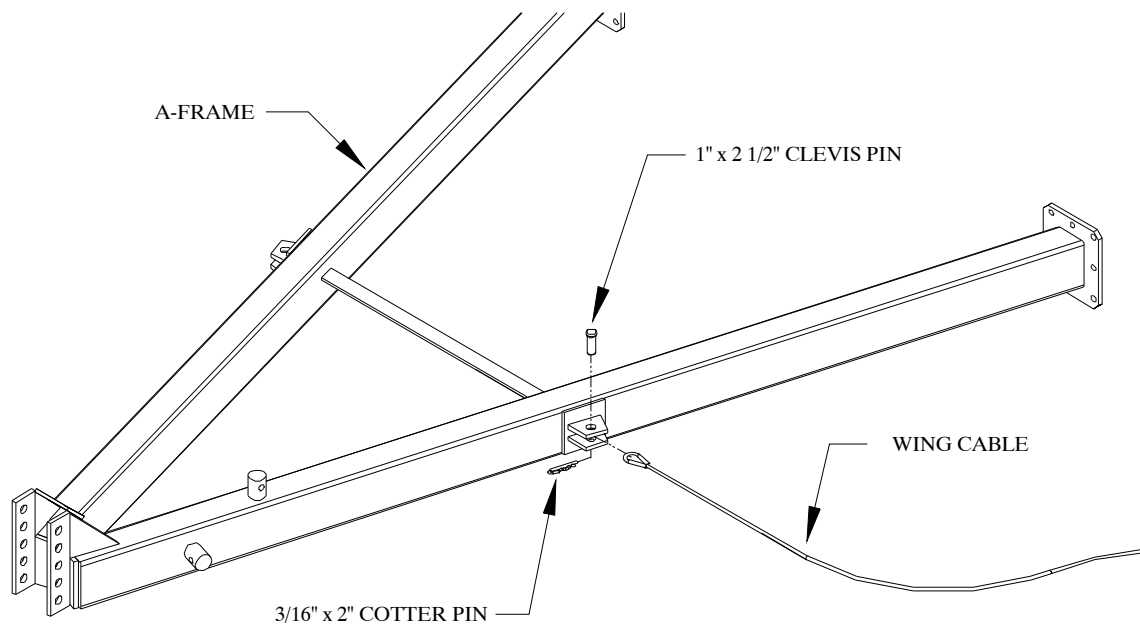

Figure 20

3. Pin the wing cable bracket to the free end of the wing cable using a 1 " x $2\frac{1}{2}$ " clevis pin and $\frac{3}{16}$ " x 2 " cotter pin. Refer to Figure 21.
4. Stretch the wing cable out so that it is tight and bolt the bracket and clamp plate to the wing. Use four $\frac{5}{8}$ " x $2\frac{1}{2}$ " bolts, lock washers, and hex nuts. Pull the cable tight by sliding the bracket outward on the wing until it is aligned with the center bar and the cable is pulled tight. Tighten the bracket.
5. Repeat on the other wing.

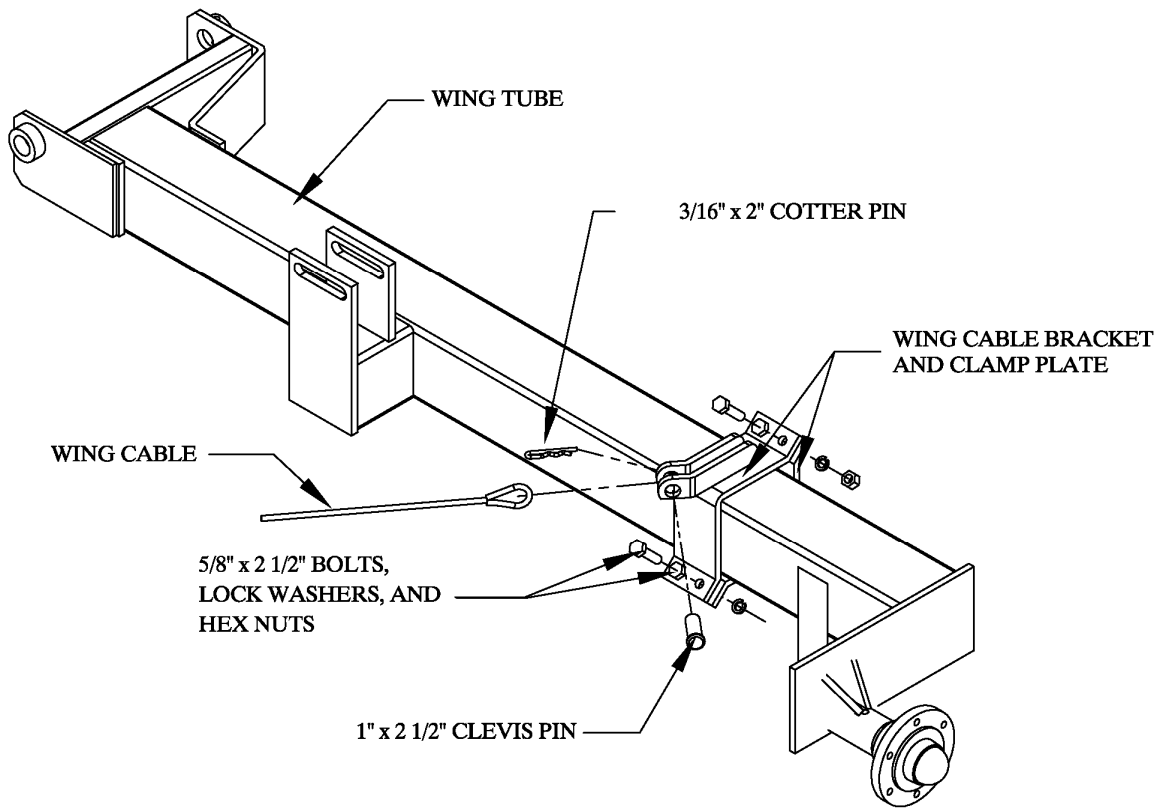

Figure 21

Attach the Wing Cable Lift Assembly

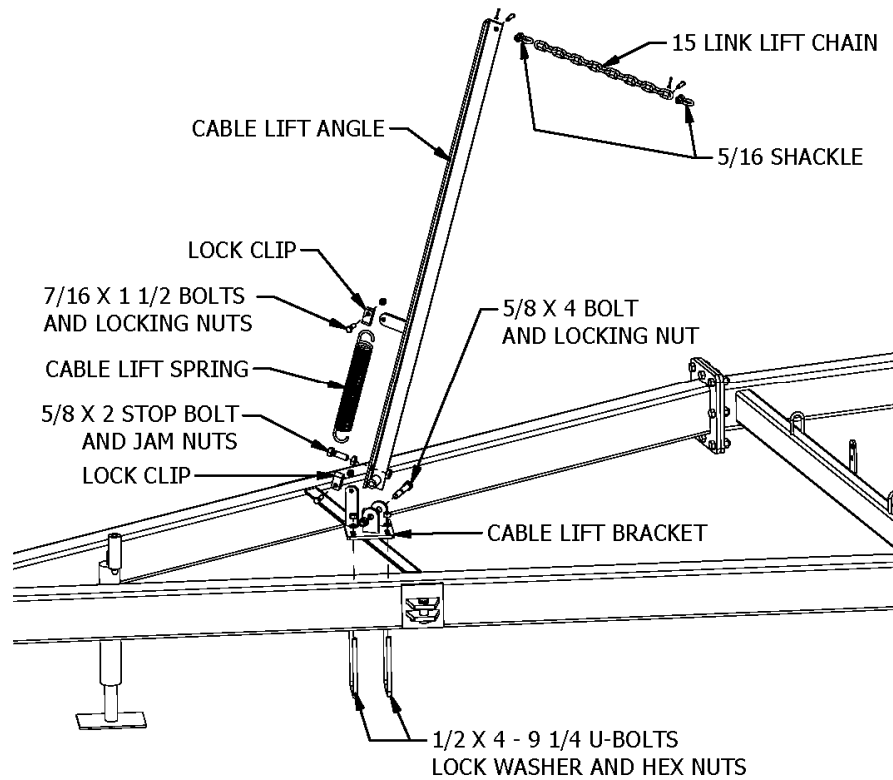

Figure 22

1. Bolt the cable lift bracket to the A-Frame just ahead of the wing cable bracket located on the side of the A-Frame. Refer to Figure 22. Use two $1\frac{1}{2}$ x 4" x $7\frac{1}{4}$ " U-bolts, lock washers, and hex nuts. Do *not* tighten yet. Note: There is a left hand and right hand assembly.
2. Bolt the cable lift angle to the cable lift bracket. Use the $\frac{5}{8}$ " x 4" bolt and lock nut.
3. Attach the cable lift spring to the tabs on the cable lift bracket and the cable lift angle. Use the lock clips and $\frac{7}{16}$ " x 1- $\frac{1}{2}$ " bolts with lock nuts.
4. Attach the $\frac{1}{4}$ " x 15-link lift chain to the cable lift angle with a $\frac{5}{16}$ shackle, shackle pin and cotter pin.
5. Adjust the assembly so that the chain on the cable lift tube hangs directly above the cable when the cart is in the field position and the cable is pulled tight.
6. Using the shackle on the free end of the cable lift angle chain, attach the wing cable lift chain.
7. Rotate the wings into the transport position. If the cables are touching the ground, the cable lift bracket assembly needs to be moved forward towards the hitch until the cable is clear of the ground. When properly adjusted, tighten all bolts.

Adjust the Wing Rests

Adjust the position of the wing rests so that they provide support to the wings while in the transport position. Refer to Figure 23. Move them either backward or forward on the square frame until the wings rest solidly on the wing rest plate. If necessary, adjust the clevis on the main frame cylinder in/out to move the wings up/down. Adjust the stop bolt tight against main hinge plate when the unit is in the transport position and secure with the jam nut. Main hinge plate stop bolt **MUST** be adjusted **AFTER** cylinder has been adjusted. When adjusted properly, tighten all bolts. Be sure to wrap the chains around the wing tubes for security during transport.

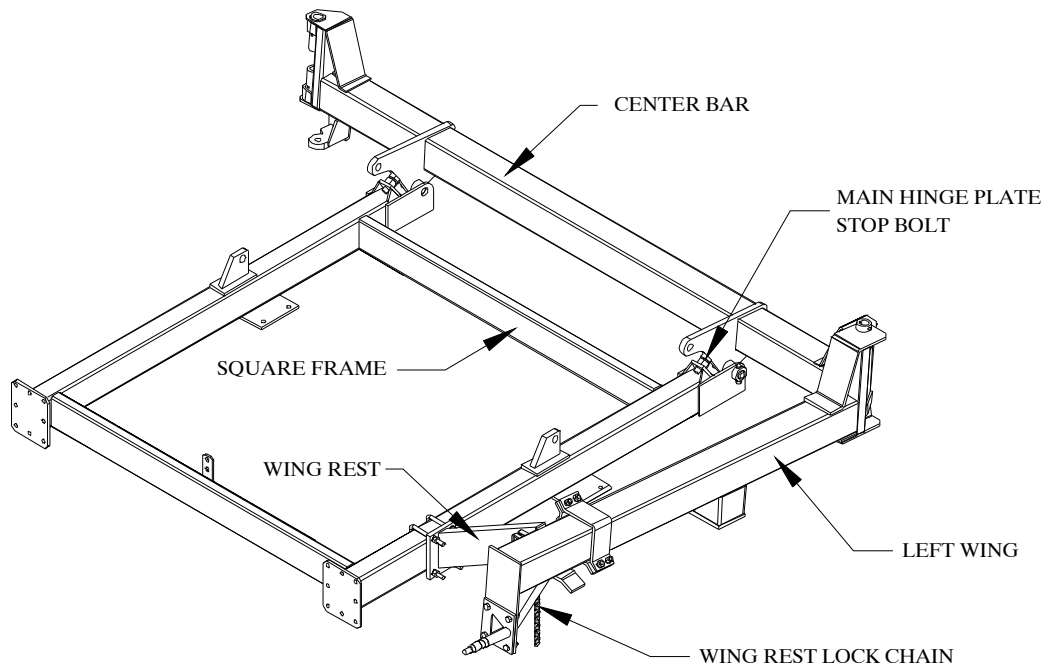

Figure 23

Final Adjustments

1. Unfold the unit into the field position.
2. Pull the completed unit ahead a few feet to check that everything is properly assembled and that nothing is binding or misaligned.
3. Check to make sure that all bolts and fasteners are tight.
4. With the unit in the transport position, attach the red and amber reflectors at the widest visible points. The red reflectors should be visible from the rear of the unit, and the amber reflectors should be visible from the front of the unit.
5. Do not detach the unit from the tractor unless the jack stand is down and the wings are secured in the wing rests.
6. After the first few hours of operation, check all fasteners and tighten if necessary. Include wheel lugs.

This completes the assembly of your harrow and transport cart. Before using the unit, double check that all components have been assembled properly. If there are any questions regarding any of the assembly steps, contact your local dealer for an explanation. Do not operate this or any equipment unless you are sure that all components operate as they were designed to operate.

TROUBLESHOOTING

PROBLEM	POSSIBLE CAUSE	SOLUTION
Hydraulics actuate too rapidly	Hydraulic restrictors not installed	Install hydraulic restrictors
Wings will not slide into wing rests	Wing rests improperly positioned	Reposition wing rests
	Main hinge plate stop bolt maladjusted	Readjust hinge plate stop bolt
Excessive clogging during operations	Angle of attack too steep	Pull harrow sections from the other end
	Ground speed too low	Increase ground speed to 6 - 9 mph

BOLT TORQUE SPECIFICATIONS

Coarse Thread Series			Fine Thread Series		
Nut Size and Threads per Inch	Nut Tightening Torque (lb.ft.)		Nut Size and Threads per Inch	Nut Tightening Torque (lb.ft.)	
Grade C Nuts			Grade C Nuts		
	Max.	Min.		Max.	Min.
1/4 - 20	14.7	10	1/4 - 28	14.7	10
5/16 - 18	22.3	15.2	5/16 - 24	23.4	18.4
3/8 - 16	39	28	3/8 - 24	41	30
7/16 - 14	60	44	7/16 - 20	60	44
1/2 - 13	88	63	1/2 - 20	98	70
9/16 - 12	134	98	9/16 - 18	134	98
5/8 - 11	172	127	5/8 - 18	176	127
3/4 - 10	295	218	3/4 - 16	295	218
7/8 - 9	440	317	7/8 - 14	440	317
1 - 8	651	506	1 - 14	703	610

TIRE & LUG TORQUE SPECIFICATIONS

Tire Size	Ply Rating	Tire Pressure	Lug Size	Lug Tightening Torque (lb.ft.)	
				Max.	Min.
9.5L-15	8 ply	44 psi	½ x 1	85	75
11L-15	8 ply	36 psi	½ x 1	85	75

HDL-1024 through HDL-1038 HARROW CART (30° Hinge)
PARTS DIAGRAM

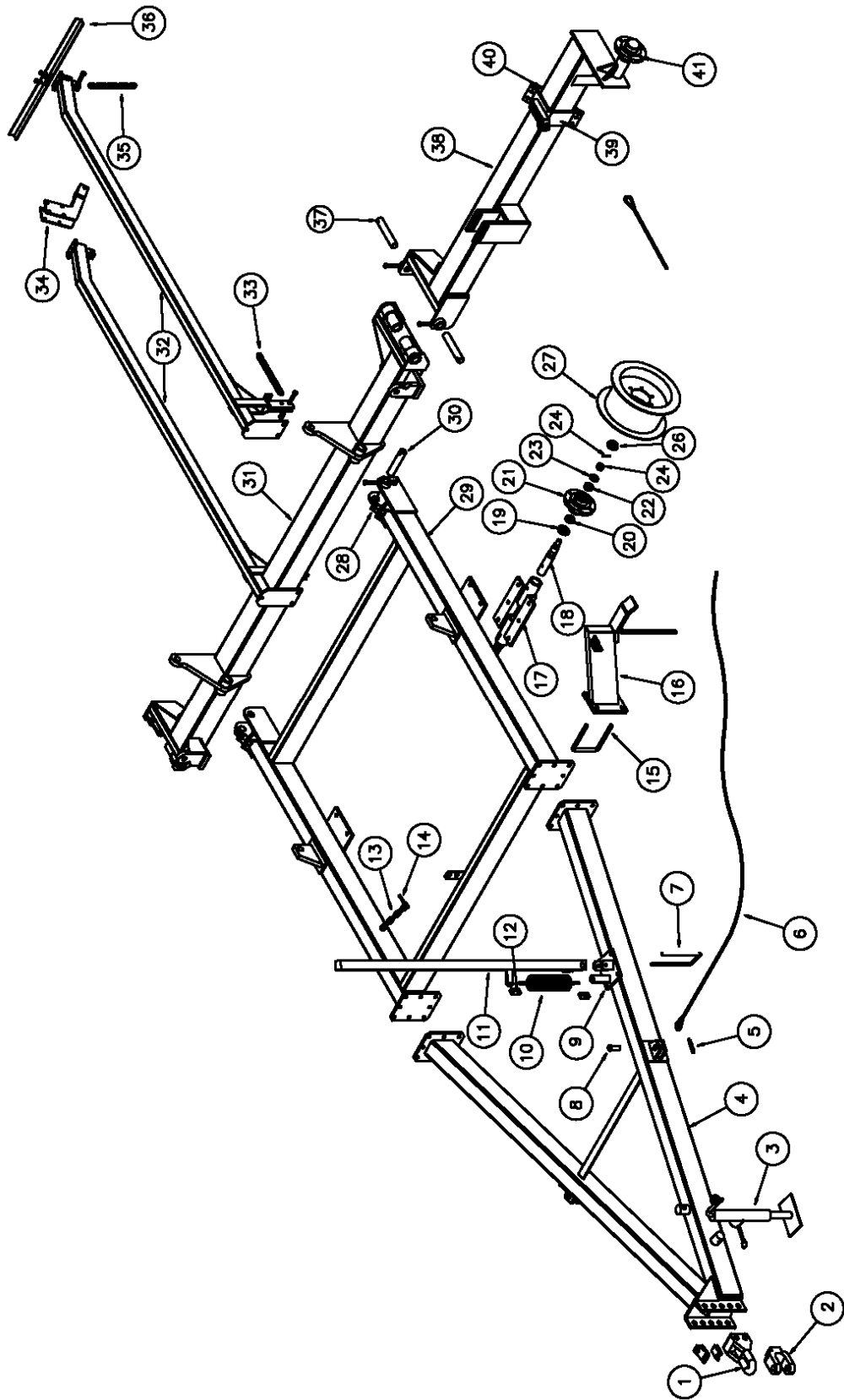

HDL-1024 through HDL-1038 HARROW CART (30° Hinge)**PARTS LIST**Always order by Part Number - *Not* by Key Number

KEY	PART #	DESCRIPTION	QTY.
1	PPI-200	BASE HITCH	1
2	PPI-208	CLEVIS	1
	PPI-201	HITCH CUSHION	1
	PPI-202	HITCH TOP PLATE, CAT II	1
	PPI-203	HITCH V-PLATE, CAT II-IV	1
3	HD-1151	JACK STAND (10")	1
4	HDL-2110	A-FRAME (HDL-1024 through HDL-1036)	1
	HDL-2120	A-FRAME (HDL-1038 only)	1
5	CP-3620	3/16" x 2" COTTER PIN	4
6	WC-8180	WING CABLE, HDL1024	2
	WC-2190	WING CABLE, HDL-1026/HDL-1028/HDL-1038	2
	WC-2195	WING CABLE, HDL-1030	2
	WC-2202	WING CABLE, HDL-1032 TO 1036	2
7	BU-1247	U-BOLT (1/2" x 4" x 7 1/4")	4
8	HD-1149	1" x 2 - 1/2" CLEVIS PIN	4
9	HDL-2540	CABLE LIFT ARM BASE (left hand)	1
**	HDL-2541	CABLE LIFT ARM BASE (right hand)	1
10	PH-10	CABLE LIFT ARM SPRING	2
11	HDL-2542	CABLE LIFT ARM ANGLE	2
12	DB-125	LOCK CLIP	4
13	CH-1415	CABLE LIFT CHAIN	2
14	AL-030	CABLE LIFT CHAIN ANCHOR SHACKLE	2
15	BU-5865	U-BOLT (5/8" x 6" x 5 1/2")	4
16	HDL-2522	WING REST (6")	2
17	WDL-2500	MAIN FRAME AXLE BRACKET	2
18	WDL-2505	AXLE SPINDLE	6
19	HD-1360	GREASE SEAL (6-hole hub)	6
20	HD-1362	INNER BEARING (6-hole hub)	6
21	HD-1361	HUB WITH RACES (6-hole hub)	6
22	HD-1363	OUTER BEARING (6-hole hub)	6
23	HD-1364	SPINDLE FLAT WASHER (6-hole hub)	6
24	HD-1365	SPINDLE HEX NUT (6-hole hub)	6
25	CP-1517	COTTER PIN	6
26	HD-1367	DUST CAP (6-hole hub)	6
27	HD-1370	RIM (15" x 6" 6-hole) for 9.5L-15 tire	*
	HD-1368	RIM (15" x 8" 6-hole) for 11L-15 tire	*
28	HDL-2201	SQUARE FRAME ADJUSTER BOLT	2
29	HDL-2210	HDL-1000 SQUARE FRAME	1
30	HDL-2714	CENTER BAR HINGE PIN (7 1/16")	2
31	HDL-2320	CENTER BAR ASSEMBLY	1

32	WDL-2620	8-BAR LIFT ARM	*
**	HDL-2535	4-BAR LIFT ARM	*
33	CH-0808	8-LINK PULL CHAIN	*
**	CH-0810	10-LINK PULL CHAIN	*
34	HDL-3300	REAR PULL POINT ASSEMBLY	*
35	CH-0808	8-LINK LIFT CHAIN	*
36		BRACE ANGLE (see layout diagram for part number)	*
37	SPR-2712	WING HINGE PIN (8 5/16")	4
38		WING FRAME (see layout diagram for part number)	1
39	HDL-2750	WING CABLE BRACKET (left hand)	1
**	HDL-2751	WING CABLE BRACKET (right hand)	1
40	HDL-2752	WING CABLE BRACKET CLAMP PLATE	2
41		SAME AS ITEMS 17 THROUGH 26	
**	DC-111	DECAL: "STAND CLEAR..."	1
**	DC-116	DECAL: "DO NOT CLIMB ON..."	1
**	DC-117	DECAL: "...USE JACK STAND"	1
**	DC-119	DECAL: "ESCAPING FLUID..."	1
**	HY-0310	HYDRAULIC BAG	1
**	HB-0312	FRAME HARDWARE BAG	1
**	BB-0310	FRAME BOLT BAG	1
**	BB-0315	8-BAR HARROW SECTIONS BOLT BAG	1
**	BB-0325	12 & 16-BAR HARROW SECTIONS BOLT BAG	1
**	BB-0335	4+4 & 8+8-BAR HARROW SECTIONS BOLT BAG	1
**	***	LITERATURE PACKET	1

-
- * Quantity depends on harrow sections used.
 - ** Unnumbered items are not pictured.
 - *** Please specify model number when ordering these parts.
 - xxx length in inches (84" is 084, 112" is 112)

Bolts, washers, nuts, and cotter pins are not shown. Refer to the step-by-step assembly instructions for details.

McFarlane Manufacturing reserves the right to change specifications of design at any time without obligation to modify previous products.

**FH-8-BAR HARROW SECTIONS
PARTS DIAGRAM & LISTING**

INCLUDES FH-500-8, FH-600-8, FH-700-8, FH-800-8, AND FH-900-8

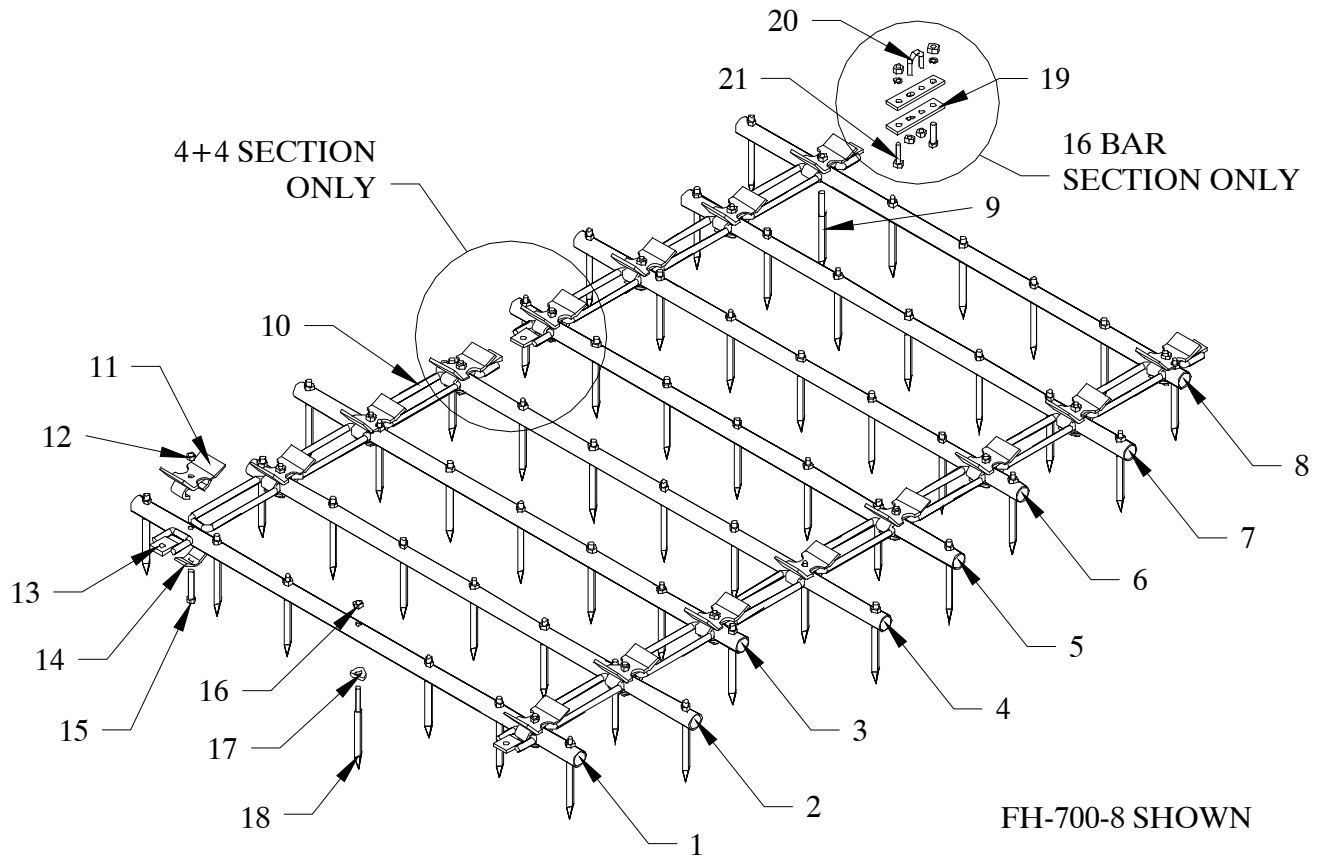

ITEM #	PART #	DESCRIPTION
1	FH-801	#1 HARROW BAR (FH-500-8)
1	FH-805	#1 HARROW BAR (FH-600-8)
1	FH-809	#1 HARROW BAR (FH-700-8)
1	FH-813	#1 HARROW BAR (FH-800-8)
1	FH-817	#1 HARROW BAR (FH-900-8)
2	FH-802	#2 HARROW BAR (FH-500-8)
2	FH-806	#2 HARROW BAR (FH-600-8)
2	FH-810	#2 HARROW BAR (FH-700-8)
2	FH-814	#2 HARROW BAR (FH-800-8)
2	FH-818	#2 HARROW BAR (FH-900-8)
3	FH-802	#3 HARROW BAR (FH-500-8)
3	FH-806	#3 HARROW BAR (FH-600-8)
3	FH-810	#3 HARROW BAR (FH-700-8)
3	FH-814	#3 HARROW BAR (FH-800-8)
3	FH-818	#3 HARROW BAR (FH-900-8)
4	FH-804	#4 HARROW BAR (FH-500-8)
4	FH-808	#4 HARROW BAR (FH-600-8)
4	FH-812	#4 HARROW BAR (FH-700-8)

4	FH-816	#4 HARROW BAR (FH-800-8)
4	FH-820	#4 HARROW BAR (FH-900-8)
5	FH-803	#5 HARROW BAR (FH-500-8)
5	FH-807	#5 HARROW BAR (FH-600-8)
5	FH-811	#5 HARROW BAR (FH-700-8)
5	FH-815	#5 HARROW BAR (FH-800-8)
5	FH-819	#5 HARROW BAR (FH-900-8)
6	FH-803	#6 HARROW BAR (FH-500-8)
6	FH-807	#6 HARROW BAR (FH-600-8)
6	FH-811	#6 HARROW BAR (FH-700-8)
6	FH-815	#6 HARROW BAR (FH-800-8)
6	FH-819	#6 HARROW BAR (FH-900-8)
7	FH-801	#7 HARROW BAR (FH-500-8)
7	FH-805	#7 HARROW BAR (FH-600-8)
7	FH-809	#7 HARROW BAR (FH-700-8)
7	FH-813	#7 HARROW BAR (FH-800-8)
7	FH-817	#7 HARROW BAR (FH-900-8)
8	FH-804	#8 HARROW BAR (FH-500-8)
8	FH-808	#8 HARROW BAR (FH-600-8)
8	FH-812	#8 HARROW BAR (FH-700-8)
8	FH-816	#8 HARROW BAR (FH-800-8)
8	FH-820	#8 HARROW BAR (FH-900-8)
9	E-611	1/2" x 3" SHANK SPIKE TOOTH ONLY
10	FH-125	CONNECTOR LINK (REGULAR)
11	FH-127	NOTCHED LINK CAP
12	**	1/2" LOCK NUT
13	FH-122	PULL FLAT
14	FH-019	CAP CLIP
15	**	1/2" x 3" BOLT
16	**	1/2" FLANGED LOCK NUT
17	E-630	SPIKE TOOTH WASHER
18	E-620	1/2" x 2 1/2" SHANK SPIKE TOOTH ONLY
**	E-610	1/2" x 2 1/2" SHANK SPIKE TOOTH w/WASHER
19	HDL-5100	DUAL SECTION CONNECTOR FLAT (16 BAR ONLY)
20	BV-7611	7/16" V-BOLT (16 BAR ONLY)
21	**	1/2" x 2" BOLT, LOCK WASHER AND NUT (16 BAR ONLY)
**	HDL-5101	DUAL SECTION CONNECTOR ASSEMBLY (16 BAR ONLY)

The #1 bar is the bar with an equal amount of tube to the right and left of the pull flats. The #8 bar is the bar that is staggered off to one side.

When pulling the harrow section from the #1 bar, the teeth will be in the least aggressive setting. When pulling from the #8 bar the teeth will be in the most aggressive setting.

9/24/08

**HDL-1024 through 1038 HARROW CART (30° Hinge)
HYDRAULICS DIAGRAM & LIST**

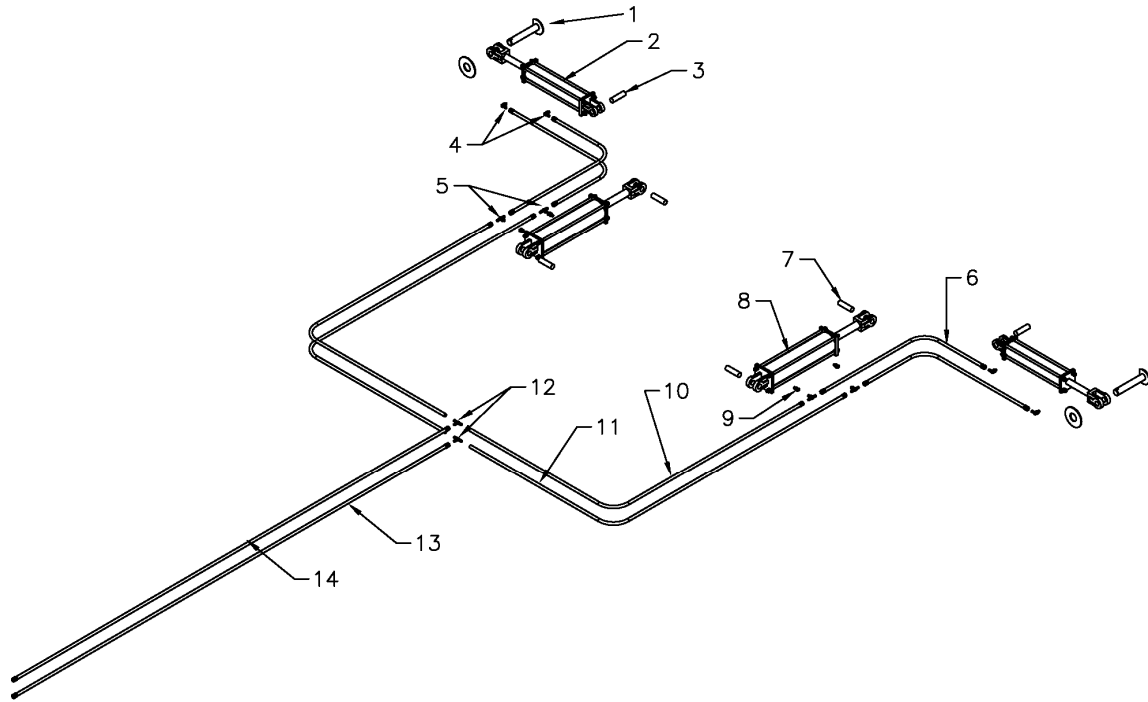

KEY	PART #	DESCRIPTION	QTY.
1	CL-1005	1" x 5" CLEVIS PIN	2
2	HYC-33014	3" x 14" HYDRAULIC CYLINDER	2
3	HYO-2103	1" x 3 1/2" CLEVIS PIN	2
4	HYF-2821	ELBOW w/restrictor (3/8"m – 1/2"o)	4
5	HYF-1808	TEE (3/8"m – 3/8"o - 3/8"m)	4
6	HYH-8054	3/8" x 54" HYDRAULIC HOSE	4
7	HYO-2123	1 1/4" x 3 1/2" CLEVIS PIN	4
8	HYA-33516	ASAE 3 1/2" x 16" HYDRAULIC CYLINDER	2
9	HYF-3301	ADAPTER (3/8" f o-ring - 1/2" m o-ring)	4
10	HYH-8084	3/8" x 84" HYDRAULIC HOSE	2
11	HYH-8108	3/8" x 108" HYDRAULIC HOSE	2
12	HYF-1888	TEE (3/8"m – 3/8"m - 3/8"m)	2
13	HYH-9180	3/8" x 180" HYDRAULIC HOSE with one 1/2" end	1
14	HYH-7180	3/8" x 180" HYDRAULIC HOSE w/restrictor & 1/2" end	1

Note: When ordering cylinder replacement parts, please specify cylinder make & part number.
McFarlane Manufacturing reserves the right to change specifications of design at any time without obligation to modify previous products.

HDL-1024 LAYOUT DIAGRAM

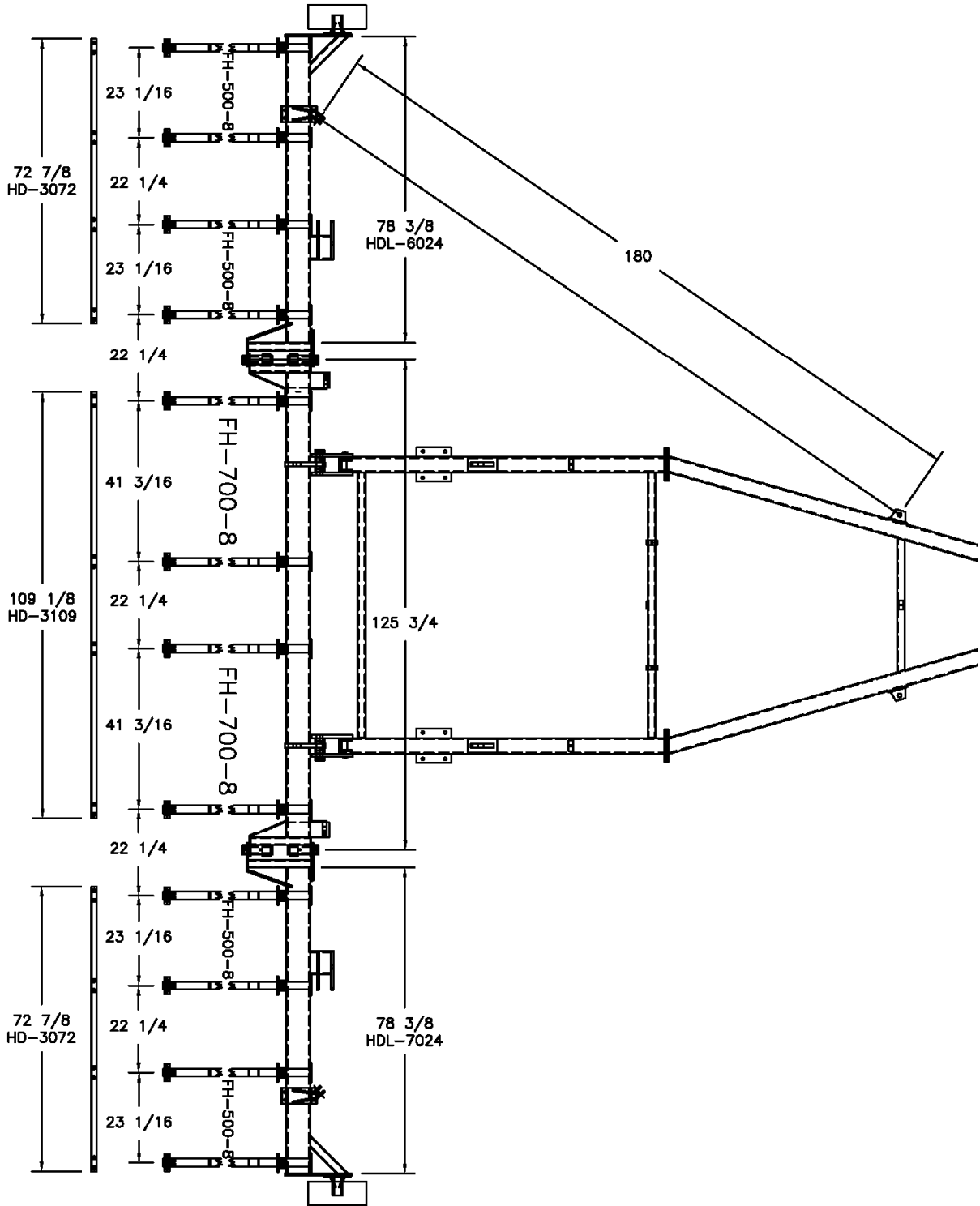

HDL-1026 LAYOUT DIAGRAM

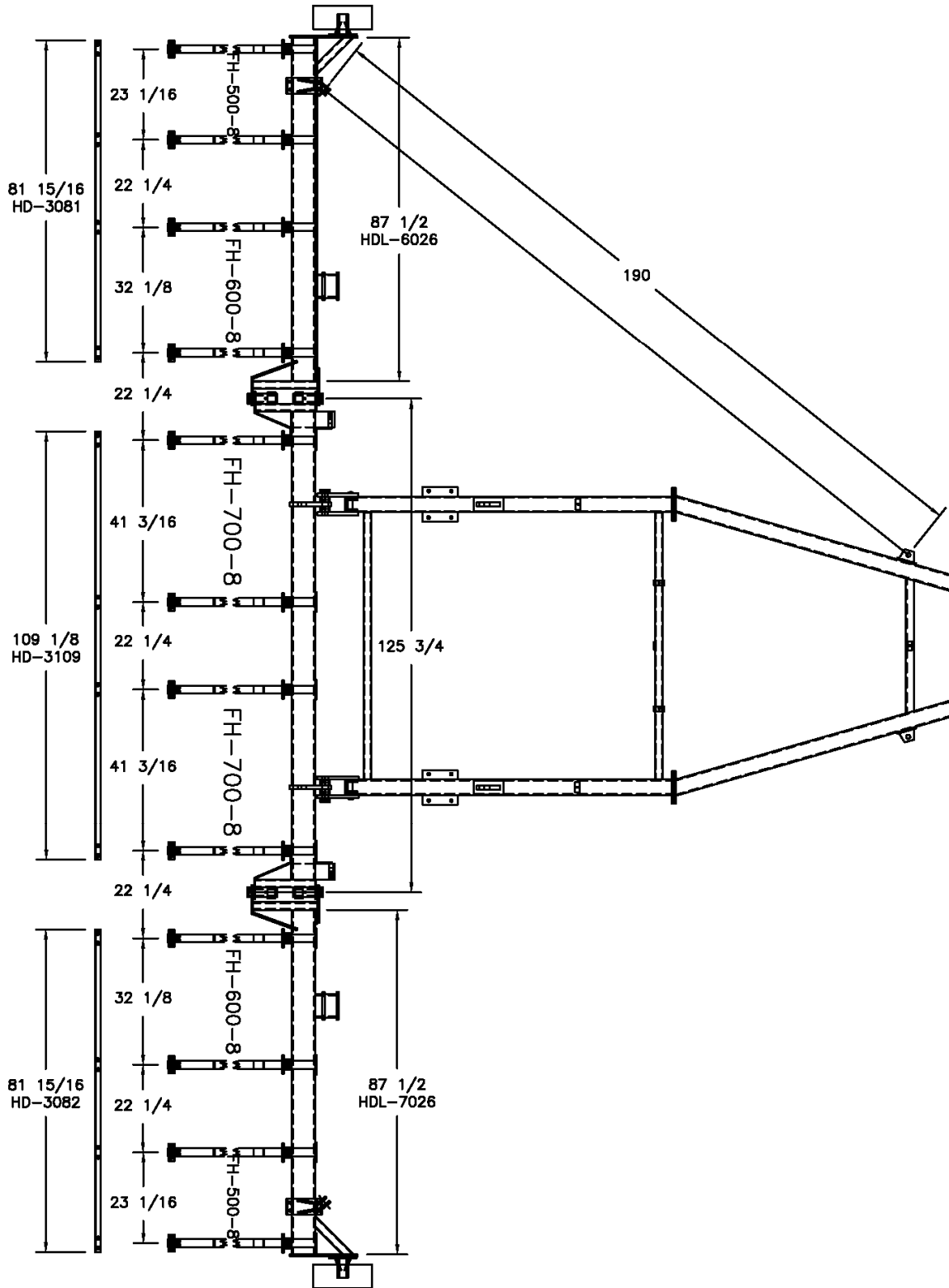

HDL-1028 LAYOUT DIAGRAM

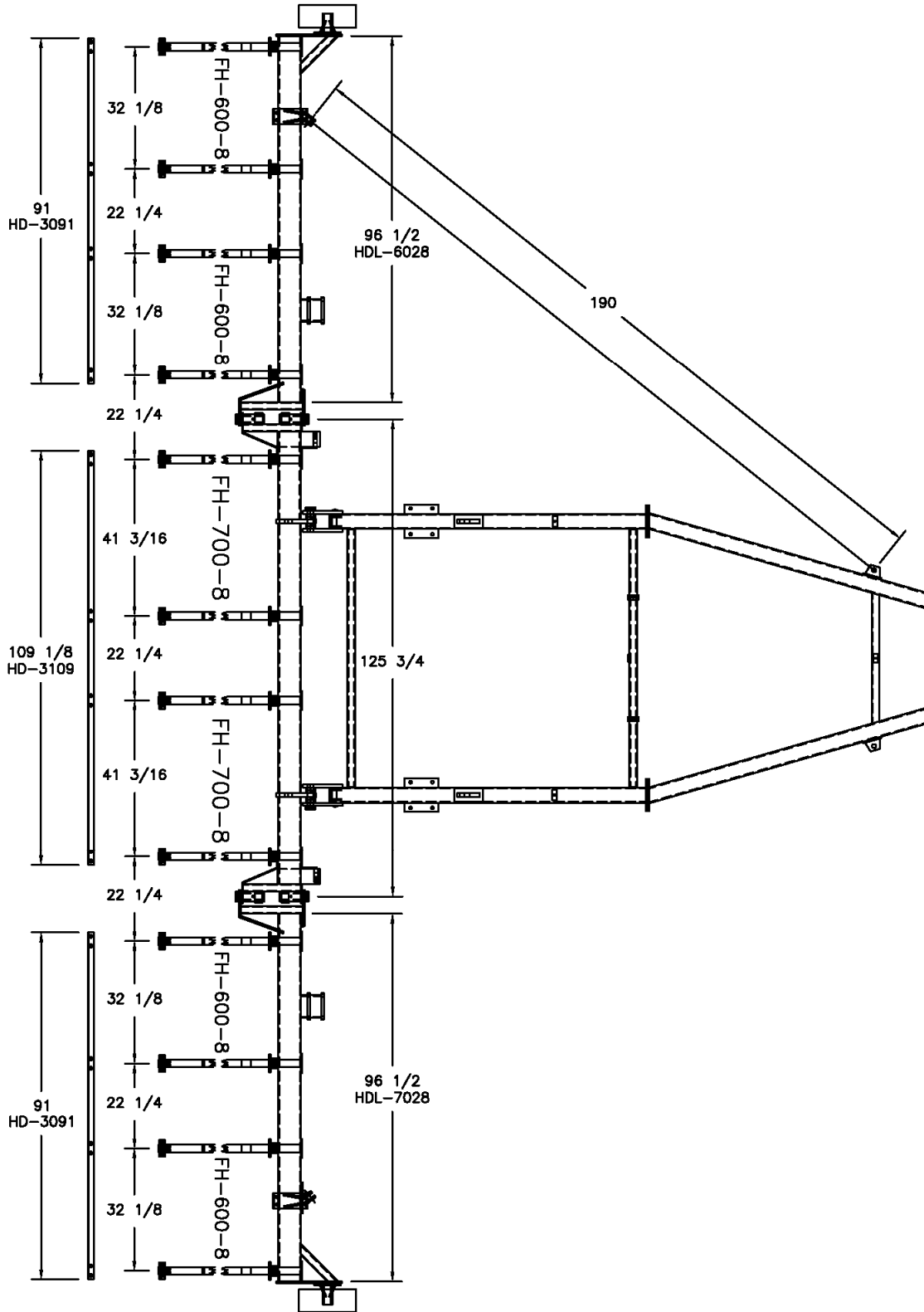

HDL-1030 LAYOUT DIAGRAM

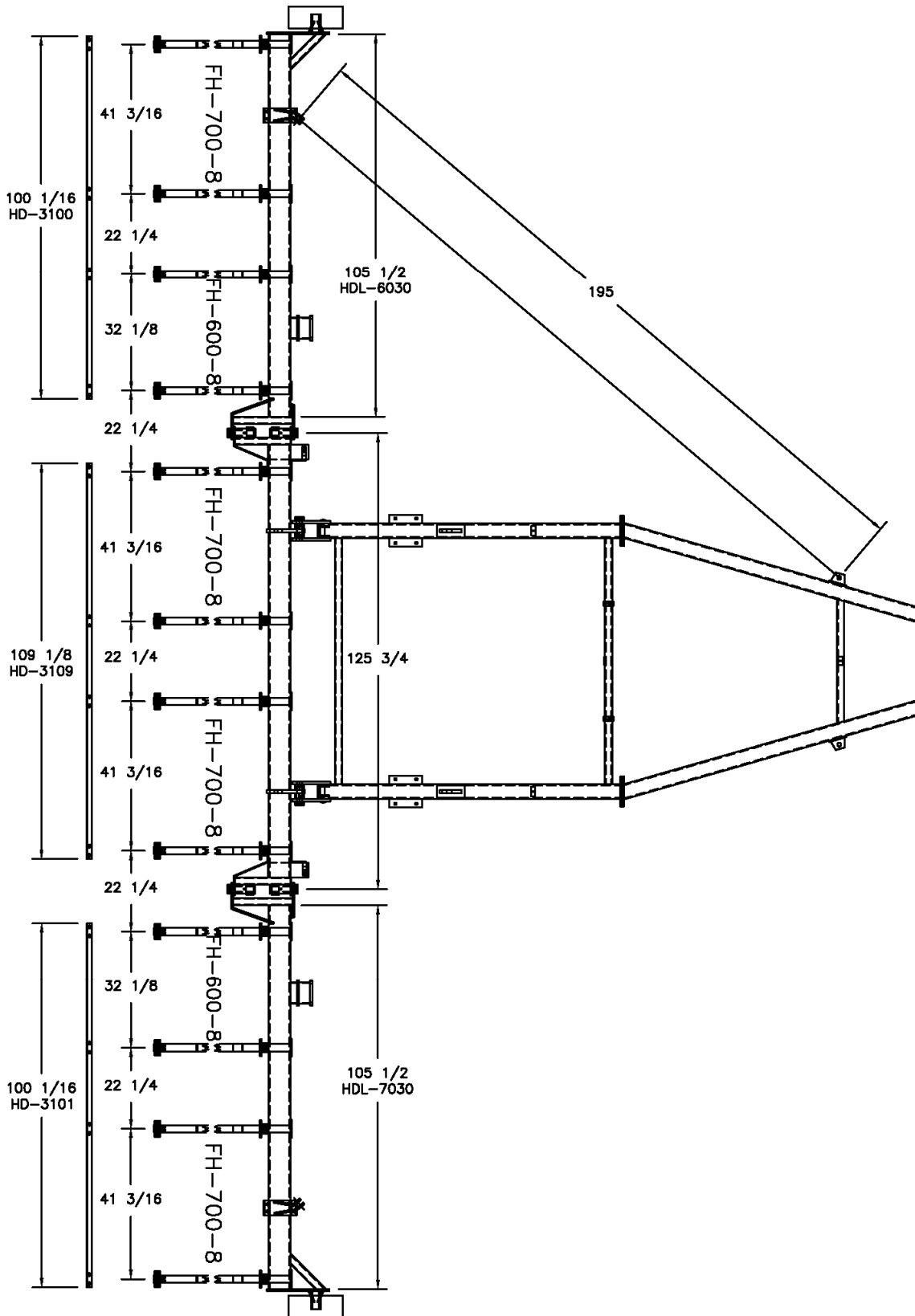

HDL-1032 LAYOUT DIAGRAM

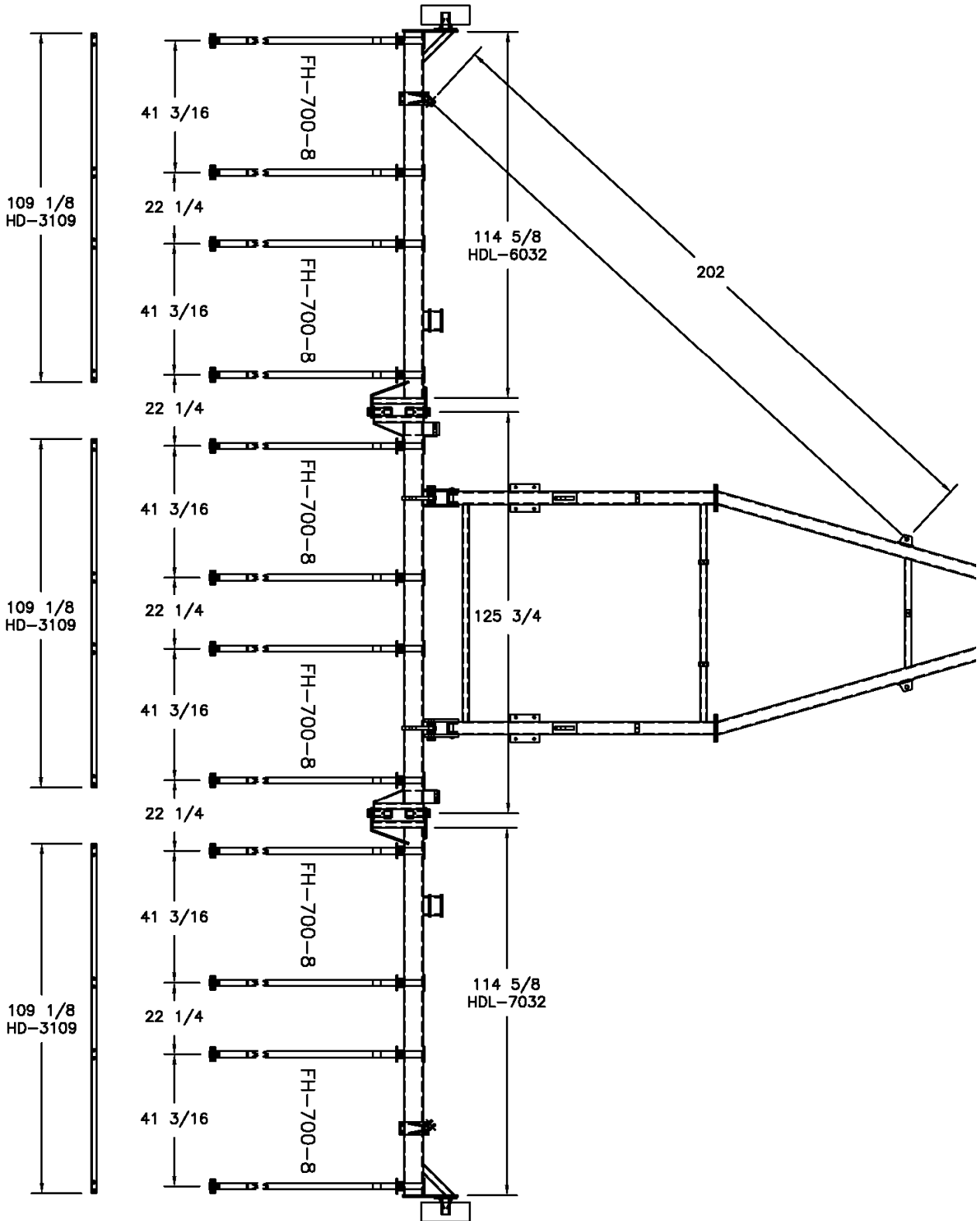

HDL-1034 LAYOUT DIAGRAM

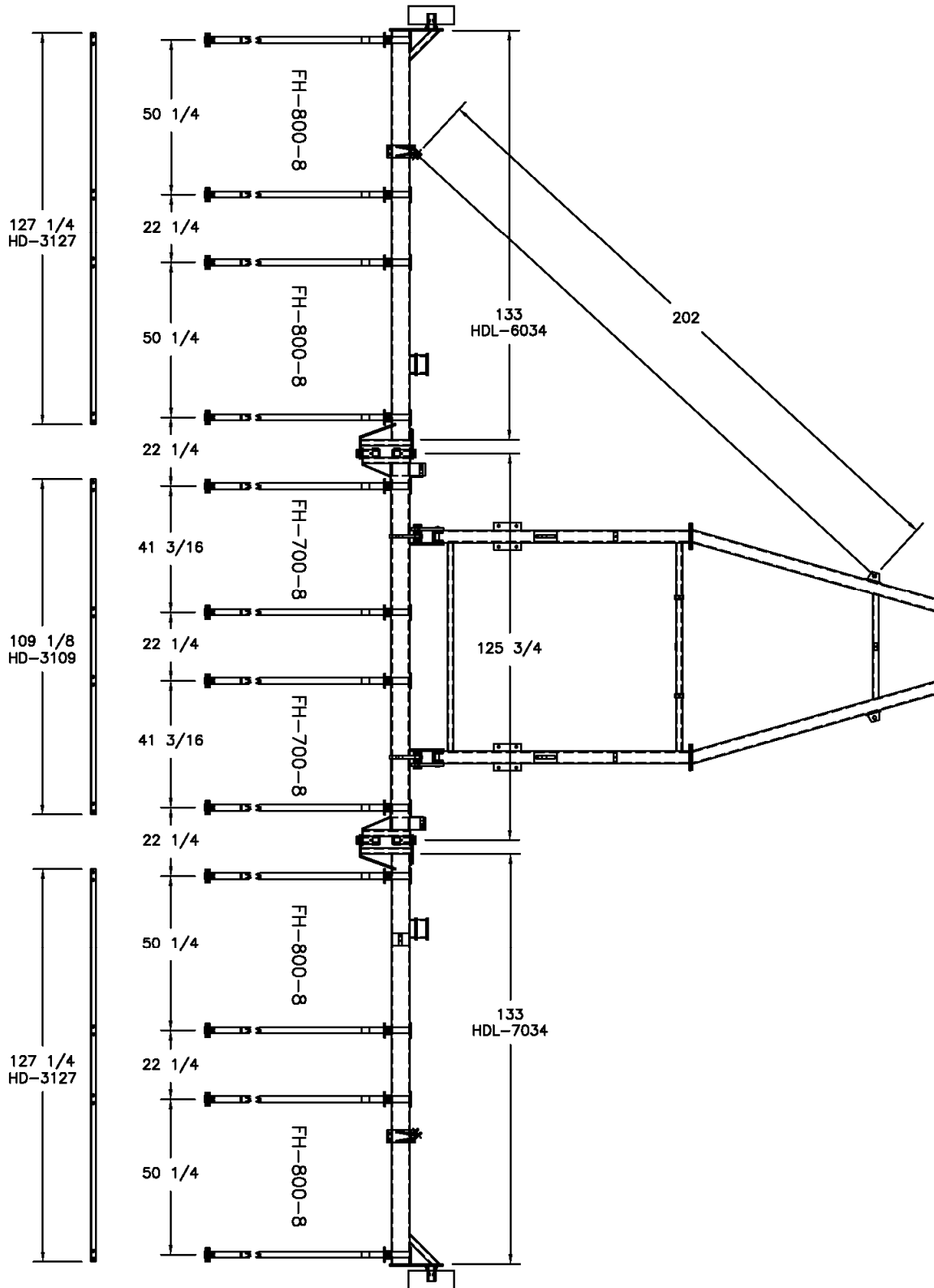

HDL-1036 LAYOUT DIAGRAM

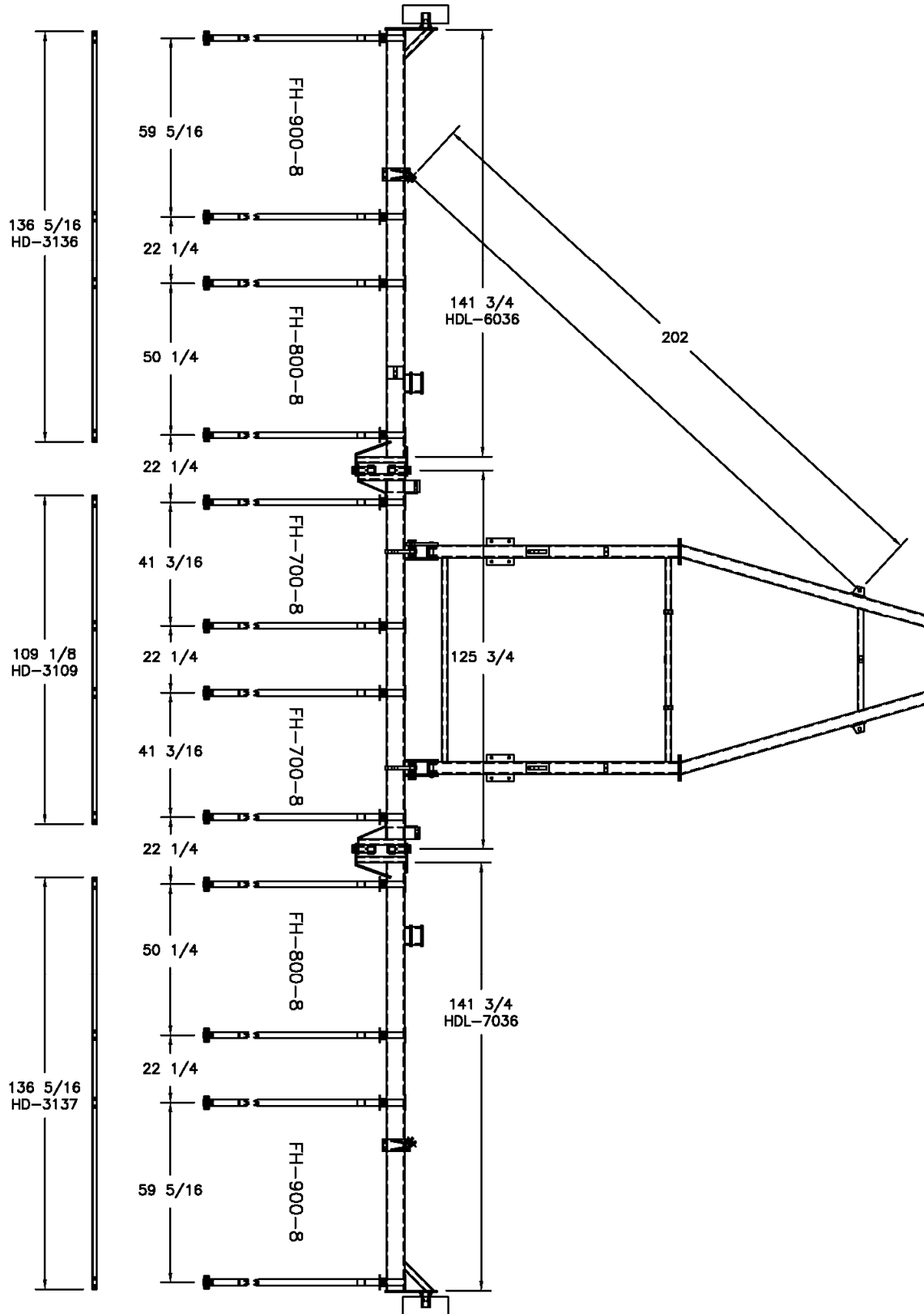

HDL-1038 LAYOUT DIAGRAM

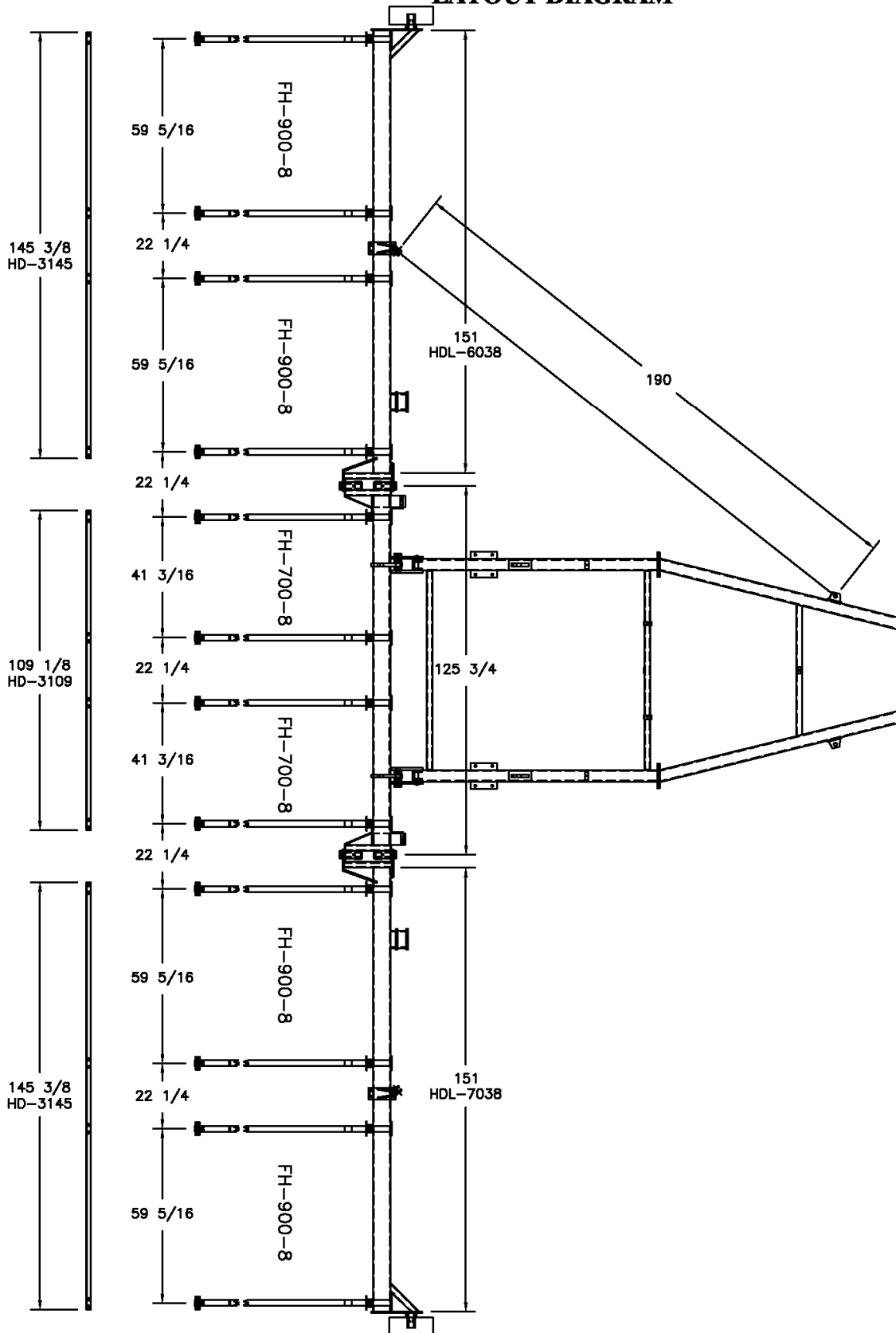

WARRANTY REGISTRATION FORM

This form must be filled out by the dealer and owner and sent to: McFarlane Mfg. Co., Inc., 1330 Dallas Street, P.O. Box 100, Sauk City, WI 53583.

WARRANTY REGISTRATION FORM & INSPECTION REPORT

WARRANTY REGISTRATION

This form must be filled out by the dealer and signed by both the dealer and customer at the time of delivery.

Customer Name _____ Dealer Name _____

Address _____ Address _____

City, state, code _____ City, state, code _____

Phone number (____) _____

Model _____ Serial Number _____ Delivery Date _____

DEALER INSPECTION REPORT

_____ Wheel bolts tight
_____ Fasteners tight
_____ Hydraulic hoses free
_____ Hydraulic fittings tight
_____ Arms free
_____ Check tire pressures
_____ Lubricate machine

SAFETY

_____ All decals installed
_____ Review operating and safety instructions

I have thoroughly instructed the buyer on the above described equipment; review included the operator's manual content, equipment care, adjustments, safe operation and applicable warranty policy.

Date _____ Dealer's signature _____

The above equipment and operator's manual have been received by me and I have been thoroughly instructed as to care, adjustments, safe operation, and applicable warranty policy.

Date _____ Owner's signature _____