

BOOM MOWERS - LARGE HP



HOW TO CHOOSE THE RIGHT BOOM MOWERS FOR YOUR NEEDS

		Tractors HP												
		20	25	30	35	40	50	60	70	80	90	100	110	120
Ferri range for USA	T250A		██████████	██████████	██████████									
	T320A		██████████	██████████	██████████	██████████								
	T380D					██████████	██████████							
	T430D						██████████	██████████	██████████					
	T460						██████████	██████████	██████████					
	TM46 Farm						██████████	██████████	██████████					
	TP51 Farm								██████████	██████████	██████████			
	TP61 Farm									██████████	██████████	██████████		
	TXV50										██████████	██████████	██████████	
	TXV60											██████████	██████████	██████████

Which are the environmental conditions requested?

1	A	Verges - side of the road (no need for very long reach)	The all range can be suitable
	B	Banks - ditches - canals (need for long reach)	TP-TXV provided that the reach requested is form min. 16'

Mowing conditions ?

2	A	grass up 20" big	TM farm - TP - TXV	What thickness?	up to 2"	T - TM Farm - TP
	B	grass more than 20" big				
		bushes				
		shrubs				
		branches				
wood	up to 2" 1/4"	TXV				

How often will the boom mower be used?

3	A	short periods per year (6 -12 weeks) few hours per day (up to 4 hours)
	B	short periods per year (6 -12 weeks) several hours per day (8 -12 hours)
	C	long periods per year (4 - 6 months) several hours per day (8 -12 hours)

Our answer	AAA	T - TM Farm	no oil cooler	
	AAB	T - TM Farm - TP	with oil cooler	
	AAC	TXV	with oil cooler	
	ABA	TM Farm - TP - TXV	no oil cooler	Depending on thickness
	ABB	TM Farm - TP - TXV	with oil cooler	Depending on thickness
	ABC	TXV	with oil cooler	
	BAA	TP	no oil cooler	
	BAB	TP	with oil cooler	
	BAC	TXV	with oil cooler	
	BBA	TP - TXV	no oil cooler	Depending on thickness
	BBB	TXV	with oil cooler	
	BBC	TXV	with oil cooler	

HP 49 available to the rotor
HP 63 max to hydraulic motor



SIMPLY. THE MOWER

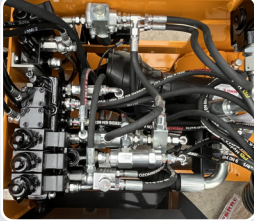

High Power Gear hydraulic system.



Oil cooler with thermostat.



Rear mounted flailhead with rack and pignon gear to ensure the most precise cutting position.

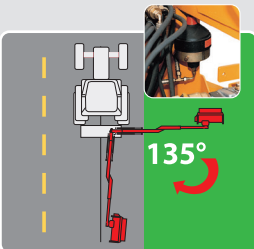

Hydraulic breakaway with accumulator controlled autoreset facility (SRA).



PROFESSIONAL BOOM MOWERS FOR MUNICIPAL GROUNDS MAINTENANCE



Two-section proportional electrical control. With CAN-Bus technology.

The SC (Speed Criteria) Dual control gives you the ability to select different boom operating modes depending on the type of work you need to do. The joystick controls the proportional function of the first and second booms. Power slew and flail head rotation are proportional functions driven by "roller" controls on the joystick.

HP Tractor	80	90	100	110	Min. tractor weight lbs	Min. tractor width ft.
TXV 50					7500	6'9"
TXV 60					8000	7'6"

Working positions

	TXV 50	TXV 60
A	ft 17.19	20.51
A1	ft 15.39	18.21
A2	ft 7.91	7.91
B	ft 16.96	20.11
C	ft 13.25	16.47
D	ft 10.17	13.06
E	ft 15.58	18.86
I	ft 8.40	9.61
L	ft 4.59	4.92
M	ft 8.01	9.68
N	ft 8.79	8.79
O	ft 9.15	10.86
P	ft 4.82	4.82
Q	ft 4.92	4.92
R	ft 9.25	10.86
S	30°	30°

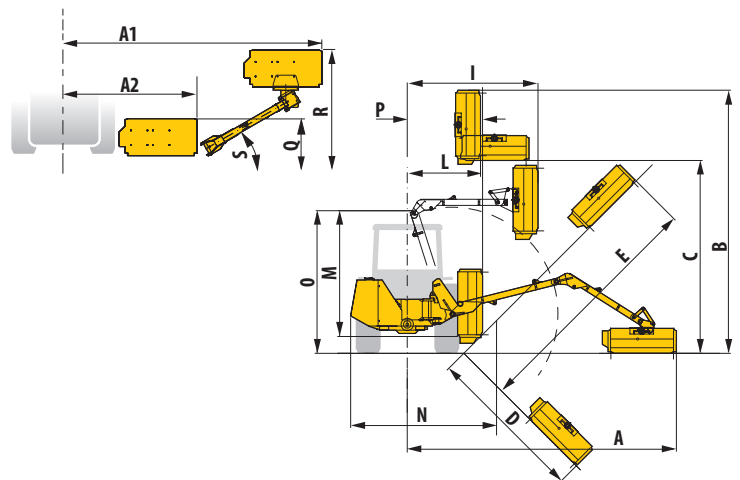

TECHNICAL DATA

Model	Max horizontal reach* ft.	Weight lbs	Three point linkage Cat.	Oil gal	Rotor Rpm	Pto MAX Rpm	Flail head angle
TXV50 Energy	15'5"-17'2"	2756	II	55	3000	540	230°
TXV60 Energy	18'2"-20'6"	2855	II	55	3000	540	230°

* Reach measured from tractor centre line to head edge

MACHINES WITH ELECTRO-HYDRAULIC PROPORTIONAL CONTROLS "SC-TRONIC Dual"

Model		Suggested Retail - \$
TXV50 Energy with flail head TNI 125	A	59.819
TXV50 Energy with flail head TNI 125	G	60.188
TXV60 Energy with flail head TNI 125	A	62.028
TXV60 Energy with flail head TNI 125	G	62.424

COMPLETING EQUIPMENT TO THE BASE MACHINE AT EXTRA CHARGE

WARNING: due to the high offset loads on the linkages it is necessary to fit two stabilizers	Length Inch.	Suggested Retail - \$
1 Top link (cod. TGA5018)	13" - 18"	378
1 set of short stabilizers recommended with Delta Bracket (cod. TSN5033)	18 1/2" - 28 1/4"	537
1 Top link (cod. TGA5019)	19" - 28"	378
1 set of standard stabilizers to the tractor (cod. TGA5020)	27" - 35"	274
Delta Bracket (cod. OPT001121000)		598

OPTION AT AN EXTRA CHARGE

	Suggested Retail - \$
Rear axle rigid fitting system recommended for TXV60 (cod. ARK200)	5.525

FLAIL HEAD

	TNI 125
Width (ft)	3'10"
Rotor speed (rpm)	3000
Blade tip speed (ft/sec)	196
Flail head angle	230°
Weight (lbs)	573





TNI 125
Direct drive

DOMEX®
HIGH STRENGTH STEEL

Flails TNI 125

With dedicated rotor

"Y" flails for grass, shrubs Ø max 1,18 i	Reinforced rotating hammers for wood, brushwood Ø max 2,36 i
 A	 G
Cod. 0901209	Cod. 0901213
52	18

- Due to transport in containers, big models like TP61 and TXV will be supplied partially disassembled. Reassembling as per Ferri instruction booklet will be at dealers charge
- Attachment to the tractor 3 point hitch will also be at dealer's charge. It includes: fitting of the "delta bracket" and adaption of the stabilizers to the tractor 3 point hitch, fitting of the controls in the cabine and Pto shaft fitting.
- Lift float kit and the oil cooler kit could be shipped with the machine but not mounted. In which case the mounting according to Ferri Owner's manual instruction will be at dealer's charge.



SIMPLY. THE MOWER

Equipped with:

- Flail head
- Totally independent hydraulic system
- FLOATING head system
- Worm gearbox "HP" (high performance) high torque transmission
- Hydraulic break-back with accumulator controlled autoreset facility
- 129° power slew
- Oil cooler with thermostat
- Front and rear abrasion resistant guard for flail head
- Pressure relief valve kit for rack on flail head
- Lift float kit
- Oil and pto shaft

WARNING



It is RECOMMENDED that you connect the equipment to the tractor and start it up for the first time together with your Dealer, following the instructions and paying attention to the warnings indicated in our use and maintenance manual. If you require further information, please contact our after sales service.

