

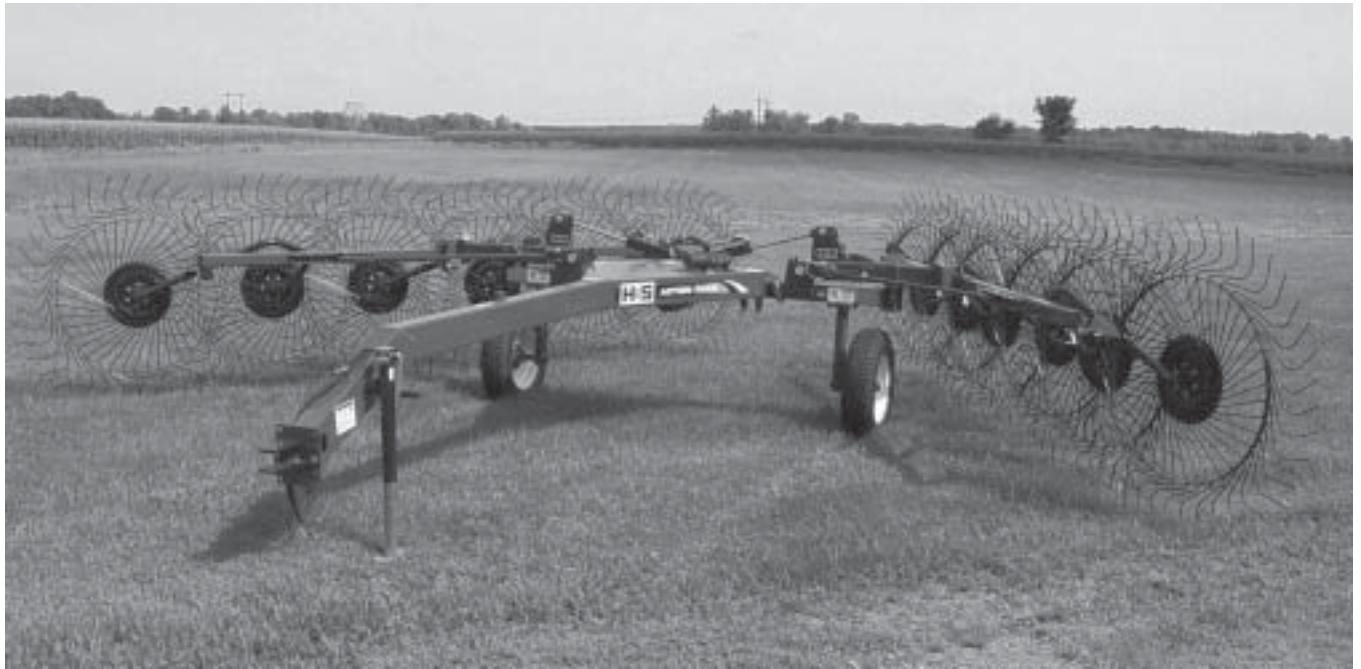

AR08 - AR10 - AR12 ACTION RAKES



READ AND UNDERSTAND THIS MANUAL BEFORE OPERATING THIS EQUIPMENT.

UNSAFE OPERATION OR MAINTENANCE OF THIS EQUIPMENT CAN RESULT IN SERIOUS INJURY OR DEATH.

OPERATOR'S MANUAL AND PARTS LIST

Revision #1

AR08 Starting Serial #212016

AR10 Starting Serial #214020

AR12 Starting Serial #216019

HSMFG0112

Manufactured By
H&S MANUFACTURING CO., INC.

P.O. BOX 768 (715) 387-3414 FAX (715) 384-5463
MARSHFIELD, WISCONSIN 54449

H&S AR8 - AR10 - AR12 Rakes
OPERATOR'S & PARTS MANUAL

CONTENTS

Warranty & Warranty Registration Card.....	1-2
Dealer Pre-Delivery & Delivery Checklist.....	3-6
Be Alert Symbol.....	7
Explanation of Safety Signs.....	8
Danger - Warning Signs.....	9
Warning - Owner Must Read and Understand.....	10
Bolt Torque Chart.....	11
Set-Up & Assembly.....	12
Preparing for Operation.....	13
Transporting.....	14
Operation & Adjustments.....	15-17
Options & Features.....	18
Lubrication Guide.....	19-20
Decal Location & Identification.....	21-23
Troubleshooting Guide.....	24
Instructions for Ordering Parts - About Improvements.....	25
Parts.....	26-34
Parts Notes.....	35-36

WARRANTY

H&S WARRANTY

H&S Manufacturing Co., Inc. ("H&S") warrants this product to be free from defect in material and workmanship. Except as noted below, this warranty term is twelve (12) months from the date of delivery of the product to the original purchaser by an authorized H&S dealer. Under this warranty, H&S will repair or replace, at its option, any covered part which is found to be defective in material or workmanship during the applicable warranty term. In no case will the covered repair cost of a part or parts exceed the replacement cost of that part. Warranty service must be performed by H&S or a dealer authorized by H&S to sell and/or service the product involved, which will use only new or remanufactured parts or components furnished by H&S. This warranty includes approved parts and labor to fix the product but does not include, and the purchaser is responsible for, any service call and/or transportation of the product to and from the dealer's place of business, for any premium charged for overtime labor requested by the purchaser, and for any service work not directly related to any defect covered under this warranty. This warranty includes only those components of the product manufactured by H&S. Warranty for any component not manufactured by H&S including, but not limited to, engines, batteries, tires, rims, hydraulic motors, pumps, etc. are covered by the warranty, if any, provided separately by their respective manufacturers.

This warranty in all its parts, is extended solely to the original purchaser of the product, is terminated upon any subsequent transfer or sale from or by the original purchaser and extends no third party benefits or rights whatsoever.

The warranty term for any product used in any commercial, custom, for hire or rental application, is limited to six (6) months from the date of delivery of the product to the original purchaser by an authorized H&S dealer.

Polybonded (polyethylene and plywood) panels utilized in H&S Manure Spreaders are warrantied, to the original purchaser, to not wear through and the polyethylene overlay to not tear free of the plywood for the functional life of the spreader. This specific warranty on polybonded panels includes only replacement of any defective panel part without any allowance for labor beyond the terms of the general warranty (12 or 6 months), and is further limited to manure spreaders used to spread normal agricultural manure.

This warranty does not include: (1) Any product that has been altered or modified in ways not approved by H&S; (2) Depreciation or damage caused by normal wear, misuse, improper or insufficient maintenance, improper operation, accident or failure to follow the product Operator's Manual recommendations and product decal recommendations; (3) Normal maintenance parts and service; (4) Repairs made with parts other than those available from H&S or performed by anyone other than H&S or a dealer authorized by H&S to sell and/or service the product involved.

To secure warranty service the purchaser must report the product defect to a dealer authorized by H&S to sell and/or service the product involved within the applicable warranty term together with evidence of the warranty start date and make the product available to that dealer within a reasonable period of time.

THERE ARE NO WARRANTIES WHICH EXTEND BEYOND THE DESCRIPTION ON THE FACE OF THIS WARRANTY. H&S and the companies affiliated with it makes no warranties, representations, or promises, express or implied, as to the performance or freedom from defect of its products other than those set forth above and **NO IMPLIED WARRANTY OF MERCHANTABILITY, FITNESS OR FITNESS FOR A PARTICULAR PURPOSE IS MADE. IN NO EVENT WILL THE DEALER, H&S OR ANY COMPANY AFFILIATED WITH H&S BE LIABLE FOR INCIDENTAL OR CONSEQUENTIAL DAMAGES.** The **ONLY REMEDY** the purchaser has in connection with the breach of performance of any warranty on H&S products are those set forth above.

The selling dealer has no authority to make any representation or promise on behalf of H&S, or to modify the terms or limitations of this warranty in any way.

2/04

WARRANTY REGISTRATION

Date of Purchase _____

Purchaser _____ Address _____

City _____ State _____ Zip _____

Product _____ Model# _____ Serial# _____

Dealer _____ Address _____

City _____ State _____ Zip _____

Signature of Original Buyer

**FILL OUT AND MAIL
IMMEDIATELY TO MAKE
WARRANTY EFFECTIVE**



IMPORTANT!

Tear on dotted line, provide the information requested on the card. The H&S Warranty is valid **“only”** after this card is received and recorded at H&S Mfg. Co. Mail at once. No postage is required in the U.S.A.



NO POSTAGE
NECESSARY
IF MAILED
IN THE
UNITED STATES

BUSINESS REPLY MAIL
FIRST CLASS MAIL Permit No. 195 Marshfield, WI 54449

POSTAGE WILL BE PAID BY ADDRESSEE

H&S Manufacturing Co., Inc.
PO Box 768
Marshfield WI 54449-9963



H&S DEALER PRE-DELIVERY CHECK LIST

AFTER COMPLETION, DEALER SHOULD REMOVE AND RETAIN FOR RECORDS

After the rake has been completely set-up, check to be certain it is in correct operating order before delivering to the customer. The following is a list of points to inspect. Check off each item as you have made the proper adjustments and found the item operating satisfactorily.

- Rake was not damaged in shipment. Check for dents and loose or missing parts. Report damage immediately to H&S Manufacturing Co., Inc.
- Rake has been correctly assembled according to instructions in this manual. Wheel nuts and all other fasteners are tightly secured.
- All bolts and fasteners are tight.
- All grease fittings have been lubricated. See Lubrication Chapter of this manual for details.
- Hoses and fittings are properly attached and there are no visible leaks.
- All mechanisms are operating trouble free.
- Rake wheels touch ground in unison when lowered into position. (Rake setting level)
- Wheels are properly mounted.
- Tires are inflated to correct pressure.
- Decals are in place and legible.

Model Number _____

Serial Number _____

Dealer's Name _____

Inspection Date _____

Signature of Pre-Delivery Inspector _____

(Remove Dealers File Copy At Perforation)

Intentionally Left Blank

DEALER DELIVERY CHECK LIST

AFTER COMPLETION, DEALER SHOULD REMOVE AND RETAIN FOR RECORDS

This check list that follows is an important reminder of valuable information that should be passed on to the customer at the time this Rake is delivered.

Check off each item as you explain it to the customer.

This delivery check list, when properly filled out and signed assures the customer that the Pre-delivery service was satisfactorily performed.

- Explain to the customer that the pre-delivery inspection was made.
- Explain to the customer all the safety precautions they must exercise when operating this unit.
- Explain raking and windrow width adjustments.
- Explain to customer that regular lubrication is required for proper operation and long life of machine.
- Show customer the lubrication section of Owner's Manual.
- Give the customer Owner's Manual and make sure they read and understand all operating and service instructions.
- Record Serial Number on page 25 of this Manual.
- Have the customer sign a completed "Warranty Registration", and mail it.

Date Delivered _____

Dealer's Name _____

By _____

Signature of Original Buyer _____

Note: Warranty is not valid until warranty card is completed and returned to H & S Mfg. Co., Inc.

Intentionally Left Blank

SAFETY INFORMATION



**BE
ALERT!**

**YOUR SAFETY
IS INVOLVED.**

THIS SYMBOL IS USED THROUGHOUT THIS BOOK WHENEVER YOUR PERSONAL SAFETY IS INVOLVED. TAKE TIME TO BE CAREFUL. REMEMBER: THE CAREFUL OPERATOR IS THE BEST OPERATOR. MOST ACCIDENTS ARE CAUSED BY HUMAN ERROR. CERTAIN PRECAUTIONS MUST BE OBSERVED TO PREVENT THE POSSIBILITY OF INJURY OR DAMAGE.

TRACTORS

This operator's manual uses the term "Tractor" when identifying the power source.

H & S MANUFACTURING CO., INC.

SAFETY INFORMATION

RECOGNIZE SAFETY INFORMATION

This is the safety-alert symbol. When you see this symbol on your machine or in this manual, be alert to the potential for personal injury.

Follow recommended precautions and safe operating practices.



UNDERSTAND SIGNAL WORDS

A signal word- DANGER, WARNING, or CAUTION - is used with the safety-alert symbol. DANGER identifies the most serious hazards.

Safety signs with signal word DANGER or WARNING are typically near specific hazards.

General precautions are listed on CAUTION safety signs.



WARNING



CAUTION



FOLLOW SAFETY INSTRUCTIONS

Carefully read all safety messages in this manual, and all safety signs on your machine. Follow all recommended precautions and safe operating procedures.

Keep signs in good condition. Immediately replace any missing or damaged signs.

OBSERVE MAXIMUM TRANSPORT SPEED

The maximum transport speed for this implement is 32 km/h (20 m.p.h.).

Some tractors are capable of operating at speeds that exceed the maximum transport speed of this implement. Regardless of the maximum speed capability of the tractor being used to tow this implement, do not exceed the implement's maximum transport speed.

Exceeding the implements maximum transport speed can result in:

- * Loss of control of the tractor/implement combination
- * Reduced or no ability to stop during braking
- * Implement tire failure
- * Damage to the implement structure or its components

Use additional caution and reduce speed when towing under adverse surface conditions, when turning, and when on inclines.

Do not attempt transport if the fully loaded implement weighs more than 1.5 times the weight of the tractor.



SAFETY INFORMATION

	<p style="text-align: center;">⚠ WARNING</p> <p style="text-align: center;">STAY CLEAR OF RAKE WHEN RAISING OR LOWERING RAKE WHEELS.</p> <p style="text-align: center;">FAILURE TO HEED THIS WARNING MAY RESULT IN <u>PERSONAL INJURY OR DEATH.</u></p> <p style="text-align: center;">KEEP CLOTHING, YOURSELF AND OTHERS WELL CLEAR.</p> <p style="text-align: right; font-size: small;">2700A</p>
---	--

<p style="text-align: center;">⚠ WARNING</p> <p style="text-align: center;">STAY CLEAR OF RAKE WHEN RAISING OR LOWERING RAKE WHEELS.</p> <p style="text-align: center;">FAILURE TO HEED THIS WARNING MAY RESULT IN <u>PERSONAL INJURY OR DEATH.</u></p> <p style="text-align: center;">KEEP CLOTHING, YOURSELF AND OTHERS WELL CLEAR.</p> <p style="text-align: right; font-size: small;">2700B</p>

	<p style="text-align: center;">⚠ WARNING</p> <p style="text-align: center;">CLOSE HYDRAULIC LOCKING VALVE FOR SERVICE, TRANSPORT, OR WHEN RAKING WITH ONE SIDE.</p> <p style="text-align: center;">FAILURE TO HEED THIS WARNING MAY RESULT IN PERSONAL INJURY OR DEATH.</p> <p style="text-align: right; font-size: small;">DC31811</p>
---	--

⚠ WARNING		
		
<p>CRUSHING HAZARD</p> <p>TO PREVENT SERIOUS INJURY OR DEATH:</p> <p>KEEP HANDS AND BODY OUT OF HITCH AREA WHEN ATTACHING TOWING VEHICLE.</p> <p>KEEP BODY CLEAR OF CRUSH POINT BETWEEN TOWING VEHICLE AND LOAD.</p> <p>KEEP FEET AND LEGS CLEAR FROM UNDER TONGUE AREA IN CASE OF POSSIBLE JACK FAILURE.</p> <p style="text-align: right; font-size: x-small;">82302</p>		

	<p style="text-align: center; background-color: #cccccc;">⚠ WARNING</p> <p style="text-align: center;">DO NOT GO NEAR LEAKS</p> <ul style="list-style-type: none"> • High pressure oil easily punctures skin causing serious injury, gangrene or death. • If injured, seek emergency medical help. Immediate surgery is required to remove oil. • Do not use finger or skin to check for leaks. • Lower load or relieve hydraulic pressure before loosening fittings. <p style="text-align: right; font-size: x-small;">11599</p>
--	---

⚠ WARNING	
	<p style="font-size: 2em; margin: 0;">STAY CLEAR</p> <p style="text-align: right; font-size: small; margin-top: 10px;">1906C</p>

⚠ WARNING	
HELP AVOID INJURY	
<ul style="list-style-type: none"> • READ & UNDERSTAND THE OPERATORS MANUAL PROVIDED WITH THIS MACHINE. IF MISPLACED CALL H & S MANUFACTURING AT 715-387-3414 WITH MODEL AND SERIAL NUMBER. • UNDERSTAND ALL SAFETY WARNINGS AND FUNCTION OF CONTROLS. • KEEP SAFETY DEVICES IN PLACE AND WORKING. • KEEP YOURSELF AND OTHERS WELL CLEAR OF MOVING PARTS. • DISCONNECT ALL POWER BEFORE SERVICING OR CLEANING THIS MACHINE. • DO NOT EXCEED 20 MPH 	
72203A	

TRACTORS

This operators manual uses the term “Tractor” when identifying the power source.



WARNING

TO PREVENT SERIOUS INJURY OR DEATH

BEFORE YOU ATTEMPT TO OPERATE THIS EQUIPMENT, READ AND STUDY THE FOLLOWING INFORMATION. IN ADDITION, MAKE SURE THAT EVERY INDIVIDUAL WHO OPERATES OR WORKS WITH THIS EQUIPMENT, WHETHER FAMILY MEMBER OR EMPLOYEE, IS FAMILIAR WITH THESE SAFETY PRECAUTIONS.

DO NOT ALLOW PERSONNEL OTHER THAN THE QUALIFIED OPERATOR NEAR THE MACHINE.

Stop the tractor engine, remove ignition key, and allow all mechanisms to stop before cleaning, working, or adjusting on machine.

IF RAKE ARMS ARE IN THE RAISED POSITION, MAKE SURE THE HYDRAULIC TRANSPORT LOCK VALVES TO LOCK THE RAKE ARMS ARE IN THE CLOSED POSITION BEFORE CLEANING, WORKING ON, OR ADJUSTING MACHINE.

DO NOT attempt to perform maintenance or repair with tractor running.

DO NOT step up on machine at any time.

DO NOT allow minors to operate or be near the machine.

Stay clear of rake when raising or lowering main rake beams.

Stay clear of hydraulic lines, they may be under extreme pressure or heat.

For transport and storage, always make sure that the transport lock valves are in the closed position.

H&S Manufacturing always takes the operator and his safety into consideration and guards exposed moving parts for their protection. However, some areas cannot be guarded or shielded in order to assure proper operation. In addition, the operators manual and decals on the machine itself warn you of further danger and should be read and observed closely.

Study The Above Safety Rules

ATTENTION - BE ALERT - YOUR SAFETY IS INVOLVED

CAP SCREW TORQUE VALUES

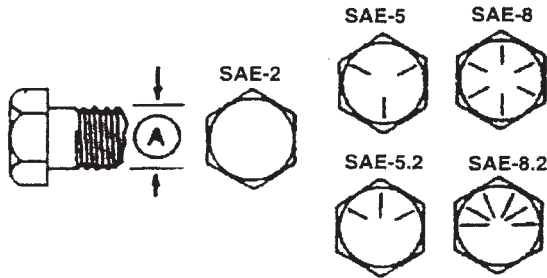

Inch Cap Screw Head Markings

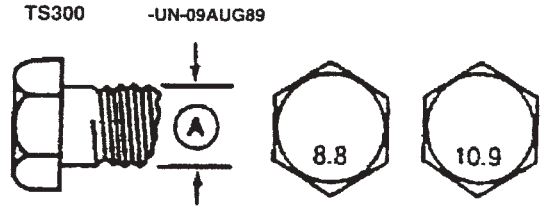

Metric Cap Screw Head Markings

INCH CAP SCREW TORQUE VALUES

Bolt Diameter (A)	Wrench Size	Cap Screw Grade					
		SAE 2		SAE 5		SAE 8	
		N-m	lb.-ft	N-m	lb.-ft	N-m	lb.-ft
1/4"	7/16"	7	(5)	11	(8)	16	(12)
5/16"	1/2"	14	(10)	23	(17)	33	(24)
3/8"	9/16"	24	(18)	41	(30)	54	(40)
7/16"	5/8"	41	(30)	68	(50)	95	(70)
1/2"	3/4"	61	(45)	102	(75)	142	(105)
9/16"	13/16"	88	(65)	142	(105)	203	(150)
5/8"	15/16"	122	(90)	197	(145)	278	(205)
3/4"	1-1/8"	217	(160)	353	(260)	495	(365)
7/8"	1-5/16"	224	(165)	563	(415)	800	(590)
1"	1-1/2"	332	(245)	848	(625)	1193	(880)
1-1/4"	1-7/8"	665	(490)	1492	(1100)	2393	(1765)

METRIC CAP SCREW TORQUE VALUES

Bolt Diameter (A)	Wrench Size	Markings on Cap Screw Heads			
		8.8		10.9	
		N-m	lb.-ft	N-m	lb.-ft
5 mm	8 mm	6	(4.5)	9	(6.5)
6 mm	10 mm	10	(7.5)	15	(11)
8 mm	13 mm	25	(18)	35	(26)
10 mm	16 mm	50	(37)	75	(55)
12 mm	18 mm	85	(63)	130	(97)
16 mm	24 mm	215	(159)	315	(232)
20 mm	30 mm	435	(321)	620	(457)
24 mm	36 mm	750	(553)	1070	(789)
30 mm	46 mm	1495	(1103)	2130	(1571)



CAUTION: Use only metric tools on metric hardware. Other tools may not fit properly. They may slip and cause injury.

DO NOT use these values if a different torque value tightening procedure is listed for a specific application. Torque values listed are for general use only. Check tightness of cap screws periodically.

Shear bolts are designed to fail under predetermined loads. Always replace shear bolts with identical grade. Fasteners should be replaced with the same or higher grade. If higher grade fasteners are used, these should only be tightened to the strength of the original.

Make sure fastener threads are clean and you properly start thread engagement. This will prevent them from failing when tightening.

Tighten plastic insert or crimped steel-type lock nuts to approximately 50 percent of amount shown in chart. Tighten toothed or serrated-type lock nuts to full torque value.

SET-UP & ASSEMBLY

NOTE: Determine right or left side of the wheel rake by viewing it from the rear. If instructions or parts lists call for hardened bolts, refer to bolt torque chart.

1. Assemble the rake or check the rake for proper assembly and adjustment. Make sure that all bolts are tightened.
2. Attach the wheels with tires, using the lug nuts furnished and torque the mounting hardware to 95 ft./lbs. of torque. Check wheel bolts periodically thereafter.
3. Check tires and inflate to the recommended pressure. (ST205/75R15 - 50 PSI)
4. Lubricate the rake completely (See Lubrication Chapter in This Manual).
5. Tooth bolts must be torqued to 40 ft./lbs. to help prevent excessive tooth breakage.
Re-torque rake tooth bolts after the first 100 acres. Check periodically thereafter.

PREPARING FOR OPERATION

ADJUSTMENTS

There are 5 sets of holes on the adjustable hitch. In addition, the hitch can also be flipped upside down to obtain 5 more positions, for a total of 10 positions to adjust for levelness. The hitch should be adjusted so the main rake beams are level, or parallel to the ground when in the raking position.

1. Adjust the tractor hitch (13 to 17 inches above ground) and attach rake to tractor with a **hitch pin that has a safety locking device.**

2. Remove weight from lift jack.
Place jack in the storage position.



3. Connect the 2 hydraulic hoses for raising and lowering rake arms to the tractor. Open the 2 hydraulic transport lock valves and operate the tractor valve to fill the hydraulic lines and operate the cylinders. Add hydraulic fluid to the tractor system, as required. After the rake arms have returned to the transport position, close the transport lock valves before transporting.



4. Retighten all bolts on rake after 100 acres as bolts can loosen up on new machinery.
5. **Re-torque rake tooth bolts after first 100 acres. Check periodically thereafter.**

TRANSPORTING

TRANSPORT LOCKS

There are two hydraulic transport lock valves on the rake that must be turned to the closed position during transport in case of tractor valve leakage, or hose breakage.

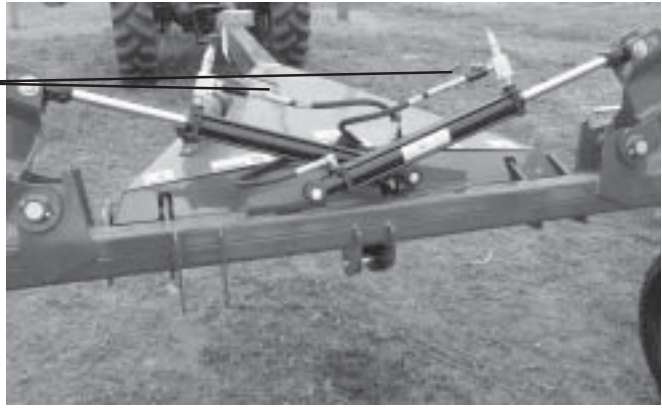

TOWING ON HIGHWAY

Follow state and local regulations when towing farm equipment on public highways. Never tow the rake on a public highway at a speed greater than 20 m.p.h. (32 kph).



REFLECTORS

Front amber & rear red reflective decals on the outer edges of the rake for safety.

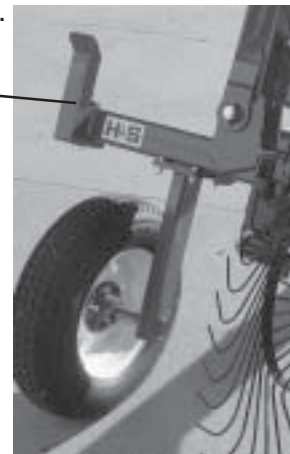
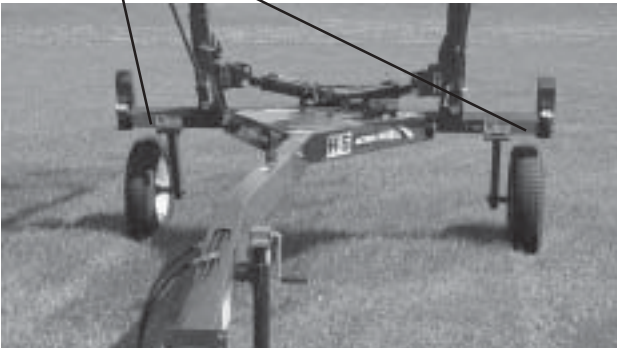

OPERATION & ADJUSTMENTS

EMERGENCY SHUTDOWN

Stop the tractor engine, remove ignition key, and allow all mechanisms to stop before cleaning or working on the machine.

TRANSPORT LOCKS

Before the rake arms can be hydraulically lowered for raking, the two hydraulic transport lock valves on the rake that must be turned to the open position.

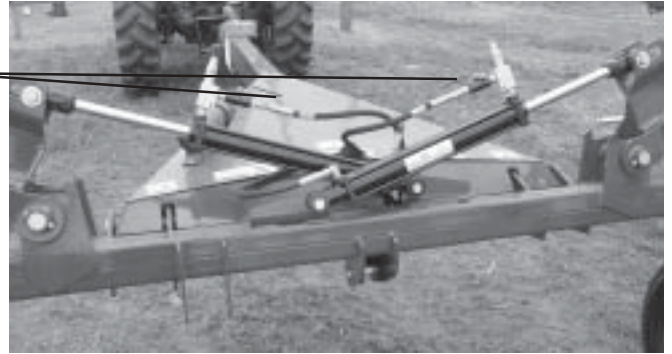

RAKING WIDTH ADJUSTMENT

The AR08 rake has six width adjustments on each rake beam. The AR10 and AR12 have ten width adjustments on each rake beam. Each rake beam angle can be adjusted independently for multiple raking conditions. The front hole is typically used as a transport position.

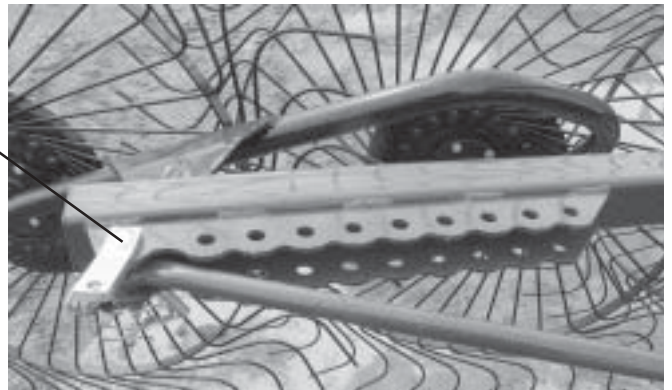

AR10/AR12 WINDROW WIDTH ADJUSTMENT

Remove the jack from jack storage position. Position jack mount tube on top of rake beam pin with jack foot in position as shown. Remove the pin and clip from the rake arm.

Windrow width can now be adjusted on each side of the rake. The AR10 and AR12 have two adjustments. After the desired windrow width has been reached, re-insert pin in desired hole, remove jack and return to the storage position.

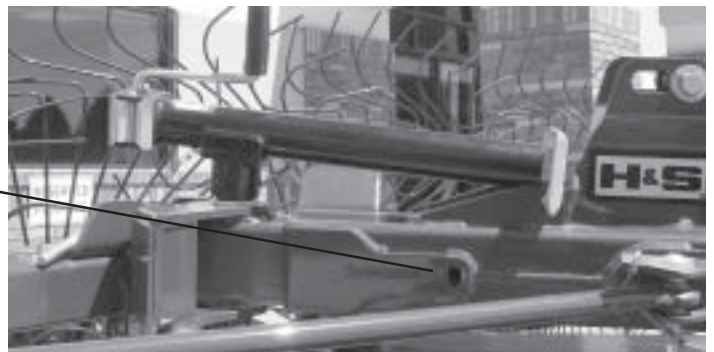

OPERATION & ADJUSTMENTS

HYDRAULIC SYSTEM

The ACTION Rake utilizes a 2 hose hook-up with a Master/Slave cylinder system. When the rake arms are lowered, the axles rotate forward, raising the main frame for more clearance. When the rake arms are raised, the axles rotate rearward, lowering the main frame for transport. This system is incorporated with the raising and lowering of the rake arms.

Cylinder Raking Position



Cylinder Transport Position



FLOATATION

Rake Arm

Floatation pressure of the rake arms can be adjusted by adjusting the stop on the top of the spring located at each end of the main frame. The stop should be adjusted so there is approximately 1/4" of threads showing above the jam nut. The rake can be adjusted for lighter floatation by "raising" the stop.

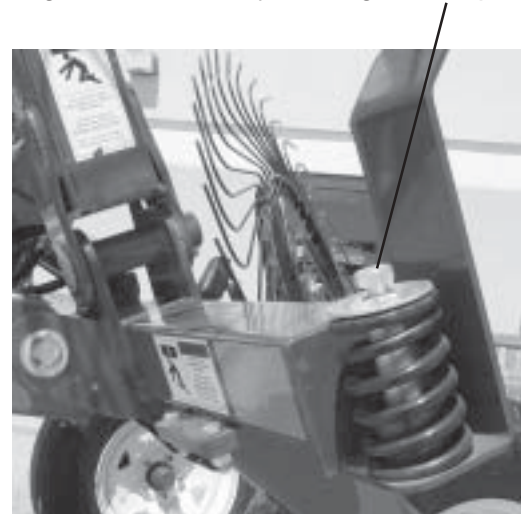
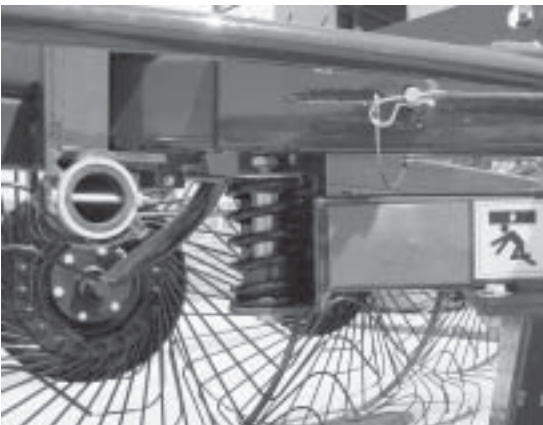

OPERATION & ADJUSTMENTS

FLEXIBILITY

Rake Arm

The rake has been designed that when the rake is lower on level ground, the pins of the cylinder are centered in the bracket of the rake. This allows the rake beams to flex up and down without the hydraulic cylinder restricting it's motion. The rake arms are also on a pivot to allow oscillation for additional floatation.

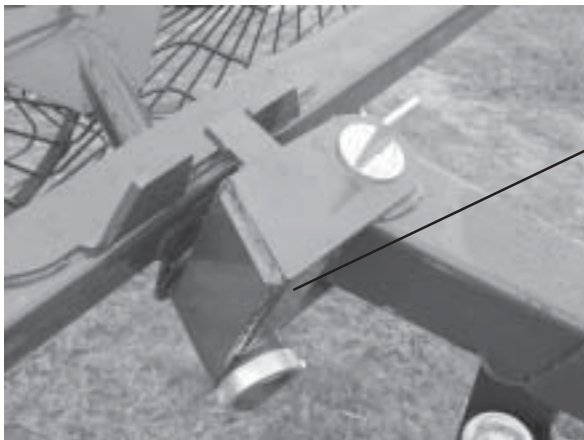

Rake Beam

The rake beam is allowed to oscillate through the main arm pin for added floatation.

Rake Wheel

Rake wheel oscillation is achieved through the wheel arm mount pin with the slotted style hole.



ONE SIDED RAKING

Raking with one side can be accomplished by closing either of the transport lock valves when the rake is in the transport position. When the tractor remote hydraulic valve is operated, only the rake arm with the hydraulic transport lock valve in the open position will lower into the raking position. The rake arm with the hydraulic transport lock valve in the closed position will stay in the transport position.

OPTIONS

CENTER KICKER WHEEL

An optional center kicker wheel is available for the AR10 & AR12 rakes. If the hay is laying out flat, the extra wheel allows you to raise the hay laying in the center of the rake out of the stubble for easier pick-up. The center kicker wheel will raise and lower when the hydraulics are activated.

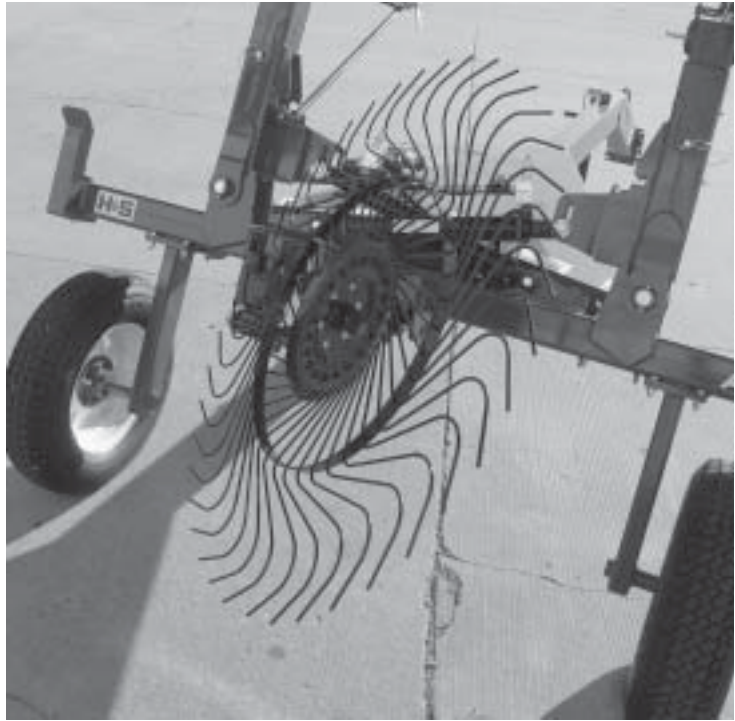

LUBRICATION

Become familiar with all lubrication points and establish a routine to ensure complete lubrication of the rake.

GENERAL INFORMATION

IMPORTANT: *Catch and dispose of fluid per local waste disposal regulations whenever service is performed on hydraulic components, valves, cylinders, hoses, etc.*

WHEEL BEARING LUBRICATION, CLEAN & RE-PACK INSTRUCTIONS

Grease wheel bearings as needed depending on amount of travel.

Annually disassemble and clean parts in a solvent. Pack bearings with a high grade grease. Reassemble, and tighten nut until a slight drag is felt when wheel is turned. Back nut off and insert cotter pin into first hole that you see as you back the nut off, bend cotter pin over and re-install cap.

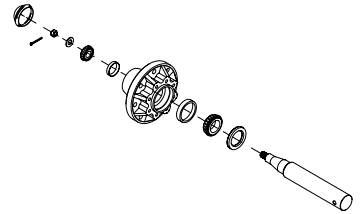

GREASE FITTINGS

There are 16 grease fittings on the AR08, 20 on the AR10/AR12 model rakes, and 1 on the Center Kicker Wheel. If lubricated properly and often enough, it will prolong the life of your rake. Grease daily during normal use and before and after storage and after power washing. Use a good grade of high quality grease. Make sure that grease comes out around the shaft on sleeve type bearings. Wipe off excessive grease to prevent accumulation of chaff or grit around the bearing. Replace any missing or plugged grease fittings.

LOCATION

Listed and shown are the description of location and number of grease fittings.

Zerk
Center kicker wheel
arm (If Equipped)

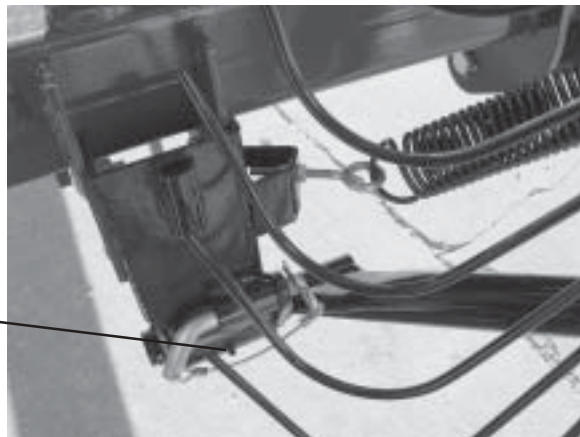

LUBRICATION

Rake Beam - One on each pivot & double rake wheel arm



One on each ACTION pivot (bottom)

One on each vertical pivot point, rake arm mount

Four on each lift arm (top & bottom)

One on each lift arm pivot point

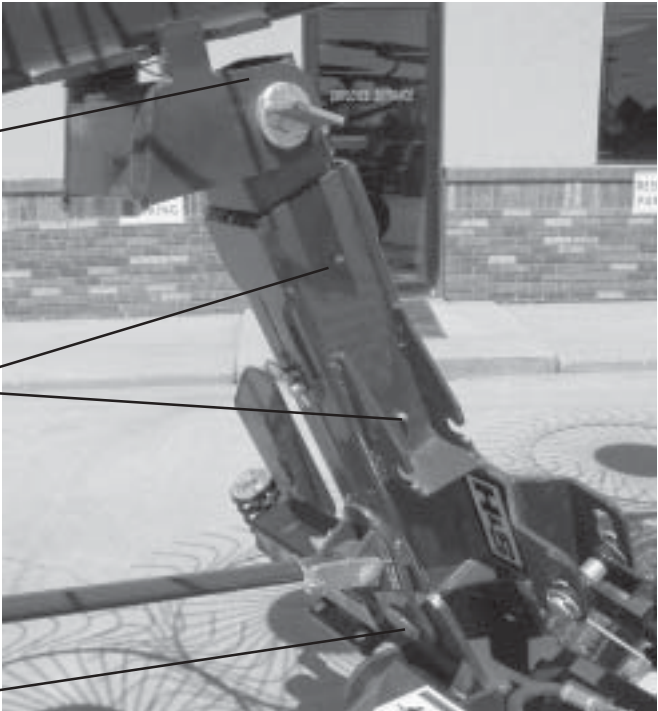

DECAL PLACEMENT

Your H&S Rake was manufactured with operator safety in mind. Located on the rake are various decals to aid in operation, and warn of caution areas. Pay close attention to all decals.



DO NOT REMOVE ANY OF THESE DECALS. IF DECALS ARE LOST, DAMAGED, OR IF CARTED WHEEL RAKE IS REPAINTED, REPLACE DECALS. REMEMBER: DECALS ARE FOR YOUR PROTECTION AND INFORMATION.

Listed below are the decals on your Rake.

<u>Part #</u>	<u>Quantity</u>	<u>Description</u>
1906C	2	Stay Clear
2700A	2	Stay Clear of Rake
2700B	2	Stay Clear of Rake
11599	1	Do not go near leaks
72203A	1	Help avoid injury - Read and understand the operators manual
82602	2	Crushing Hazard
71188B	1	Jack Storage Position
DC31811	2	Close Hydraulic Locking Valve
B6DC	2	H&S Decal
8496	1	H&S Decal 3 x 6
8497	1	AR8 Decal
8501	1	AR10 Decal
8505	1	AR12 Decal
8495	1	Action Rake Decal - Right
8494	1	Action Rake Decal - Left
311	1	Patent Decal
DCAMB1	2	Amber Reflector
DCRED	2	Red Reflector

DECAL PLACEMENT

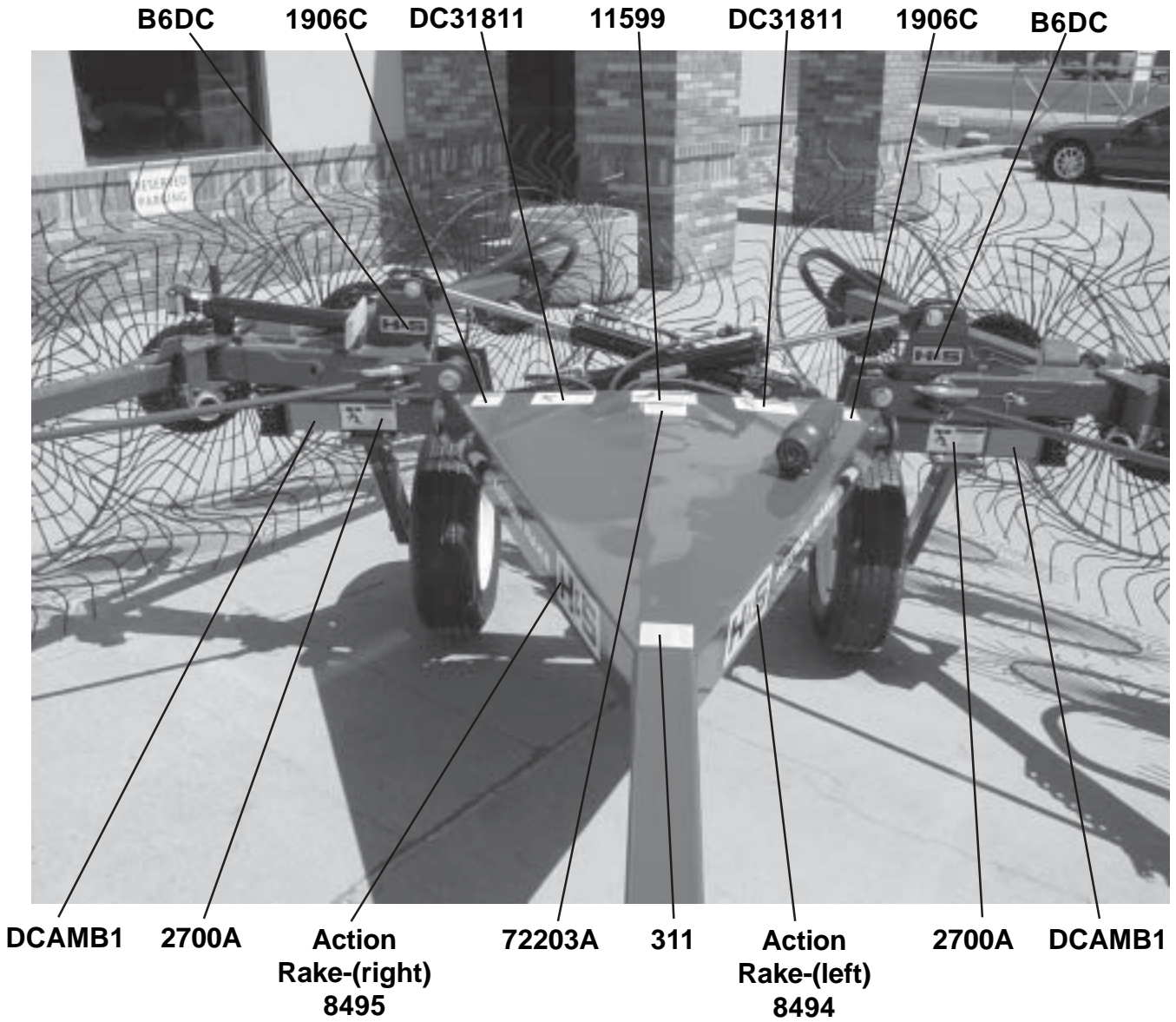

OLD PICTURES - TIRES ON WRONG SIDE OF SPINDLES



**2700B
1 Decal
on the
arm of
each side**

DECAL PLACEMENT



DCRED

8496

Model # AR8 - 8497
AR10 - 8501
AR12 - 8505

DCRED



82602

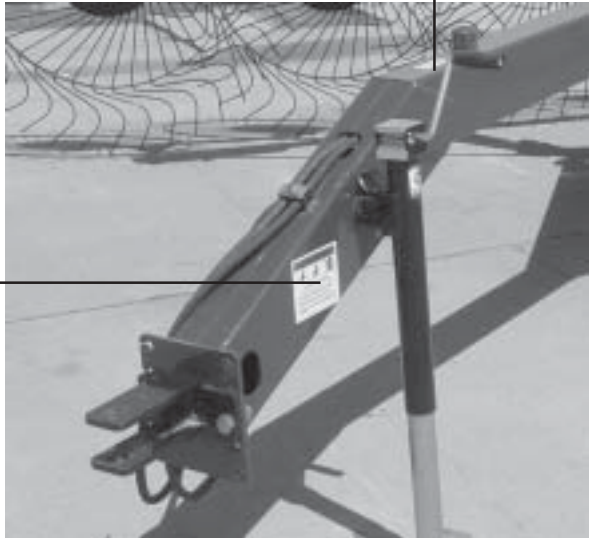

71188B

TROUBLESHOOTING

NOTE: This *Troubleshooting* Chapter presents problems, causes and suggested remedies beyond the extent of loose, worn or missing parts and it was developed with the understanding that the machine is in otherwise good operating condition.



WARNING:

MAKE SURE THAT THE TRACTOR IS SHUT OFF AND THE RAKE CAN NOT MOVE BEFORE SERVICING THE RAKE. MAINTENANCE AND REPAIR SERVICE WORK TO BE PERFORMED BY A QUALIFIED SERVICE PERSON ONLY.

PROBLEM	CAUSE	REMEDY
Rake Lifting Arms Will Not Lower	Hydraulic Transport Lock Valve Is In Closed Position	Rotate Transport Lock Valve To Open Position
	Hydraulic Coupler Hoses Not Coupled To Tractor Properly	Couple Hoses To Tractor
Rake Lifting Arms Will Not Raise	Hydraulic Coupler Not Coupled To Tractor Properly	Couple Hose To Tractor
	Tractor Hydraulics Do Not Have Sufficient Pressure	Tractor Should Have At Least 1500 PSI To Operate Rake
	Hydraulic Transport Lock Valve Is In Closed Position	Rotate Transport Lock Valve To Open Position

INSTRUCTIONS FOR ORDERING PARTS

All service parts should be ordered through your authorized H&S dealer. They will be able to give you faster service if you will provide them with the following

1. Model & Serial number is located on the left front of the main frame of your unit.
2. All reference to left or right apply to the machine as viewed from the rear.
3. Parts should not be ordered from illustration only. Please order by complete part number.
4. If your dealer has to order parts - give shipping instructions:

VIA truck - large pieces (please specify local truck lines)

VIA United Parcel Service (include full address)

H&S MFG. CO. INC.	
MARSHFIELD, WIS.	
MOD. NO.	<input type="text"/>
SER. NO.	<input type="text"/>
DESCR.	<input type="text"/>

PLEASE RECORD NUMBERS FOR YOUR UNIT FOR QUICK REFERENCE

ABOUT IMPROVEMENTS

H&S IS CONTINUALLY STRIVING TO IMPROVE IT'S PRODUCTS

We must therefore, reserve the right to make improvements or changes whenever it becomes practical to do so without incurring any obligation to make changes or additions to the equipment previously sold.

FIGURE 1

FRAME COMPONENTS

<u>ITEM</u>	<u>8 WHEEL</u>	<u>10 WHEEL</u>	<u>12 WHEEL</u>	<u>DESCRIPTION</u>
1	10WR7	"	"	RAKE ARM PIN (TWO OF THESE REQUIRED ON 8 WHEEL RAKE)
2	8ERWE01	10ERWE02	12ERWE11	FRAME WELDMENT
3	10ERWE06	"	"	10ER CLEVIS
4	YBHH24018	"	"	BOLT 3/4"-10 X 2 GR 8 YELLOW ZINC
5	YWLO24005	"	"	WASHER, LOCK, 3/4"
6	YNHX24006	"	"	HEX NUT 3/4"-10 GR. 8
7	G89	"	"	.250 x 28 STRAIGHT GREASE ZERK
8	YBHH08100	"	"	BOLT, 1/4" X 3/4" GR. 5
9	YNRL08005	"	"	HEX NUT, REVERSIBLE-SIDE LOCK, 1/2"-20
10	YWFL08005	"	"	FLAT WASHER
11	CAT18	"	"	WHEEL 15X5 ASM
12	CAT199	"	"	225-75 R15
13	10ERWE07	"	"	AXLE WELDMENT 60 IN WHEEL
14	CAT5	"	"	SEAL
15	CAT6	"	"	INNER CONE
16	CAT10	"	"	OUTER CONE
17	CAT14	"	"	WHEEL NUT 1/2"-20
18	CAT8	"	"	HUB WITH RACES
19	CAT7	"	"	INNER BEARING RACE
20	CAT9	"	"	OUTER BEARING RACE
21	CAT128A	"	"	STUD BOLT 1/2"-20 UNF X 1-7/8" GR 5
22	YPCT05015	"	"	COTTER PIN, 5/32" X 1-1/4"
23	YNSL24010	"	"	HEX NUT, SLOTTED, 3/4"-16
24	YWFL24005	"	"	WASHER, FLAT, 3/4" USS
*	10WR49	"	"	COMPLETE HUB
25	10WR47	"	12WR1	RAKE ARM SPRING
26	YBHH24042	"	"	3/4"-10 X 2-3/4" GR. 5 FULL THREAD
27	YNJM24010	"	"	HEX NUT, JAM, 3/4"-10
28	YWFL24005	"	"	FLAT WASHER
29	YBHH24014	"	"	BOLT, 3/4"-10 X 1-3/4" GR. 5
30	YBHH10085	"	"	5/16"-18 x 2-1/2" GR. 5
31	YNTL10005	"	"	NUT, 5/16" TOP LOCK
32	S522	"	"	MANUAL HOLDER
33	10ERWE01	"	12ERWE12	POLE
34	CAT46	"	"	HUB CAP
35	YBHH16055	"	"	BOLT, 1/2" X 1-3/4" GR 5
36	10ERWE08	"	"	AXLE WELDMENT LH 60 IN WHEEL
37	YWLO16005	"	"	WASHER, LOCK, 1/2"
38	YNHX16005	"	"	HEX NUT, 1/2"
39	BFR753A	"	"	JACK 2000# SIDE WIND
40	-	0240WE05	"	PIVOT ARM PIN
41	10ERWE05	"	"	SPRING HOLDER

**NOTE: " MEANS SAME AS PREVIOUS MODEL
 - MEANS NOT USED ON THIS MODEL**

FIGURE 2

RAKE BEAMS AND WHEELS

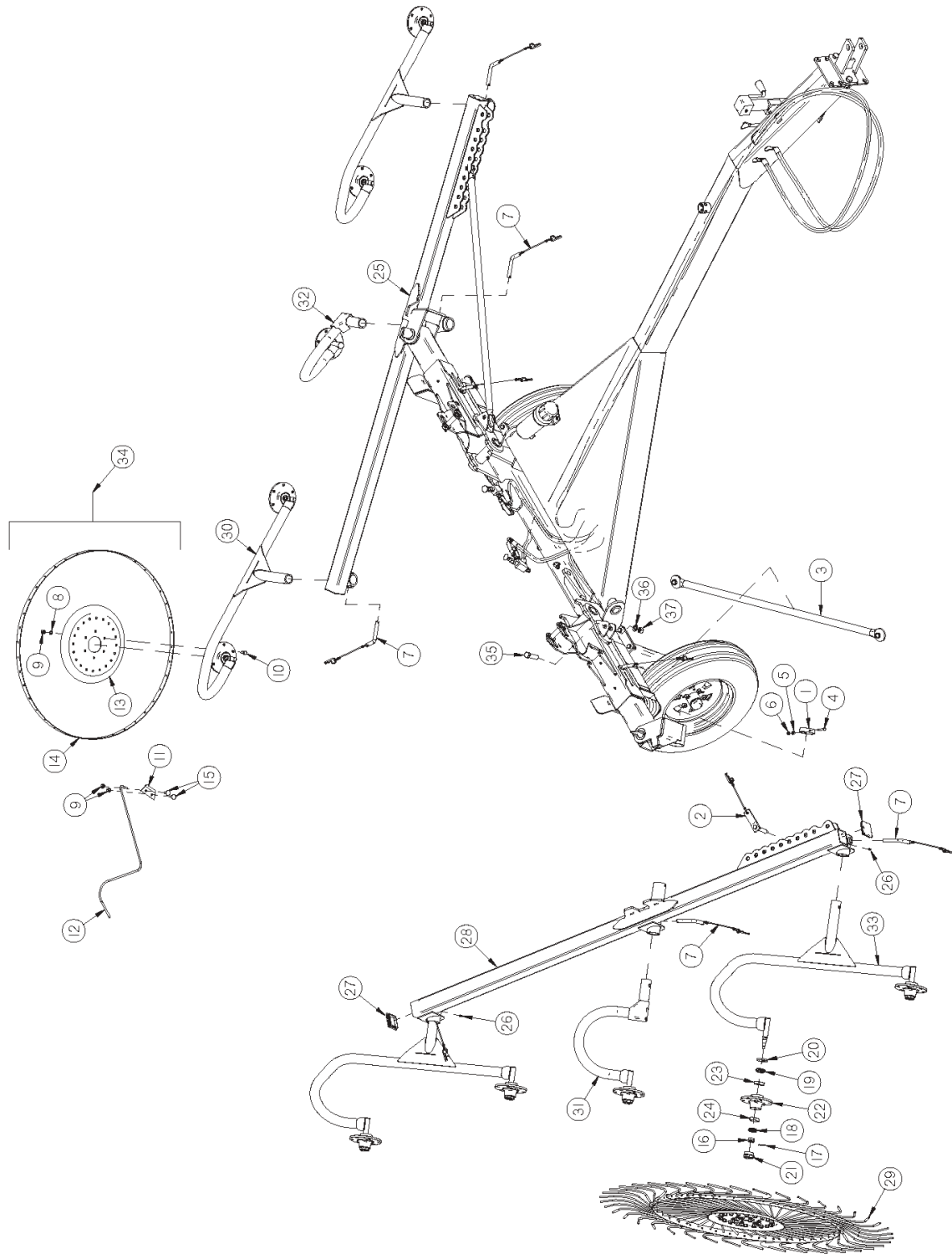

FIGURE 2

RAKE BEAMS AND WHEELS

<u>ITEM</u>	<u>8 WHEEL</u>	<u>10 WHEEL</u>	<u>12 WHEEL</u>	<u>DESCRIPTION</u>
1	10WR8	"	"	PIVOT THRUST WASHER
2	10ERAS20	"	"	WIDTH LINK PIN ASSEMBLY
3	8ERWE06	10ERWE13	"	BEAM ANGLE LINK
4	YBHH10110	"	"	BOLT, 5/16 X 3-1/2 GR 5
5	YWLO10005	"	"	WASHER, LOCK, 5/16
6	YNHX10005	"	"	HEX NUT
7	10ERAS08	"	"	CANE PIN ASSEMBLY
8	YWLO76015	"	"	WASHER, LOCK, M10
9	YNHX76015	"	"	HEX NUT, M10-1.5
10	YBHH76015	"	"	BOLT, M10-1.5 (25MM)
11	T178	"	"	TOOTH CLIP
12	FR73	"	"	60 IN WHEEL TOOTH
13	T179	"	"	RAKE WHEEL DISH
14	FR72	"	"	60 IN WHEEL BAND
15	YBCR76005	"	"	CARR. BOLT, 10MM X 25MM (T168)
16	T172	"	"	1.5 X 18MM CASTLE NUT
17	1088	"	"	RETAINING CLIP (REPLACES T169)
18	T170	"	"	OUTER CONE
19	T164	"	"	INNER CONE
20	T163	"	"	SEALING WASHER
21	T173	"	"	HUB CAP
22	1086	"	"	ITALIAN RAKE WHEEL HUB
23	T165	"	"	INNER RACE
24	T171	"	"	OUTER RACE
25	8ERWE05	10ERWE09	12ERWE10	LEFT RAKE BEAM
26	G89	"	"	.250 x 28 STRAIGHT GREASE ZERK
27	1075	"	"	TUBING CAP 3 X 3 SQ.
28	8ERWE04	10ERWE03	12ERWE09	RIGHT RAKE BEAM
29	FR70	"	"	60" RAKE WHEEL RH
30	12ERWE04	"	"	LEFT CANE WELDMENT
31	-	10ERWE11	-	CENTER CANE WELDMENT RH
32	-	10ERWE12	-	CENTER CANE WELDMENT LH
33	12ERWE08	"	"	RIGHT CANE WELDMENT
34	FR69	"	"	60" RAKE WHEEL LH

NOTE: " MEANS SAME AS PREVIOUS MODEL
 - MEANS NOT USED ON THIS MODEL

FIGURE 3

LIFT ARMS AND HYDRAULICS

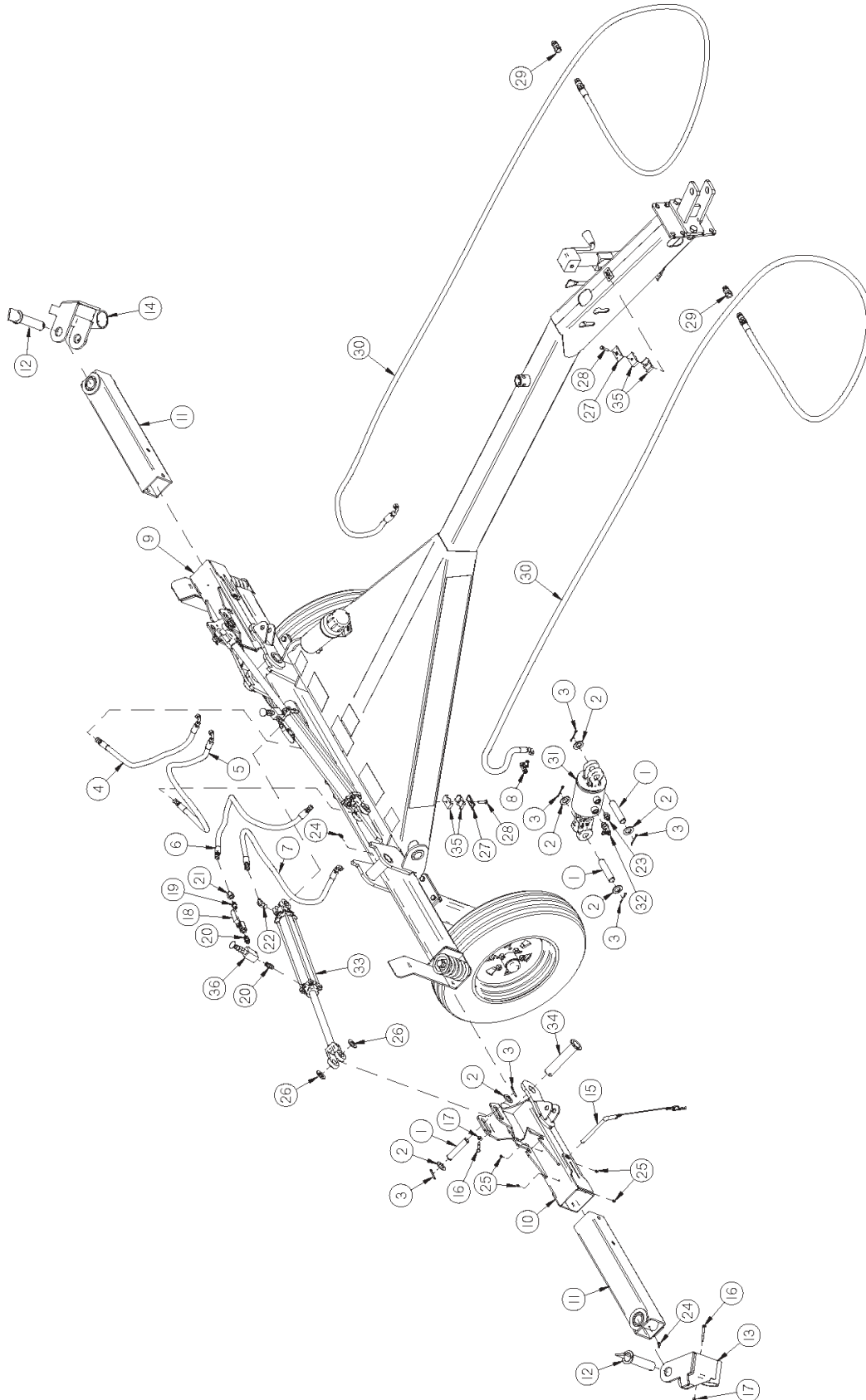

FIGURE 3

LIFT ARMS AND HYDRAULICS

<u>ITEM</u>	<u>8 WHEEL</u>	<u>10 WHEEL</u>	<u>12 WHEEL</u>	<u>DESCRIPTION</u>
1	LW55	"	"	CYLINDER PIN, LONG
2	16SV136	"	"	SPEED CONTROL WASHER
3	YPCT06020	"	"	COTTER PIN 3/16" X 2"
4	10ERMS02	"	"	HOSE, 90 DEG ENDS
5	10ERMS07	"	"	HOSE, 90 DEG ENDS
6	10ERMS03	"	"	HOSE, STRT ENDS
7	10ERMS08	"	"	HOSE, 90 DEGREE ENDS
8	8005	"	"	06 BULKHEAD TEE FITTING
9	-	10ERWE04	"	LEFT SLIDER HOUSING WELDMENT
10	-	12ERWE07	"	RIGHT SQUARE SLIDER HOUSING
11	-	10WR34	"	SLIDE ARM
*	8ERWE08	-	-	MAIN BEAM ARM LH
*	8ERWE07	-	-	MAIN BEAM ARM RH
12	10WR6	"	"	RAKE BEAM PIN
13	12ERWE06	"	"	12ER RIGHT INTERMEDIATE LINKAGE
14	12ERWE05	"	"	12ER LEFT INTERMEDIATE LINKAGE
15	10ERAS01	"	"	ARM SLIDER PIN ASSEMBLY
16	YBHH10085	"	"	5/16"-18 x 2-1/2" GR. 5
17	YNTL10005	"	"	NUT, 5/16" TOP LOCK
18	16SV338	"	"	3/8" BALL VALVE
19	CHM202	"	"	3/8" MALE NPT TO 06 MALE 90 ELBOW
20	16SV351	"	"	3/8" NIPPLE
21	1023	"	"	06-06 M/F ORIFICE, 0.047
22	CHM164	"	"	MALE ELBOW CTX ~ 6-6 CTX
23	CHM207	"	"	06 TO 3/4"-16 ORB STRT FITTING
24	RG21	"	"	1/4"-28 45° ZERK
25	G89	"	"	1/4" x 28 STRAIGHT GREASE ZERK
26	BFR33	"	"	WASHER
27	CHM277	"	"	3/8" COVER PLATE
28	YBHH10010	"	"	BOLT, 5/16" X 1" GR. 5
29	DWM205	"	"	MALE QUICK COUPLER 1/2"
30	10ERMS04	"	12ERMS01	HOSE, TRACTOR
31	1059	"	"	CYLINDER, ACTION REPHASE
32	1076	"	"	TEE, 1/2" ORB TO 3/8" JIC
33	23N111A	"	"	HYD. CYLINDER, 2" X 16"
34	10WR7	"	"	RAKE ARM PIN
35	CHM278	"	"	3/8" DOUBLE HOSE CUSHIONS
36	8735	"	"	SEQUENCE VALVE

**NOTE: " MEANS SAME AS PREVIOUS MODEL
 - MEANS NOT USED ON THIS MODEL
 * MEANS NOT SHOWN**

FIGURE 4

OPTIONAL KICKER WHEELS

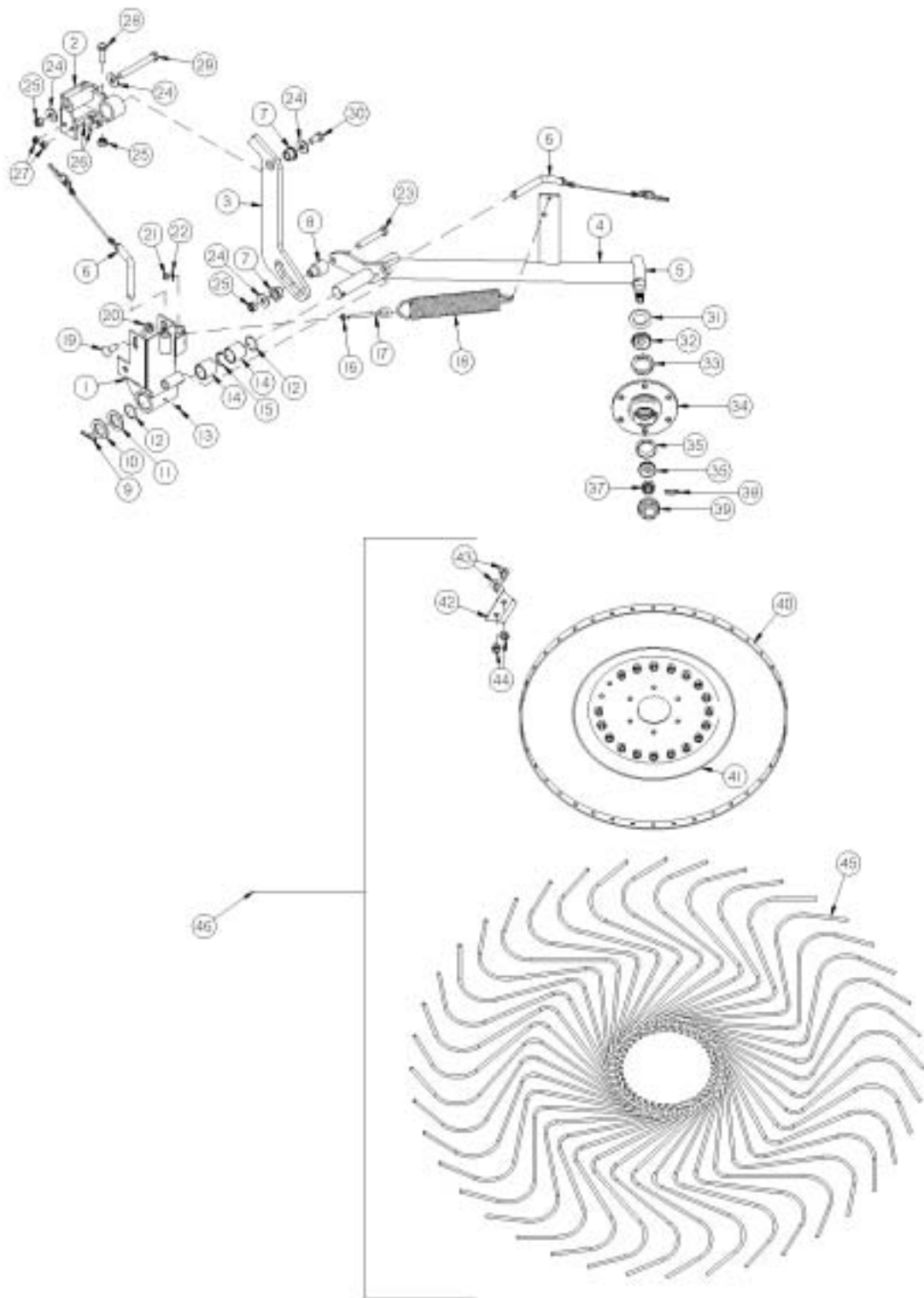

FIGURE 4

OPTIONAL KICKER WHEELS

<u>ITEM</u>	<u>8 WHEEL</u>	<u>10 WHEEL</u>	<u>12 WHEEL</u>	<u>DESCRIPTION</u>
1	-	0240WE04	"	KICKER MOUNT WELD
2	-	0240WE07	"	KICKER STOP WELDMENT
3	-	0240HF03	"	KICKER LEVER LINK FRAME PIVOT
4	-	0240WE03	"	KICKER ARM WELD
5	-	BFR36	"	RAKE WHEEL SPINDLE
6	-	10ERAS08	"	CANE PIN ASSEMBLY
7	-	8579	"	POLY PIVOT BEARING
8	-	0240TU04	"	KICKER PIVOT SPACER LOWER
9	-	YPEX10017	"	EXPANSION PIN, 5/16" X 2"
10	-	12X1818	"	WASHER
11	-	BFR221	"	POLY WASHER
12	-	S99	"	KICKER O RING
13	-	G89	"	1/4" X 28 GREASE ZERK
14	-	G16	"	BRONZE BUSHING 1-1/2" OD X 1-1/4" ID X 1.5"
15	-	BFR230	"	BEARING SPACER
16	-	YNHX10005	"	HEX NUT, 5/16"
17	-	YBTE10030	"	TURNT EYE BOLT, 5/16" X 3"
18	-	BFR110	"	SPRING
19	-	YBCR16015	"	CARR. BOLT, 1/2" X 1-1/4" GR. 5
20	-	YNSF16005	"	HEX NUT, SERRATED FLANGE, 1/2-13"
21	-	YNNY10005	"	HEX NUT, NYLON LOCKNUT, 5/16"-18
22	-	YWFL10005	"	WASHER, FLAT, 5/16" USS
23	-	YBHH16120	"	BOLT, 1/2" X 3-1/4" GR. 5
24	-	YWFL16005	"	WASHER, FLAT, 1/2" USS
25	-	YNRL16005	"	HEX NUT, REVERSIBLE-SIDE LOCK, 1/2"-13
26	-	YBHH12010	"	BOLT, 3/8" X 1" GR. 5
27	-	YNRL12005	"	HEX NUT, REVERSIBLE-SIDE LOCK, 3/8"-16
28	-	YBHH16030	"	BOLT, 1/2" X 1-1/2" GR. 5
29	-	YBHH16140	"	BOLT, 1/2" X 4-1/2" GR. 5
30	-	YBHH16010	"	BOLT, 1/2" X 1" GR. 5
31	-	T163	"	SEALING WASHER
32	-	T164	"	INNER CONE
33	-	T165	"	INNER RACE
34	-	1086	"	ITALIAN RAKE WHEEL HUB
35	-	T171	"	OUTER RACE
36	-	T170	"	OUTER CONE
37	-	T172	"	1-1/2" X 18MM CASTLE NUT
38	-	1088	"	RETAINING CLIP
39	-	T173	"	HUB CAP
40	-	T177A	"	RAKE WHEEL BAND
41	-	T179	"	RAKE WHEEL DISH
42	-	T178	"	TOOTH CLIP
43	-	YBCR76005	"	CARR. BOLT, 10MM X 25MM
44	-	YNHX76015	"	HEX NUT, M10-1.5
45	-	10WR42	"	RAKE WHEEL TOOTH
46	-	10WR17	"	LH RAKE WHEEL COMPLETE

**NOTE: " MEANS SAME AS PREVIOUS MODEL
 - MEANS NOT USED ON THIS MODEL**

FIGURE 5

HYDRAULIC CYLINDER

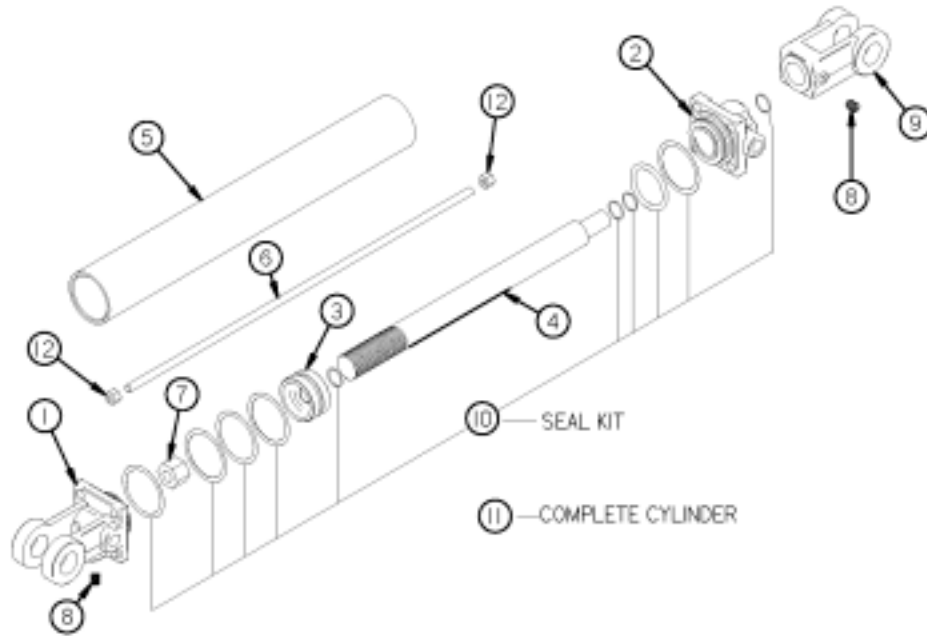

<u>ITEM</u>	<u>8 WHEEL</u>	<u>10 WHEEL</u>	<u>12 WHEEL</u>	<u>DESCRIPTION</u>
1	T181A	"	"	CLEVIS CAP
2	T182A	"	"	ROD CAP
3	T183	"	"	PISTON
4	23N145A	"	"	ROD
5	10WR45	"	"	CYLINDER TUBE
6	23N147	"	"	TIE ROD
7	23N148	"	"	PISTON NUT
8	23N149	"	"	PLUG
9	23N150A	"	"	ROD CLEVIS
10	T187	"	"	SEAL KIT
11	10WR11A	"	"	COMPLETE HYDRAULIC CYLINDER

Specifications

<u>Model</u>	<u>AR08</u>	<u>AR10</u>	<u>AR12</u>
Number of Wheels	8	10	12
Wheel Diameter	60"	60"	60"
Teeth per Wheel	40	40	40
Tooth Diameter – 60"	7.5mm	7.5mm	7.5mm
Rake Wheel Hubs	Tapered Brgs.	Tapered Brgs.	Tapered Brgs.
Transport Width	10'	10'8"	12'
Transport Length	17'	19'	21'6"
Transport Height in Transport Position	86"	101"	105"
Raking Width	15' – 19'	18' – 22'	20' – 24'
Windrow Width Adjustment	3' – 5'	4' – 6'	4' – 6'
Number of Raking Positions w/Transport Position	6	10	10
Ground Pressure Rake Wheel Adjustment	Adjustable Tension Spring	Adjustable Tension Spring	Adjustable Tension Spring
Action Cylinder – Raise/Lower	4½"	4½"	4½"
Wing Cylinders	2" x 16"	2" x 16"	2" x 16"
Jack	Standard	Standard	Standard
Weight	1,400#	1,670#	1,860#
Center Kicker Wheel	N/A	Optional	Optional

H&S MFG. CO.

products approved

for the

FEMA

SEAL OF QUALITY

