

- NOTES : 1.) FINISH - PAINT BLACK
 2.) PART TO BE SHOT PEENED TO ALMEN C-7 MINIMUM, IN INDICATED AREA
 3.) HARDNESS ROCKWELL C 42-26
 4.) MAT'L 3/4 X 2 5160 FLT

PART # 24648
 List Price \$162.64

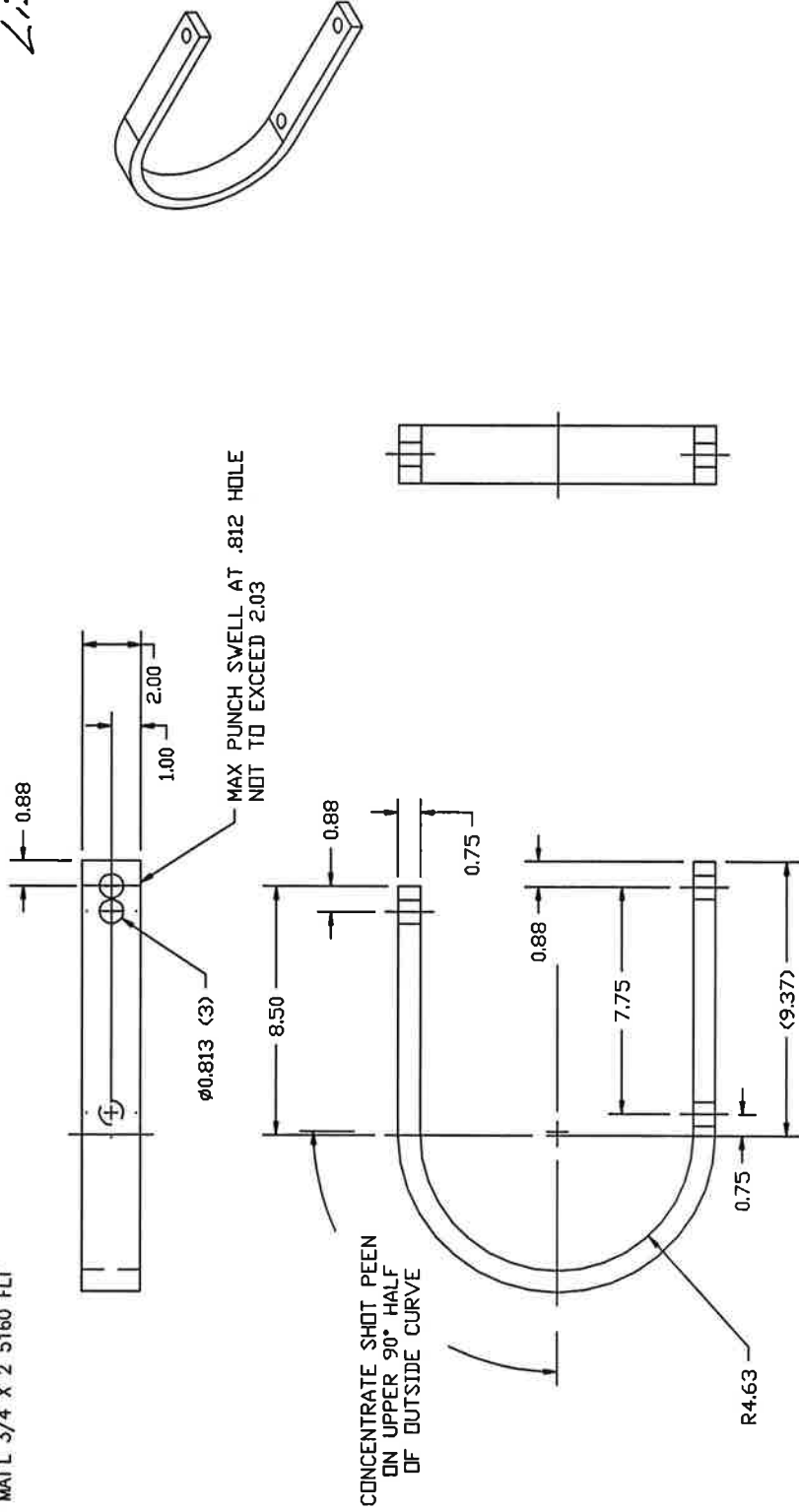

14) STD. MIL. TOL. UNLESS SPEC.	
PPP			
WIL-RICH LLC			
SPRING SHANK - FINISHING DISC			
TOLERANCE UNLESS SPECIFIED		DO NOT SCALE THIS DRAWING	
DECIMAL: X	±.06 [1.5]	REMOVE ALL SHARP EDGES	
XX	±.03 [0.8]	PREP	ALR 5-17-10
XXX	±.015 [0.38]	APVD	ALR
HOLE DIA:	-.005 +.015	SCALE	NONE
ANGLES:	±1.5° METRIC: []	ALR	28723
RELEASE TO MDT		DWG NO.	28723
REVISION	ITEM	CLS	-
EO	BY	DATE	LTR
026108	DAL	2/91	A

TSC NOTICE: WIL-RICH LLC claims proprietary rights to the information disclosed on this drawing. It is issued in confidence for engineering information only, and may not be reproduced or used to manufacture anything shown hereon without direct written permission from WIL-RICH LLC to the user.

- NOTES: 1) MAT'L - 1x2-1/2 S160 FLAT
 HARDNESS - ROCKWELL C42-46
 2) FINISH - PAINT BLACK.
 3) PART MUST BE SHOT PEENED TO
 ALUMEN C-7 MINIMUM IN THE
 AREA INDICATED

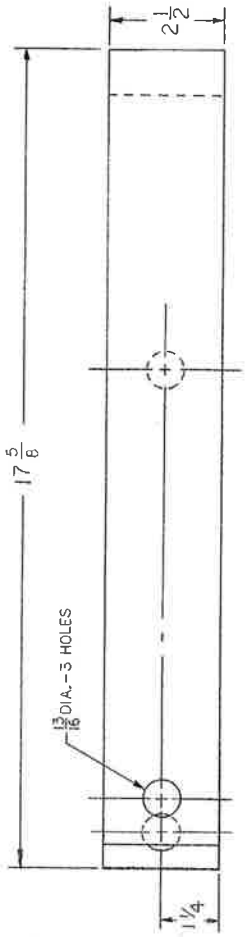

TOP VIEW

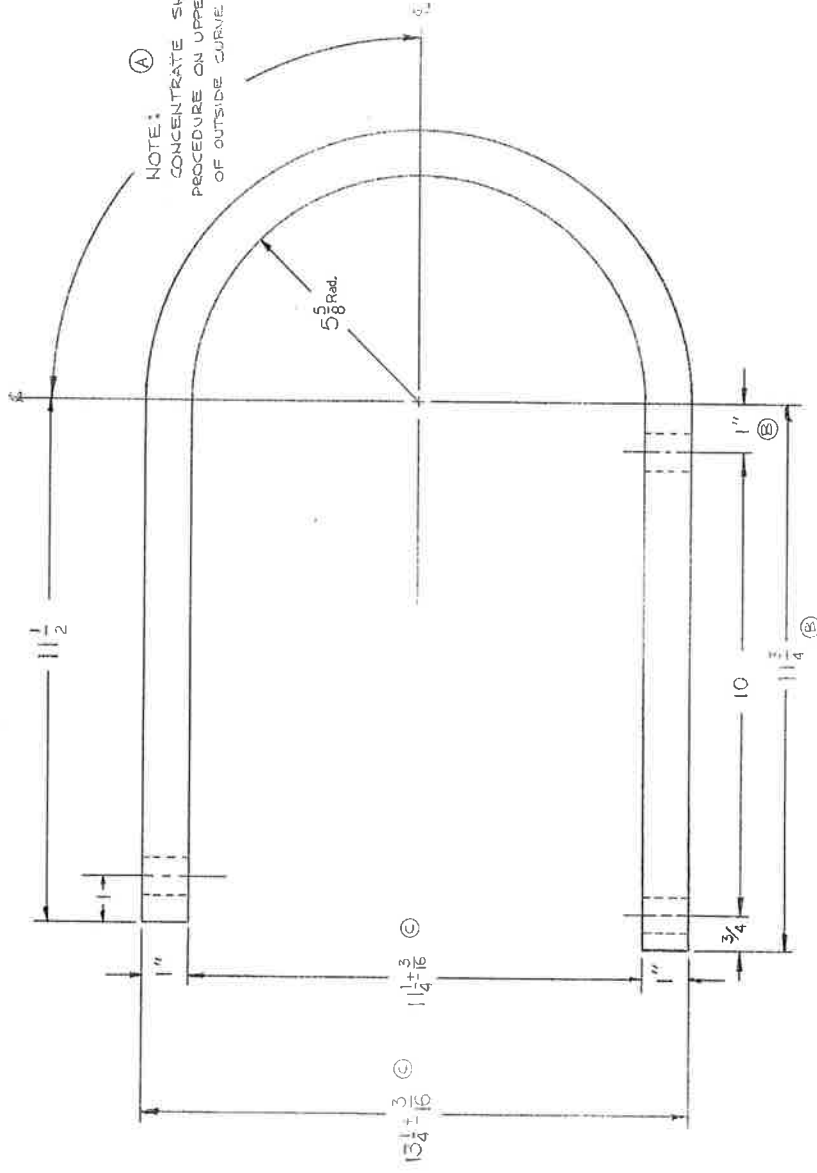

SIDE VIEW

PART # 25706
 List Price \$236.40

DRAWING NO. 41430

WIL-RICH THIS PART NUMBER P/N 25706
 HAS BEEN EQUIPMENT DIVISION SUPERSEDES PREVIOUSLY ASSIGNED
 MAT'L P/P

HUTCHINSON DIVISION
 LEAR SIEGLER, INC.
 CLAY CENTER, KANSAS 67432

PART NAME: SPRING SHANK ROLLING
 SCALE: 1/2" = 1"
 MATERIAL: C

DATE: 7/12/83
 DRAWN: BF 7/12/83
 CHECKED: BF 7/26/83
 APPROVED: BF 7/15/83

TOLERANCES UNLESS NOTED:
 DIMENSIONS ± .005 IN. UNLESS SHOWN OTHERWISE
 ANGLES ± 1° UNLESS SHOWN OTHERWISE
 FINISHES ± 1/32 IN. 0.75 RA

DRAWING NO. 41430

REV	DATE	BY	DESCRIPTION
E1	11/85	DRL	ADD NOTE 3
D	7/24/83	BF	WR RELEASE 05850
C	7/16/83	BF	± 1/16 TO ± 3/16
B	11/2 TO 11 3/4	BF	3/4 TO 1"
A	7/15/83	BF	ADDED NOTE
0	7/12/83	BF	REPLACED 40407
REV	DATE	BY	DESCRIPTION

This document contains proprietary information belonging to Lear Siegler, Inc. and such information may not be disclosed to others, reproduced, copied or used without written authority from an officer of Lear Siegler, Inc.